

Bend Tool

Description		Gkt1u Projector Mount 23 To 30Cm With Universal Mount			
UNLESS OTHERWISE SPECIFIED: DIMENSIONS ARE IN MILLIMETERS		Mod Date	17/03/2016	REVISION	Bend & Machine Number
SURFACE FINISH: Powder Coated		Drawn Date:	25/01/2007	A-007	
DRAWN	Jim Morley	Material			DWG NO.
Unicol Engineering Green Road Oxford OX3 8EU		Gauge			
		WEIGHT:	Kg	SCALE:1:5	DO NOT SCALE DRAWING
				SHEET 1 OF 3	

GKT1U

A4

1	2	3	4	5	6
BOM Table					
ITEM NO.	PART NUMBER	Description	Default/QTY.		
1	GKT1	Gkt1 Truss Projector Mount 23 To 30Cm	1		
2	GAPU	Universal Gyrolock Adapter Plate	1		

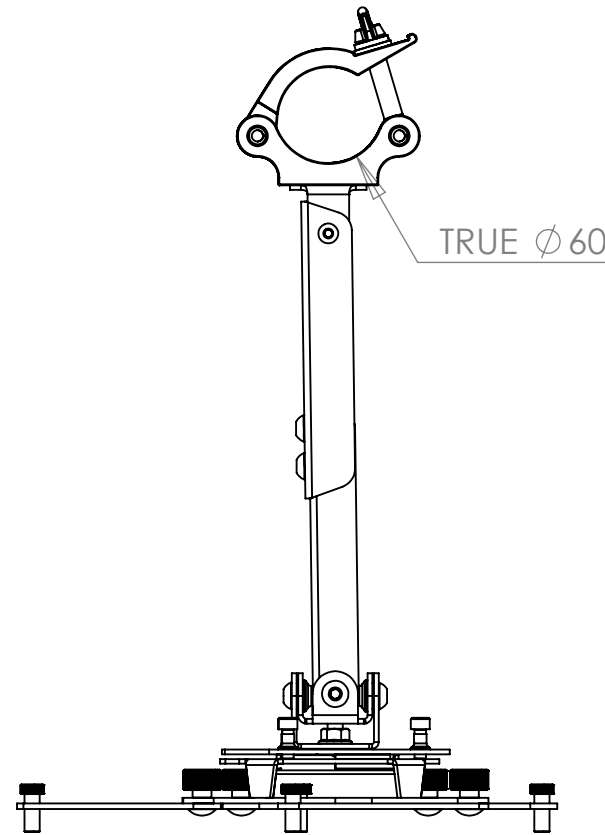
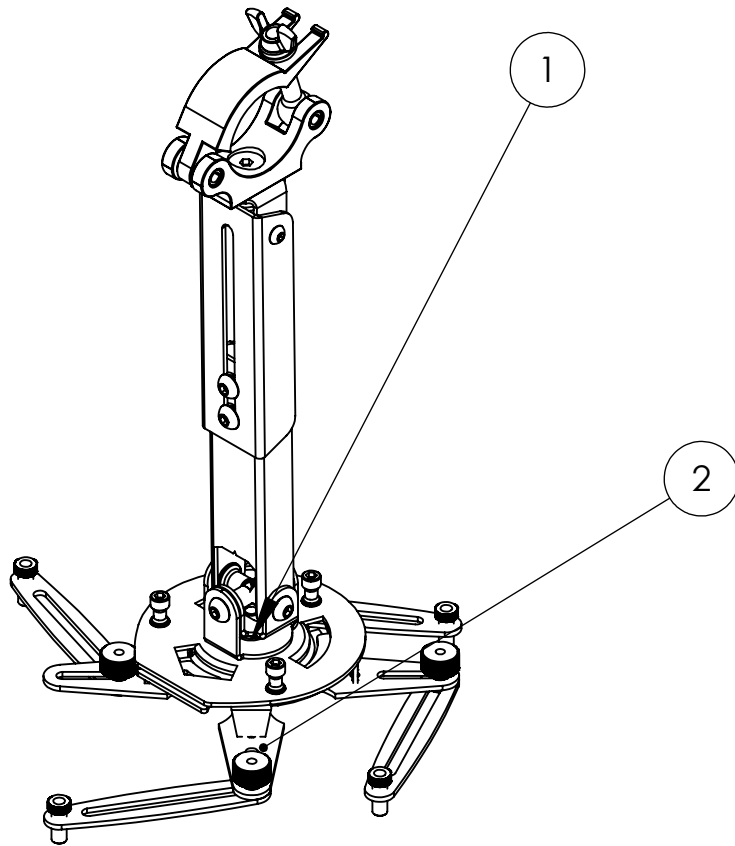

Description		Gkt1u Projector Mount 23 To 30Cm With Universal Mount			
UNLESS OTHERWISE SPECIFIED: DIMENSIONS ARE IN MILLIMETERS	Mod Date	17/03/2016	REVISION	Bend & Machine Number	
	Drawn Date:	25/01/2007	A-007		
SURFACE FINISH: Powder Coated	DRAWN <i>Jim Morley</i>		Material	DWG NO. GKT1U	
	Unicol Engineering Green Road Oxford OX3 8EU		Gauge		

Bend V Tool

A4

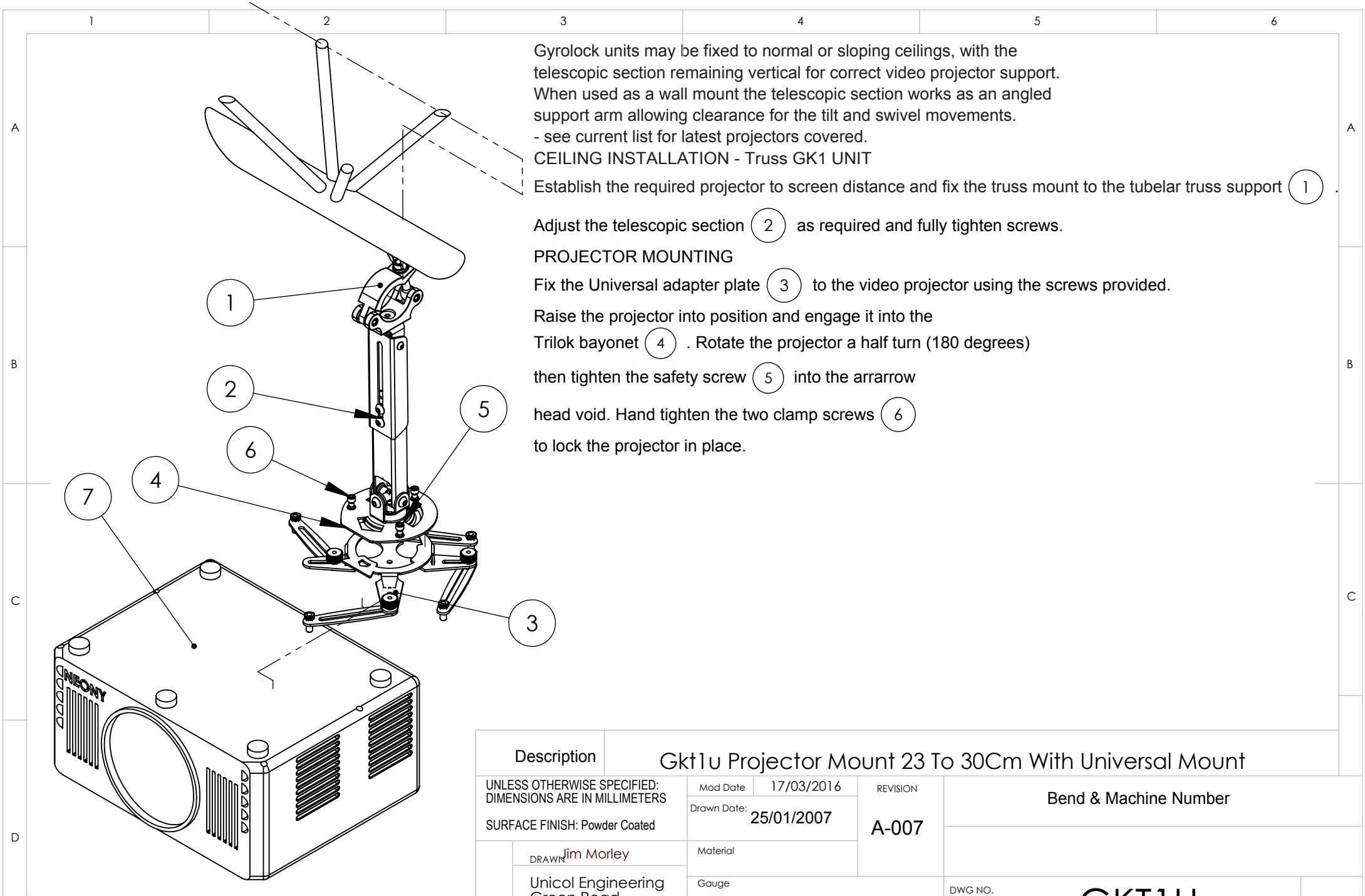

Gyrolock units may be fixed to normal or sloping ceilings, with the telescopic section remaining vertical for correct video projector support. When used as a wall mount the telescopic section works as an angled support arm allowing clearance for the tilt and swivel movements. - see current list for latest projectors covered.

CEILING INSTALLATION - Truss GK1 UNIT

Establish the required projector to screen distance and fix the truss mount to the tubular truss support (1)

Adjust the telescopic section (2) as required and fully tighten screws.

PROJECTOR MOUNTING

Fix the Universal adapter plate (3) to the video projector using the screws provided.

Raise the projector into position and engage it into the Trilok bayonet (4). Rotate the projector a half turn (180 degrees)

then tighten the safety screw (5) into the arrow head void. Hand tighten the two clamp screws (6)

to lock the projector in place.

Bend V Tool

Description		Gk1u Projector Mount 23 To 30Cm With Universal Mount		
UNLESS OTHERWISE SPECIFIED: DIMENSIONS ARE IN MILLIMETERS	Mod Date	17/03/2016	REVISION	Bend & Machine Number
	Drawn Date:	25/01/2007	A-007	
SURFACE FINISH: Powder Coated		Material		
DRAWN	Jim Morley	Gauge		DWG NO.
Unicol Engineering Green Road Oxford OX3 8EU				GKT1U
				A4