

visual engineering
LIGHTWARE

User's Manual



MMX8x4-HT420M
MMX8x4-HT400MC
MMX8x8-HDMI-4K-A

Multiport Matrix Switcher

Important Safety Instructions

Class I apparatus construction.

This equipment must be used with a mains power system with a protective earth connection. The third (earth) pin is a safety feature, do not bypass or disable it. The equipment should be operated only from the power source indicated on the product.

To disconnect the equipment safely from power, remove the power cord from the rear of the equipment, or from the power source. The MAINS plug is used as the disconnect device, the disconnect device shall remain readily operable.

There are no user-serviceable parts inside of the unit. Removal of the cover will expose dangerous voltages. To avoid personal injury, do not remove the cover. Do not operate the unit without the cover installed.

The appliance must be safely connected to multimedia systems. Follow instructions described in this manual.

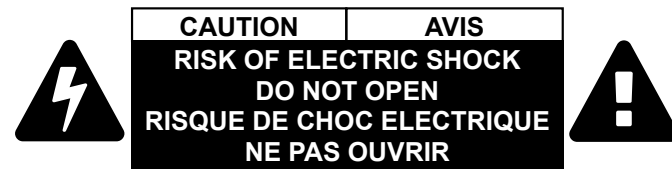

Ventilation

For the correct ventilation and to avoid overheating ensure enough free space around the appliance. Do not cover the appliance, let the ventilation holes free and never block or bypass the ventilators (if any).

WARNING

To prevent injury, the apparatus is recommended to securely attach to the floor/wall or mount in accordance with the installation instructions. The apparatus shall not be exposed to dripping or splashing and that no objects filled with liquids, such as vases, shall be placed on the apparatus. No naked flame sources, such as lighted candles, should be placed on the apparatus.

Waste Electrical & Electronic Equipment WEEE

This marking shown on the product or its literature, indicates that it should not be disposed with other household wastes at the end of its working life. To prevent possible harm to the environment or human health from uncontrolled waste disposal, please separate this from other types of wastes and recycle it responsibly to promote the sustainable reuse of material resources. Household users should contact either the retailer where they purchased this product, or their local government office, for details of where and how they can take this item for environmentally safe recycling. Business users should contact their supplier and check the terms and conditions of the purchase contract. This product should not be mixed with other commercial wastes for disposal.



Common Safety Symbols

Symbol	Description
	Alternating current
	Protective conductor terminal
	Caution, possibility of electric shock
	Caution

Symbol Legend

The following symbols and markings are used in the document:

WARNING! Safety-related information which is highly recommended to read and keep in every case!

ATTENTION! Useful information to perform a successful procedure; it is recommended to read.

INFO: A notice which may contain additional information. Procedure can be successful without reading it.

DEFINITION: The short description of a feature or a function.

TIPS AND TRICKS: Ideas which you may have not known yet but can be useful.

Navigation Buttons

 Go back to the previous page. If you clicked on a link previously, you can go back to the source page by clicking the button.

 Navigate to the Table of Contents.

 Step back one page.

 Step forward to the next page.

Document Information

All presented functions refer to the indicated products. The descriptions have been made during testing these functions in accordance with the indicated Hardware/Firmware/Software environment:

Item	Version
Lightware Device Controller (LDC) software	1.25.0b1
Lightware Device Updater Software	1.5.3.b4
Controller firmware	1.1.0.b10
Hardware	1.0

Document revision: **1.4**

Release date: 26.02.2019

Editor: Judit Barsony

About Printing

Lightware Visual Engineering supports green technologies and eco-friendly mentality. Thus, this document is made for digital usage primarily. If you need to print out few pages for any reason, follow the recommended printing settings:

- Page size: A4
- Output size: Fit to page or Match page size
- Orientation: Landscape

TIPS AND TRICKS: Thanks to the size of the original page, the border around the content (grey on the second picture below) makes possible to organize the pages better. After punching the printed pages, they can be placed easily into a ring folder.

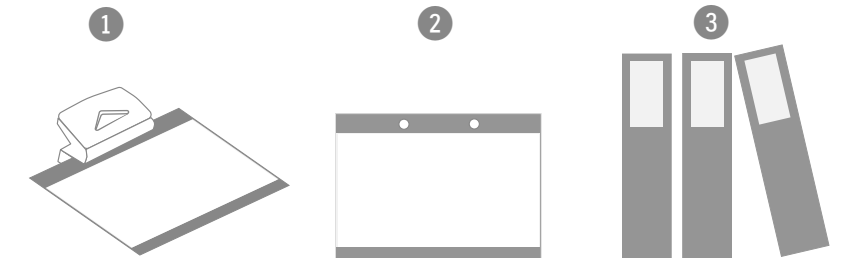

Table of Contents

1. INTRODUCTION	7	3.8. CONTROL FEATURES	24	5.7. AUDIO TAB	46
1.1. DESCRIPTION.....	7	3.8.1. Ethernet Interface	24	5.7.1. Panorama or Balance Settings	46
1.2. COMPATIBLE DEVICES	7	3.8.2. Infra Interface	26	5.7.2. Gain Settings	46
1.3. BOX CONTENTS	8	3.8.3. Serial Interface.....	27	5.7.3. Equalization (EQ) Settings	46
1.4. MODEL COMPARISON	8	3.8.4. GPIO Interface	28	5.7.4. Signal Indicator Chart.....	47
1.5. FEATURES OF THE DEVICE.....	9	3.8.5. Relay Interface.....	29	5.7.5. Digital Audio Selector Menu	47
1.6. TYPICAL APPLICATION	10	3.8.6. USB Control Interface.....	29	5.7.6. Scenes.....	47
2. INSTALLATION	11	4. OPERATION	30	5.7.7. Microphone Input Channel.....	48
2.1. MOUNTING OPTIONS -STANDARD RACK INSTALLATION.....	11	4.1. POWERING ON	30	5.7.8. Legend of Microphone Input Channel.....	48
2.2. CONNECTING STEPS.....	12	4.2. STATUS LEDs.....	30	5.7.9. Advanced Analog Input Channel	50
2.3. INSTALLATION GUIDE FOR CONNECTING A MICROPHONE.....	13	4.3. FRONT PANEL LCD MENU OPERATIONS.....	30	5.7.10. Embedded or Analog Input Channel	50
3. PRODUCT OVERVIEW	14	4.3.1. System Settings Menu	31	5.7.11. Legend of Embedded or Advanced Input Channel.....	50
3.1. FRONT VIEW	14	4.3.2. Ports Menu	31	5.7.12. Advanced Analog Output Channel	51
3.2. REAR VIEW	15	4.3.3. EDID Menu	32	5.7.13. Legend of Advanced Analog Output Channel.....	51
3.3. ELECTRICAL CONNECTIONS	16	4.3.4. Health Menu.....	32	5.8. PRESETS TAB	52
3.3.1. HDMI Input and Output Ports	16	4.3.5. Crosspoint Menu	33	5.9. EDID MENU	53
3.3.2. Analog Stereo Audio.....	16	4.4. FRONT PANEL BUTTON OPERATIONS.....	33	5.9.1. Sources and Destinations.....	53
3.3.3. Microphone IN	16	4.4.1. Control Lock.....	33	5.9.2. EDID Operations.....	53
3.3.4. RS-232 Connector.....	16	4.4.2. Take / Autotake Modes.....	33	5.9.3. EDID Summary Window	54
3.3.5. Infra/ Serial TTL Connector	16	4.4.3. View Crosspoint State.....	33	5.9.4. Editing an EDID	54
3.3.6. IR Connector	16	4.4.4. Switching Operations	34	5.9.5. Creating an EDID.....	55
3.3.7. Control Ethernet Port.....	17	4.4.5. Output Lock.....	34	5.10. CONTROL MENU	55
3.3.8. Ethernet Link to TPS Input/Output Ports	17	4.4.6. Control Lock.....	35	5.10.1. RS-232 Tab.....	55
3.3.9. TPS Input/Output Ports.....	17	4.4.7. Save or Load a Preset	35	5.10.2. Ethernet.....	56
3.3.10. GPIO - General Purpose Input/Output Ports.....	17	4.5. FRONT PANEL OPERATIONS – QUICK SUMMARY.....	36	5.10.3. Infra Tab	56
3.3.11. USB Connector	17	4.5.1. Take Mode	36	5.10.4. GPIO Tab	57
3.3.12. Relay Connector	17	4.5.2. Autotake Mode	36	5.10.5. Relay Tab.....	57
3.4. HDMI AND TPS MATRIX CONCEPT	18	5. SOFTWARE CONTROL – LIGHTWARE DEVICE CONTROLLER ...	37	5.11. EVENT MANAGER	58
3.5. TPS INTERFACE	18	5.1. INSTALL AND UPGRADE	37	5.11.1. The Event Editor.....	58
3.5.1. TPS Working Modes	18	5.2. RUNNING THE LDC	37	5.11.2. Create or Modify an Event.....	59
3.5.2. Power over Ethernet (PoE)	19	5.3. DEVICE DISCOVERY WINDOW	38	5.11.3. Special Tools and Accessories.....	59
3.6. VIDEO INTERFACE	20	5.4. CROSSPOINT MENU	39	5.11.4. Clear One or More Event(s).....	60
3.6.1. Port Diagram of MMX8x4-HT400MC	20	5.4.1. Crosspoint Operations	40	5.11.5. Export and Import Events	60
3.6.2. Port Diagram of MMX8x4-HT420M	20	5.5. VIDEO TAB	40	5.12. SETTINGS MENU	60
3.6.3. Port Diagram of MMX8x8-HDMI-4K-A.....	20	5.5.1. TPS Input Port Properties	40	5.12.1. Status	60
3.6.4. The Autoselect Feature.....	21	5.5.2. HDMI Input Port Properties	41	5.12.2. Network Tab.....	61
3.7. AUDIO INTERFACE	21	5.5.3. HDMI and TPS Output Port Properties.....	43	5.12.3. Backup	61
3.7.1. MMX8x4-HT400MC.....	21	5.6. DIAGNOSTIC TOOLS	44	5.12.4. System	61
3.7.2. MMX8x4-HT420M	22	5.6.1. Cable Diagnostics.....	44		
3.7.3. MMX8x8-HDMI-4K-A	22	5.6.2. Frame Detector	45		
3.7.4. General Audio Settings from Inputs to Outputs	22	5.6.3. Test Pattern Generator - No Sync Screen	45		

5.13. CONFIGURATION CLONING (BACKUP TAB)	61	6.5. GPIO SETTINGS	68	7.5.6. Unlock an Input Port.....	75
5.13.1. Cloning Steps in a Nutshell.....	61	6.5.1. Query GPIO State.....	68	7.5.7. Lock an Output Port.....	75
5.13.2. Save the Settings of the Device (Backup).....	62	6.5.2. Set GPIO State.....	68	7.5.8. Unlock an Output Port.....	75
5.13.3. Upload the Settings to a Device (Restore).....	62	6.6. RELAY SETTINGS	69	7.5.9. HDCP Setting (Input Port).....	75
5.13.4. Create and Restore Backups from the Device Memory.....	62	6.6.1. Query Relay Connection State.....	69	7.5.10. HDCP Setting (Output Port).....	75
5.14. ADVANCED VIEW	63	6.6.2. Set Relay Connection State.....	69	7.5.11. Query the Status of Source Port.....	76
6. LW2 PROGRAMMERS' REFERENCE	64	6.7. LW2 COMMANDS – QUICK SUMMARY	69	7.5.12. Query the Status of Destination Port.....	77
6.1. LW2 PROTOCOL DESCRIPTION	64	7. LW3 PROGRAMMERS' REFERENCE	70	7.5.13. Query the Video Autoselect Settings.....	77
6.2. GENERAL LW2 COMMANDS	64	7.1. OVERVIEW	70	7.5.14. Change the Autoselect Mode.....	77
6.2.1. View Product Type.....	64	7.2. PROTOCOL RULES	70	7.5.15. Query the Input Port Priority.....	78
6.2.2. View Serial Number.....	64	7.2.1. LW3 Tree Structure and Command Structure (examples).....	70	7.5.16. Changing the Input Port Priority.....	78
6.2.3. Query Device Label.....	65	7.2.2. General Rules.....	70	7.5.17. TPS Mode Settings on TPS Ports.....	78
6.2.4. Query Control Protocol.....	65	7.2.3. Command Types.....	71	7.5.18. Sending CEC Commands.....	79
6.2.5. View Firmware Version of the CPU.....	65	7.2.4. Prefix Summary.....	71	7.5.19. PoE Enable.....	80
6.2.6. Connection Test.....	65	7.2.5. Error Messages.....	71	7.5.20. Signal Type Settings (Output Ports).....	80
6.2.7. Compile Time.....	65	7.2.6. Escaping.....	71	7.5.21. Test Pattern.....	80
6.2.8. View Installed Board(s).....	65	7.2.7. Signature.....	72	7.6. EDID MANAGEMENT	81
6.2.9. View Firmware for all Controllers'.....	65	7.2.8. Subscription.....	72	7.6.1. Query the Emulated EDIDs.....	81
6.2.10. Restart the Matrix Router.....	65	7.2.9. Notifications about the Changes of the Properties.....	72	7.6.2. Set the Emulated EDID.....	81
6.2.11. Query Health Status.....	66	7.2.10. Legend for the Control Commands.....	72	7.6.3. Copy an EDID into Another Slot.....	81
6.2.12. Restore Factory Default Settings.....	66	7.3. SYSTEM COMMANDS	73	7.7. AUX ANALOG AUDIO I/O PORT SETTINGS	82
6.3. PORT AND CROSSPOINT SETTINGS	66	7.3.1. Query the Product Name.....	73	7.7.1. Audio Mode Setting.....	82
6.3.1. Switch One Input to One Output.....	66	7.3.2. Query the Device Label.....	73	7.7.2. AUX Analog Audio Input Settings.....	82
6.3.2. Switch One Input to All Output.....	66	7.3.3. Set the Device Label.....	73	7.7.3. AUX Analog Audio Output Settings.....	82
6.3.3. Mute Specified Output.....	66	7.3.4. Query the Serial Number.....	73	7.8. ADVANCED AUDIO SETTINGS	83
6.3.4. Unmute Specified Output.....	66	7.3.5. Setting the Rotary Direction of the Jog Dial Knob.....	73	7.8.1. Microphone Input Settings.....	83
6.3.5. Lock the Output.....	66	7.3.6. Control Lock.....	73	7.8.2. Advanced Analog Audio Input.....	85
6.3.6. Unlock the Output.....	66	7.3.7. Identify the Device.....	73	7.8.3. Embedded Audio Input Settings.....	86
6.3.7. View Connection State on the Output.....	67	7.3.8. Resetting the Matrix.....	73	7.8.4. Advanced Analog Audio Output.....	88
6.3.8. View Crosspoint Size.....	67	7.3.9. Restore the Factory Default Settings.....	73	7.8.5. Audio Presets.....	89
6.3.9. Batch Switch Outputs.....	67	7.4. SWITCHING AND CROSSPOINT SETTINGS	74	7.8.6. Audio Scenes.....	90
6.4. NETWORK CONFIGURATION	67	7.4.1. Query the Video Crosspoint State.....	74	7.9. SERIAL PORT SETTINGS	91
6.4.1. Query the Current IP Status.....	67	7.4.2. Switching an Input to an Output.....	74	7.9.1. Protocol Setting.....	91
6.4.2. Query the IP Address.....	67	7.4.3. Switching an Input to All Outputs.....	74	7.9.2. BAUD Rate Setting.....	91
6.4.3. Set the IP Address.....	68	7.5. VIDEO PORT SETTINGS	74	7.9.3. Operation Mode Setting.....	91
6.4.4. Query the Subnet Mask.....	68	7.5.1. Mute an Input Port.....	74	7.9.4. Command Injection Mode.....	91
6.4.5. Set the Subnet Mask.....	68	7.5.2. Unmute an Input Port.....	74	7.9.5. Query the RS-232 Command Injection Port Number.....	91
6.4.6. Query the Gateway Address.....	68	7.5.3. Mute an Output Port.....	74	7.10. IR PORT SETTINGS	92
6.4.7. Set the Gateway Address.....	68	7.5.4. Unmute an Output Port.....	74	7.10.1. Enable the IR Port.....	92
6.4.8. Apply Network Settings.....	68	7.5.5. Lock an Input Port.....	75	7.10.2. Query the IR Command Injection Port Number.....	92

7.11. RELAY PORT SETTINGS	92	9. TROUBLESHOOTING	108
7.11.1. Set Relay Connection Status	92	9.1. USE CASE STUDIES	108
7.12. GPIO PORT SETTINGS	92	9.2. HOW TO SPEED UP THE TROUBLESHOOTING PROCESS?	110
7.12.1. Set the Direction of a GPIO Pin.....	92	10. TECHNOLOGIES	111
7.12.2. Set the Output Level of a GPIO Pin.....	92	10.1. EDID MANAGEMENT	111
7.12.3. Toggle the Level of a GPIO Pin	92	10.1.1. Understanding the EDID.....	111
7.13. NETWORK CONFIGURATION	93	10.1.2. Advanced EDID Management.....	111
7.13.1. Query the Current IP Address	93	10.2. HDCP MANAGEMENT	112
7.13.2. Query the Current DHCP Status.....	93	10.2.1. Protected and Unprotected Content	112
7.13.3. Set a Dynamic IP Address.....	93	10.2.2. Disable Unnecessary Encryption.....	112
7.13.4. Set a Static IP Address	93	10.3. PIXEL ACCURATE RECLOCKING	113
7.13.5. Change the Subnet Mask (Static)	93	11. APPENDIX	114
7.13.6. Change the Gateway Address (Static).....	93	11.1. SPECIFICATION	114
7.13.7. Apply Network Settings.....	93	11.2. MECHANICAL DRAWINGS	116
7.14. SENDING MESSAGE VIA THE COMMUNICATION PORTS	94	11.3. MAXIMUM EXTENSION DISTANCES	116
7.14.1. Sending Message via TCP Port	94	11.4. FACTORY DEFAULT SETTINGS	117
7.14.2. UDP Message Sending via Ethernet.....	94	11.5. CONTENT OF BACKUP FILE	118
7.14.3. Message Sending via RS-232 Serial Port.....	95	11.6. FLOWCHART OF AUTOSELECT MODES	118
7.14.4. Using Hexadecimal Codes.....	95	11.7. PORT NUMBERING	119
7.14.5. Sending Pronto Hex Codes in Little-endian Format via IR Port. 96		11.7.1. MMX8x4-HT400MC.....	119
7.14.6. Sending Pronto Hex Codes in Big-endian Format via IR Port.... 96		11.7.2. MMX8x8-HDMI-4K-A	119
7.15. SYSTEM MONITORING COMMANDS	96	11.7.3. MMX8x4-HT420M.....	120
7.15.1. Query Video Signal Presence	96	11.8. CONDITIONS IN THE WIZARD TAB OF THE EVENT MANAGER	121
7.15.2. Query Connected Device (or Cable)	96	11.9. ACTIONS IN THE WIZARD TAB OF THE EVENT MANAGER	121
7.15.3. Query Embedded Audio	96	11.10. FACTORY EDID LIST	123
7.15.4. Hotplug Detect.....	97	11.11. AUDIO CABLE WIRING GUIDE	124
7.15.5. Query Audio Indicators.....	97	11.12. FURTHER INFORMATION	125
7.15.6. Remote	97		
7.16. LW3 QUICK SUMMARY	98		
8. FIRMWARE UPGRADE	103		
8.1. ABOUT THE FIRMWARE PACKAGE (LFP FILE)	103		
8.2. SHORT INSTRUCTIONS	103		
8.3. INSTALL AND UPGRADE	103		
8.4. DETAILED INSTRUCTIONS	104		
8.4.1. Establish the Connection	104		
8.4.2. Start the LDU and Follow the Instructions	104		
8.5. KEEPING THE CONFIGURATION SETTINGS	107		

1

Introduction

Thank you for choosing Lightware's MMX8x4-HT series device. In the first chapter we would like to introduce the device highlighting the most important features in the below listed sections:

- ▶ DESCRIPTION
- ▶ COMPATIBLE DEVICES
- ▶ BOX CONTENTS
- ▶ MODEL COMPARISON
- ▶ FEATURES OF THE DEVICE
- ▶ TYPICAL APPLICATION

1.1. Description

MMX8x4-series is a standalone matrix switcher specifically designed for collaboration room environments. It has eight video inputs and -depending on the model- four or eight video outputs. 4K / UHD (30Hz RGB 4:4:4, 60Hz YCbCr 4:2:0), 3D capabilities and HDCP are fully supported.

In MMX8x4-HT400MC and MMX8x4-HT420M models the special Audio Input Block includes input ports for microphone and line-in. The built-in sound mixer DSP allows for free mixing of the audio signals from the de-embedded HDMI, the microphone or the line-in. The built-in sound mixer DSP allows for free mixing of the audio signals from the de-embedded HDMI, the microphone or the line-in. The MIC port can also supply phantom power to the connected microphone. Voice Activated Presenter Focus allows the volume of the voice of the speaker to become automatically focused, and the volume of the rest of the sounds to be lowered, as soon as the presenter starts speaking. The built-in DSP provides audio mixer services including fader, equalizer, mute, balance and gain.

MMX8x8-HDMI-4K-A has six balanced, 5-pole Phoenix audio inputs or outputs for embedding or de-embedding purposes.

The unit can be controlled via RS-232, Ethernet or USB ports, but it also offers RS-232, Serial and IR command injection capabilities allowing to send any control command directly to end points.

About the Serial Number

Lightware devices contain a label indicating the unique serial number of the product. The structure is the following:

Year of the manufacturing (3-9, A-Y):
7=2017, 8=2018, 9=2019, A=2020, etc...

7A000941 — 6-digit running sequence number

Month of the manufacturing (1-9, A-C):
1=January, 2=February, ..., C=December

Model Denomination

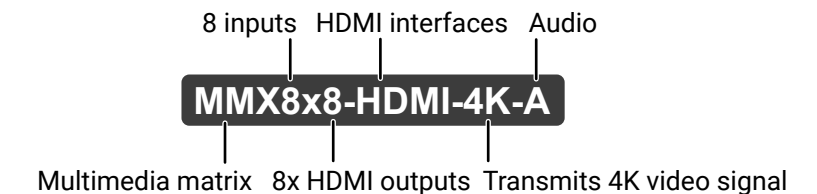
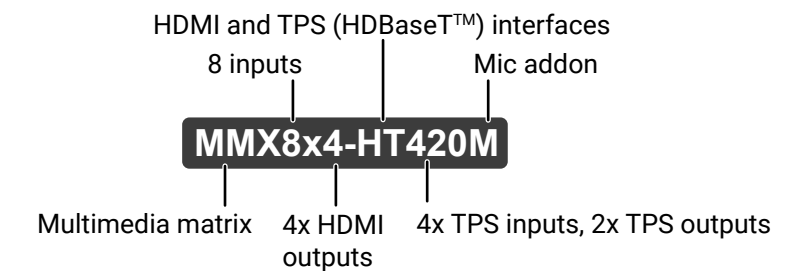
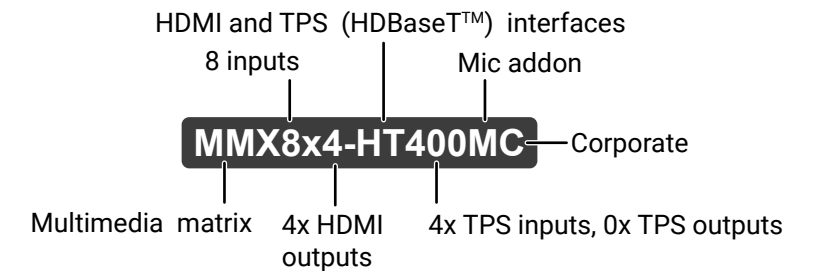

1.2. Compatible Devices

The matrix switchers are compatible with other Lightware TPS devices, matrix boards third-party HDBaseT™ extenders, displays, but not compatible with the phased out TPS-90 extenders.



WARNING! The remote power feature of TPS-95 extenders is not PoE-compatible. Thus, TPS-95 series cannot be powered remotely by the MMX8x4 matrix switchers (but the video signal is transmitted to/from the extenders). If an RX95 or TX95 is connected to the matrix, make sure that the remote power jumper of the extender is removed or set to 'Remote power disabled' position.

1.3. Box Contents

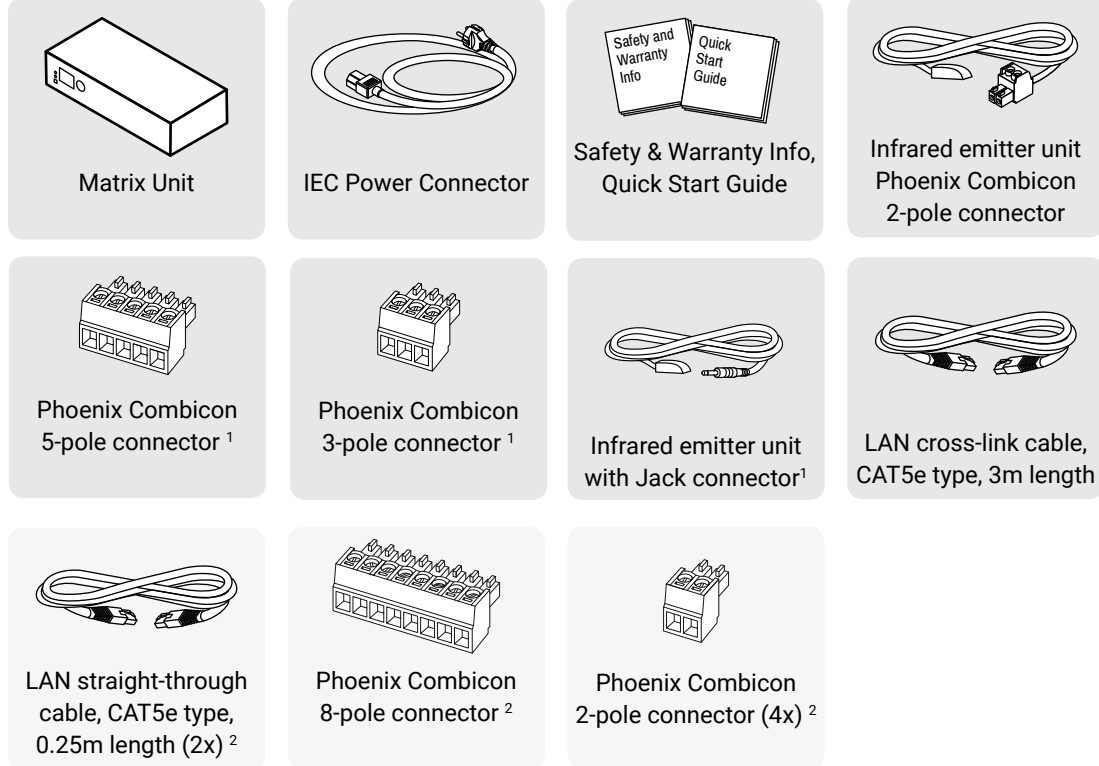

¹ Quantity of the items depends on the model.

² Only for the MMX8x4-HT420M model.

1.4. Model Comparison

Features and Services	MMX8x4-HT400MC	MMX8x4-HT420M	MMX8x8-HDMI-4K-A
4K / UHD (30Hz RGB 4:4:4 60Hz YCbCr 4:2:0) and 3D capabilities	Yes	Yes	Yes
HDMI input ports	4x	4x	8x
TPS (HDBaseT) input ports	4x	4x	-
HDMI output ports	4x	2x	8x
TPS (HDBaseT) output ports	-	2x	-
Up to 170 m transmission over TPS Long Reach Mode for Full HD signals	-	Yes	-
Balanced bi-directional analog audio ports	-	2x	6x
Balanced analog audio output for the built-in mixer	1x	1x	-
Special Audio Input Block for active microphone and line-in	Yes	Yes	-
Built-in DSP, sound mixer and ducking function for voiceover	Yes	Yes	-
Ethernet port for device control	1x	1x	1x
Ethernet ports for external device control	-	2x	-
Ethernet via TPS	-	Yes	-
Bi-directional RS-232 ports	2x	2x	2x
Serial/IR ports for display control	2x	2x	2x
IR ports for display control	2x	4x	2x
Relay output ports	-	4x	-
GPIO port	-	6x GPIO + 5V + GND	-
PoE function to feed remote power to connected devices	-	Yes	-
Front panel LCD and jog dial button	Yes	Yes	Yes
Event Manager built-in control feature	Yes	Yes	Yes

1.5. Features of the Device



4K Video

Supporting uncompressed 4K UHD resolution at 30Hz 4:4:4 colorspace.



HDCP Compliant

Relevant inputs and outputs are fully HDCP compliant. HDCP capability on the HDMI inputs can be disabled when non-protected content is extended.



Advanced EDID Management

The user can emulate any EDID on the inputs independently, read out and store any attached monitor's EDID in internal memory locations, upload and download EDID files using Lightware Device Controller software.



Pixel Accurate Reclocking

Each output has a clean, jitter free signal, eliminating signal instability and distortion caused by long cables or connector reflections.



Frame Detector and Signal Analysis

The exact video and audio signal format can be determined such as timing, frequencies, scan mode, HDCP encryption, color range, color space and audio sample rate.



Graphic Display and Rotary Jog Dial Control Knob

Easy setting and menu navigation are assured by the color graphic display and the comfortable jog dial control.



Event Manager

The Event Manager tool takes care of all the necessary control in a smaller configuration by performing predefined actions in response to device status changes. Hence, in a less complex environment, there is no need to invest in additional control solutions, which makes the matrix the best choice for numerous applications.



DSP

The built-in DSP in select Lightware products provides audio mixer services including fader, ducking, equalizer, mute, balance and gain.

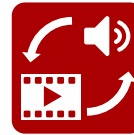

Audio Embedder and De-embedder Function

The analog audio can be embedded to HDMI outputs and embedded audio can be routed to the analog audio output.



Advanced Audio

Analog audio signals are still widely used in AV applications. The matrix switcher support direct analog audio connections to ease system integration. Analog audio ports feature volume and gain controls. These controls help to interface with an audio subsystem or if the ports are connected directly to audio sources or speakers they provide easy sound adjustment.



Special Audio Input Block for Microphone and Line-in

Special Audio Input block with input ports for microphone and line-in. The built-in sound mixer allows for free mixing of the microphone, the line-in and the de-embedded audio.



Infra

Infrared (IR) is a wireless technology used for device communication over short ranges. Third party control systems may send IR control commands to endpoints turning them on and off or switching their inputs.



Relay

Controllable relay modules up to 30V, 1A support.



GPIO Control Port

6 GPIO pins operating at TTL digital signal levels and can be controlled with both LW2 and LW3 commands.

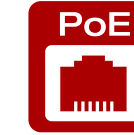

Remote Power

The MMX8x4-HT420M matrix is PoE-compatible. Power over Ethernet or PoE describes a standardized system which pass electric power along with data on twisted pair Ethernet (CAT) cabling. This allows a single cable to provide both data connection and electric power to remote devices.



Consumer Electronic Control

Supports transmitting standard CEC commands in order to remote control the source or sink device.

1.6. Typical Application

MMX8x4-HT400MC

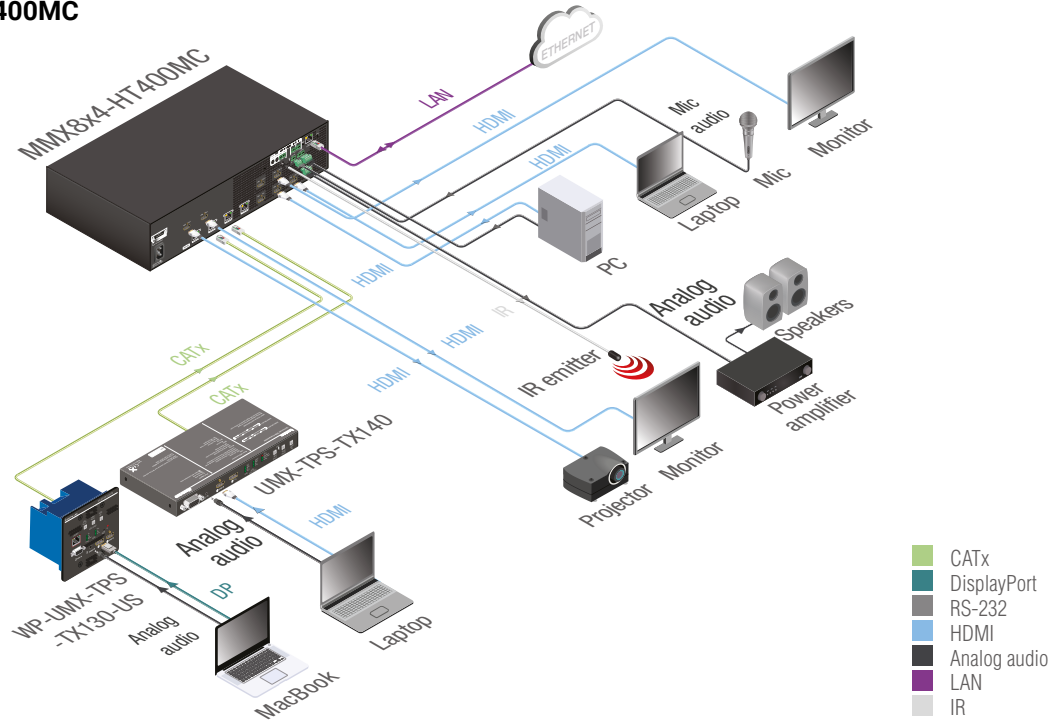

MMX8x4-HT420M

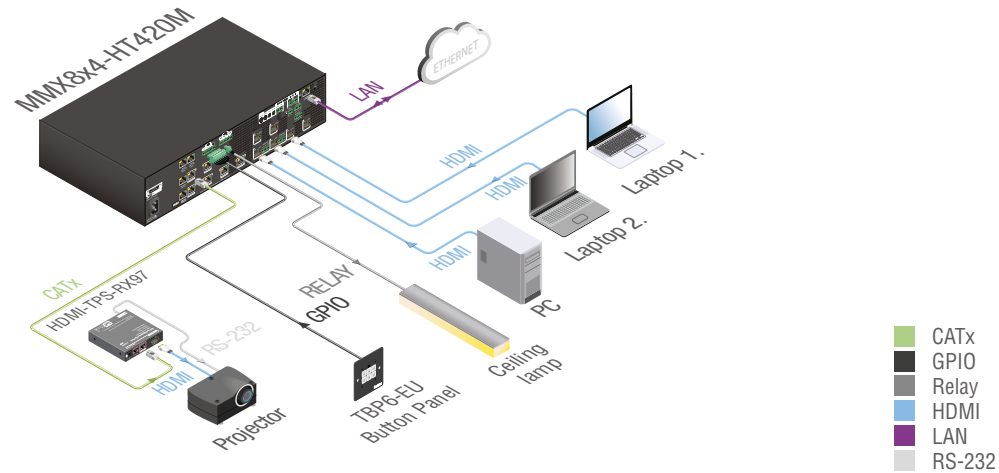

MMX8x8-HDMI-4K-A

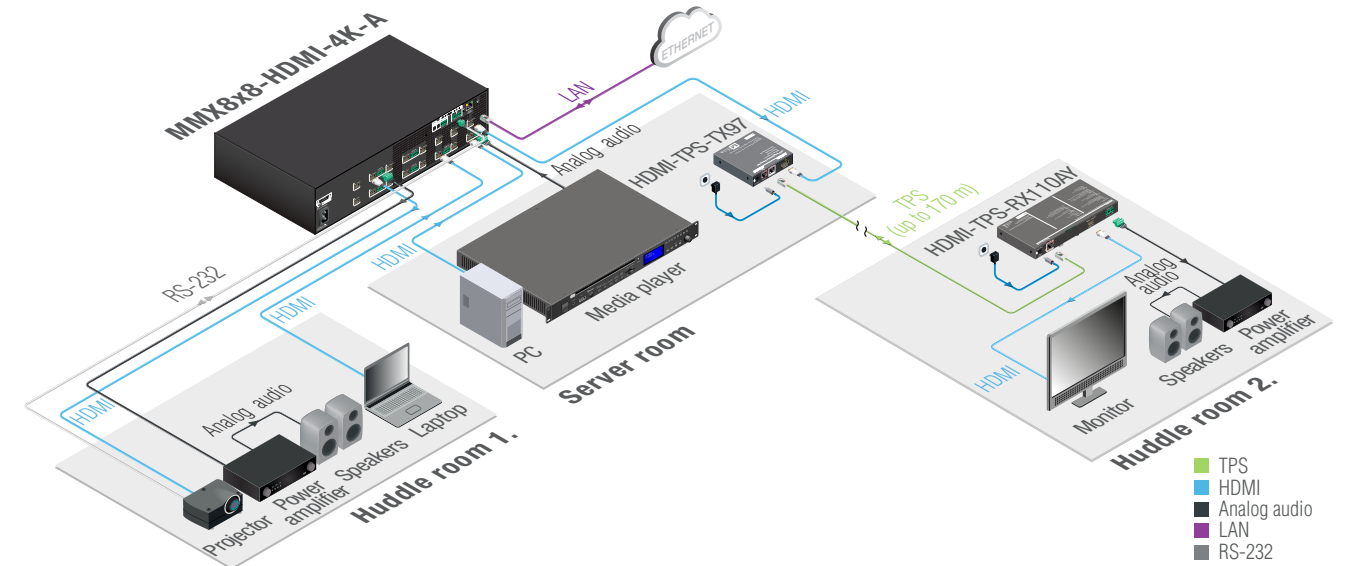

2

Installation

The chapter is about the installation of the device and connecting to other appliances, presenting also the mounting options and further assembly steps:

- ▶ [MOUNTING OPTIONS -STANDARD RACK INSTALLATION](#)
- ▶ [CONNECTING STEPS](#)
- ▶ [INSTALLATION GUIDE FOR CONNECTING A MICROPHONE](#)

2.1. Mounting Options -Standard Rack Installation

The matrix can be mounted in several ways by the supplied two rack ears. Allen head screws fix them to the housing.

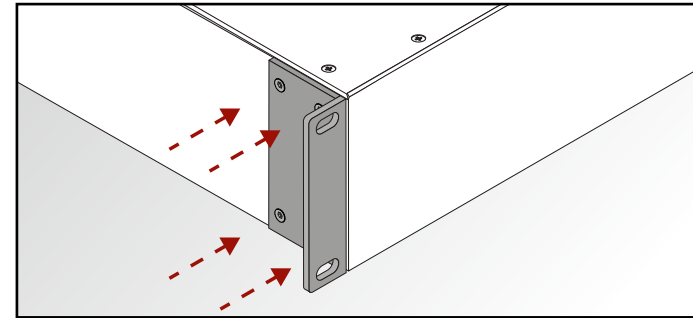

ATTENTION! M4x10 size is the longest allowed screw for fixing the ears to the housing. A longer screw may touch internal parts.

Two rack ears are supplied with the product, which are fixed on left and right side as shown in the picture. The default position allows mounting the device as a standard rack unit installation.

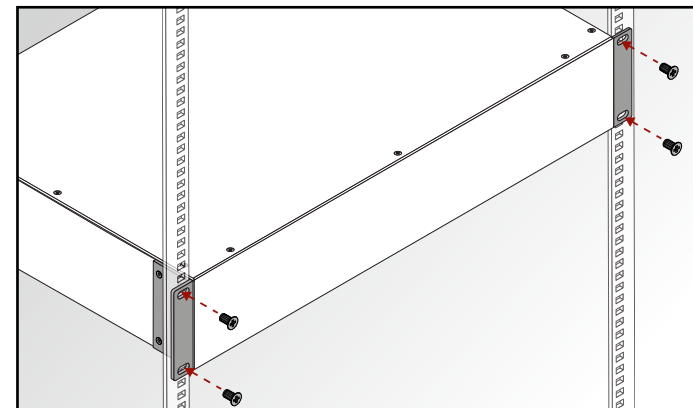

Standard rack installation

ATTENTION! Always use all the four screws for fixing the rack shelf ears to the rack rail. Choose properly sized screws for mounting. Keep minimum two threads left after the nut screw.

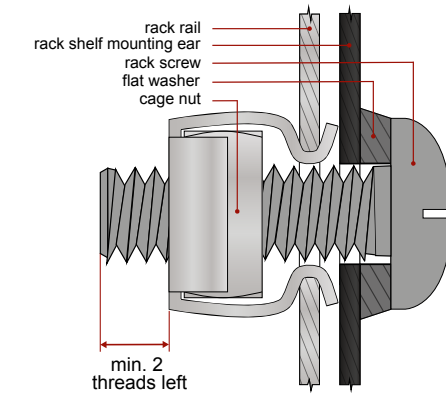

Mounting the device to the rack rail

INFO: The matrix switcher is one rack wide and 2U high.

WARNING! Never block the ventilation holes on any side of the matrix! Ensure the proper ventilation by letting the free airflow.

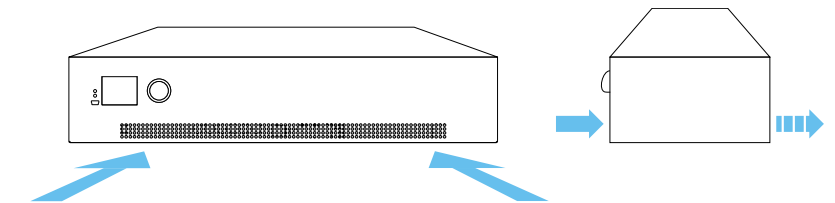

Direction of the airflow

2.2. Connecting Steps

MMX8x4-HT400MC, MMX8x4-HT420M models

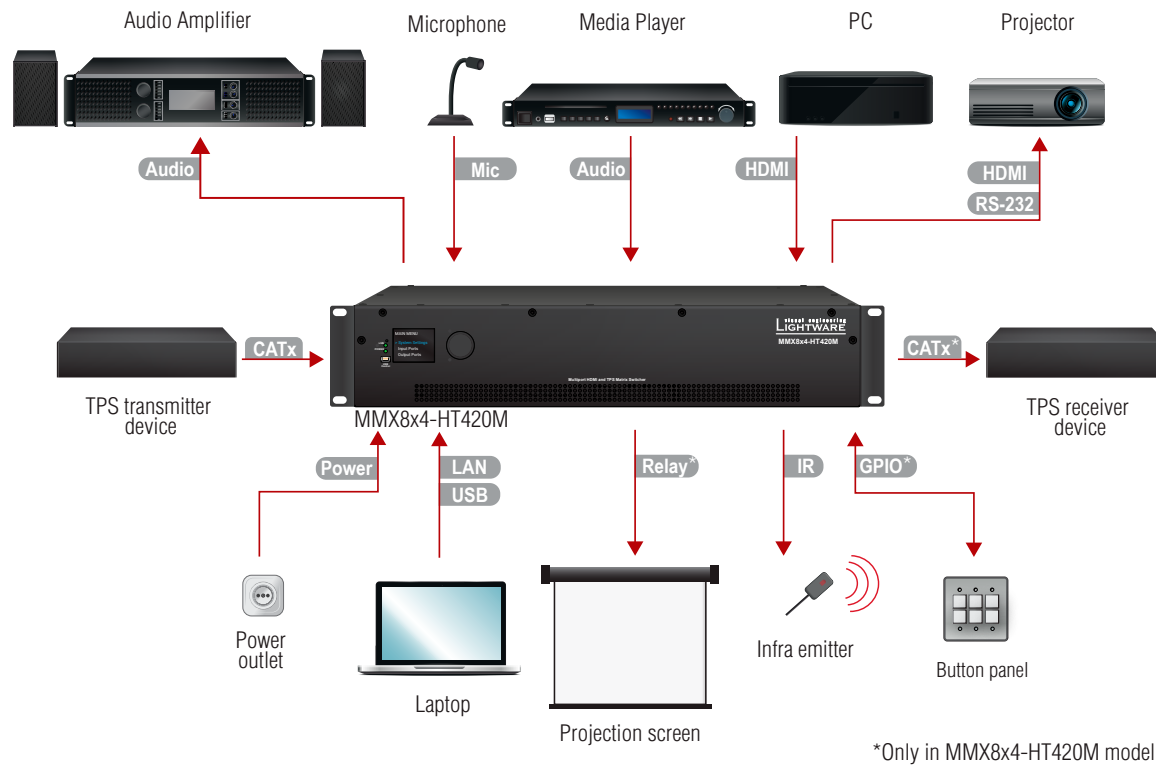

MMX8x8-HDMI-4K-A model

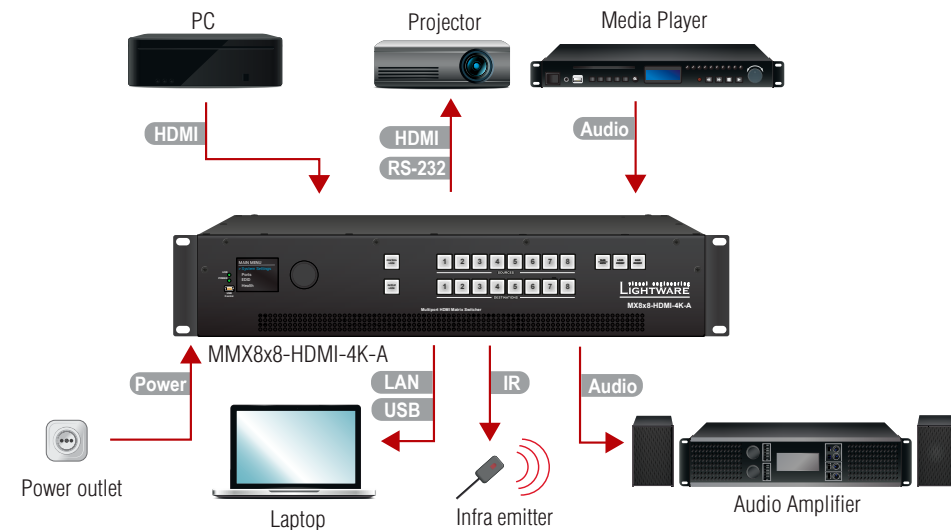

- CATx** Connect an HDBase-T™-compatible transmitter or matrix output board to TPS input port. MMX8x4-HT400MC model is not PoE-compliant, and MMX8x4-HT420M model is PoE compliant.
- HDMI** Connect an HDMI source (e.g. PC) to the HDMI input port.
- HDMI** Connect an HDMI sink (e.g. projector) to the HDMI output port.
- Audio** Optionally for analog output: connect an audio device (e.g. audio amplifier) to the analog audio output port by an audio cable.
- Mic** Please read the [Installation Guide for Connecting a Microphone](#) section before connecting the microphone to the matrix. Not proper setting could damage the device.
- Audio** Optionally for audio input: connect the audio source (e.g. media player) to the audio input port by an audio cable.
- USB** Optionally connect the USB cable in order to control the matrix switcher via Lightware Device Controller software.
- LAN** Optionally connect the UTP cable (straight or cross, both are supported) in order to control the matrix switcher via the Lightware Device Controller software.
- Relay** Optionally for relays: connect a controlled device(s) (e.g. a projection screen) to the relay port.*
- IR** Optionally connect the infra emitter to the infra output port (2-pole Phoenix or 1/8" Stereo Jack connector) to transmit infra signal.
- GPIO** Optionally connect a controller/controlled device (e.g. button panel) to the GPIO port.*
- Power** Connect the power cord to the AC power socket to the matrix unit. It is recommended to power on the devices as the final step.

*Only in MMX8x4-HT420M model.

2.3. Installation Guide for Connecting a Microphone

MMX8x4-HT400MC and MMX8x4-HT420M model

The device features a dedicated Special Audio Input Block for microphone. Before connecting a microphone to the matrix device please read the instructions below.

These settings can be done from a computer using the [Software Control – Lightware Device Controller](#) (LDC) software. The application is available at www.lightware.com, install it on a Windows PC or a macOS and connect to the device via LAN, USB, RS-232.



Step 1. Always check the correct wiring of the microphone cable. See more details about the wiring in [Audio Cable Wiring Guide](#) section. Microphone cable should be shielded with 2x0,22mm conductor, max. 50m long.

WARNING! Never apply phantom power with unbalanced cable, because it may harm the devices!

Step 2. Before the connection, please set these properties below:

Port	Property	Value	Lightware Device Controller	LW3 command
Advanced audio output (AUDIO OUT)	Volume	-80dB and/or Mute		<ul style="list-style-type: none"> ▶ SET /MEDIA/AUDIO/O6.Volume=-80 ▶ SET /MEDIA/AUDIO/O6.Mute=true
	Volume	-80dB and/or Mute		<ul style="list-style-type: none"> ▶ SET /MEDIA/AUDIO/I9.Volume=-80 ▶ SET /MEDIA/AUDIO/I9.Mute=true
Microphone input (MIC IN)	ATTENTION! Skipping the volume or mute setting can cause serious damage in the speaker or the external sound system when phantom power is turned on!			
	Phantom power	Off		▶ SET /MEDIA/AUDIO/I9.PhantomPower=false
	ATTENTION! Always turn off the phantom power before connecting the microphone! INFO: When the red LED lights on the rear side of the matrix, it displays that the phantom power is switched on.			
	Input gain	-12dB		▶ SET /MEDIA/AUDIO/I9.InputGain=-12
	EQ (High,Hmid, Lmid, Low)	0		<ul style="list-style-type: none"> ▶ SET /MEDIA/AUDIO/I9.PEQ1Gain=0 ▶ SET /MEDIA/AUDIO/I9.PEQ2Gain=0 ▶ SET /MEDIA/AUDIO/I9.PEQ3Gain=0 ▶ SET /MEDIA/AUDIO/I9.PEQ4Gain=0
	Panorama (Balance)	0		▶ SET /MEDIA/AUDIO/I9.Balance=0

For more information about the LW3 protocol commands, see [LW3 Programmers' Reference](#) section.

Step 3. Connect the microphone.

- a) In case of **dynamic or wireless microphone**: Skip this step and follow the instructions with **Step 4**.
- b) In case of **condenser microphone**: Switch on the phantom power. Keep pressed the button more than 2 seconds to activate phantom power.

Port	Property	Value	Lightware Device Controller	LW3 command
Microphone input (MIC IN)	Phantom power	On		▶ SET /MEDIA/AUDIO/I9.PhantomPower=true

WARNING! Phantom power supplies the condenser microphone by 48V via the microphone cable which is necessary for normal operation of the condenser microphone. Application of the phantom power can cause a damage if dynamic or wireless microphone is connected.

INFO: Always switch on the phantom power when the cabling and connecting have already done. Do not disconnect the microphone when the phantom power is switched on!

Step 4. Set these properties below:

Port	Property	Value	Lightware Device Controller	LW3 command
Advanced audio output (AUDIO OUT)	Volume	0dB		▶ SET /MEDIA/AUDIO/O6.Volume=0
Microphone input (MIC IN)	Volume	0dB		▶ SET /MEDIA/AUDIO/I9.Volume=0

Step 5. Talk to the microphone continuously. Increase the microphone input gain slowly and check the signal indicator chart. It gives a feedback about the optimal signal level.

INFO: Take care that peak led (PK!) never lights up! See more details in [Panorama or Balance Settings](#) section.

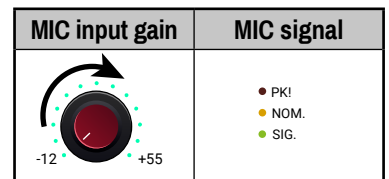

Step 6. If the signal level is low, set the optimal volume both the microphone input and balanced output channel. Always check the signal indicator chart for the optimal level!

INFO: Take care that peak led (PK!) never lights up! See more details in [Panorama or Balance Settings](#) section.

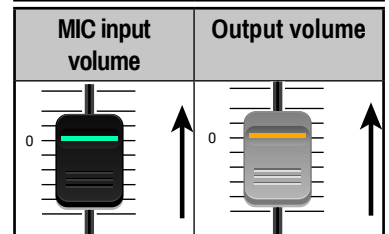

3

Product Overview

The following sections are about the physical structure of the device, input/output ports and connectors:

- ▶ FRONT VIEW
- ▶ REAR VIEW
- ▶ ELECTRICAL CONNECTIONS
- ▶ HDMI AND TPS MATRIX CONCEPT
- ▶ TPS INTERFACE
- ▶ VIDEO INTERFACE
- ▶ AUDIO INTERFACE
- ▶ CONTROL FEATURES

3.1. Front View

MMX8x4-HT400MC, MMX8x4-HT420M

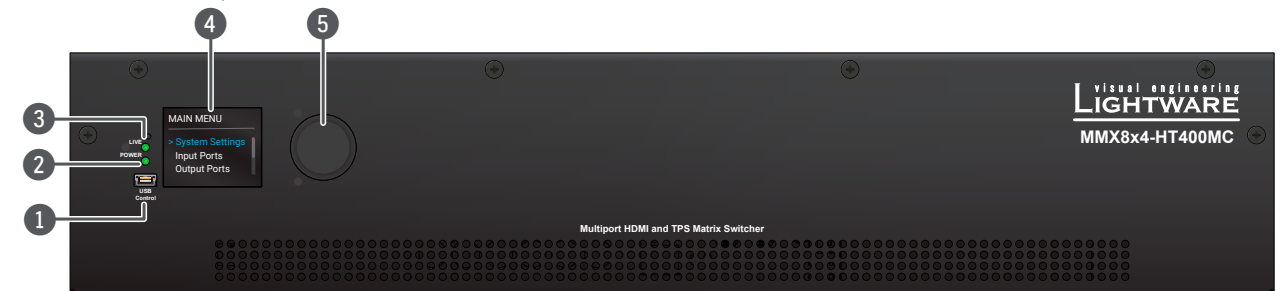

INFO: Both the two models have the same look and controls on the front panel.

MMX8x8-HDMI-4K-A

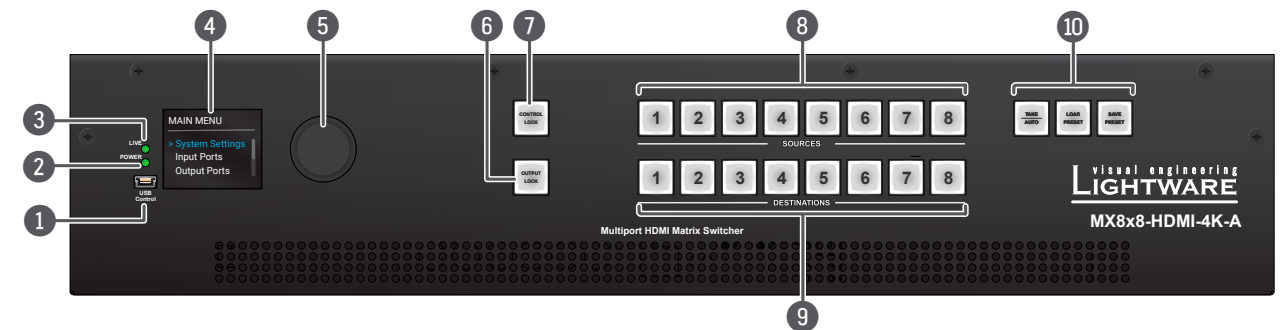

- | | |
|--|---|
| <p>1 USB Port</p> <p>2 POWER LED</p> <p>3 LIVE LED</p> <p>4 LCD Display</p> <p>5 Jog Dial Knob</p> <p>6 Output Lock*</p> <p>7 Control Lock*</p> <p>8 Sources*</p> <p>9 Destinations*</p> <p>10 Function Buttons*</p> | <p>USB connector for local control functions (e.g. Lightware Device Controller software).</p> <p> ● on POWER LED indicates that the unit is powered on.
 ○ off The unit is powered off or internal voltage problem. </p> <p> ☀ blinking slow The unit is on and operates properly.
 ☀ blinking fast The unit is in bootload mode. </p> <p>LCD screen showing the most important settings in the front panel menu.</p> <p>Easy setting and menu navigation by the jog dial control. Keep dial and click while getting feedback on the LCD.</p> <p>Locking one or more outputs.</p> <p>Disable or enable front panel operations. Red light means the switching and function buttons are disabled.</p> <p>Buttons to select an input, to select a preset number or to view the state of the selected input port.</p> <p>Buttons to select an output or to view the state of an output.</p> <p>Switching between working modes (Take / Autotake) and performing Preset operations.</p> |
|--|---|

* Only in MMX8x8-HDMI-4K-A model.

3.2. Rear View

MMX8x4-HT400MC

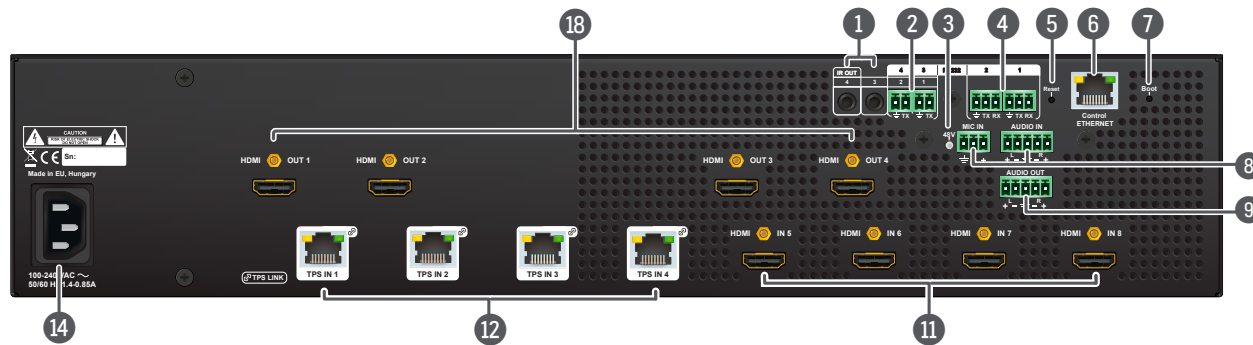

MMX8x4-HT420M

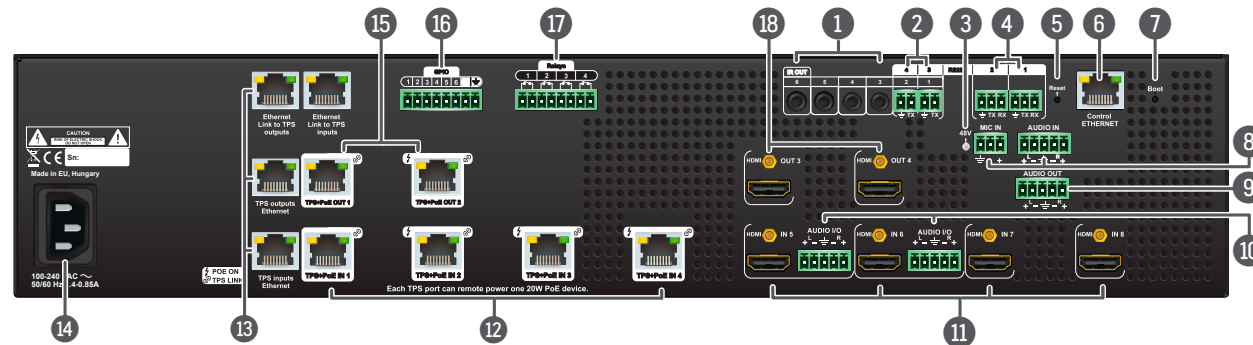

MMX8x8-HDMI-4K-A

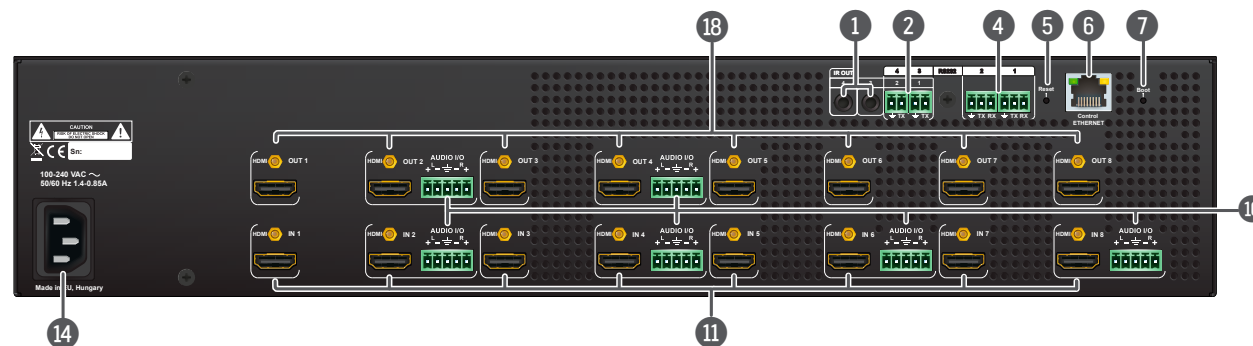

Rear View Legend

- 1 **Infra output ports** 3.5 mm Jack plugs for infra signal transmission (all of them are outputs).
- 2 **Serial/Infra output ports** 2-pole Phoenix connectors (2x) for IR output or TTL output serial signal.
- 3 **48 V LED**
 - On This LED lights, when phantom power is turned on.
 - Off The phantom power is turned off.
- 4 **RS-232 port** 3-pole Phoenix connectors (2x) for bi-directional RS-232 communication. Local control functions (e.g. Lightware Device Controller software) and message sending are also possible via RS-232 port. See more details in [RS-232 Connector](#) section.
- 5 **Reset button** Reboots the matrix; the same as switching it off and on again.
- 6 **Control Ethernet port** RJ45 connector to control the matrix via LAN. See more details in [Control Ethernet Port](#) section.
- 7 **Boot button** Hidden button for bootload mode (keep pressed the boot button and turn on the matrix to take it bootload mode).
- 8 **Advanced audio input ports** 3- pole Phoenix connector for microphone input and 5-pole Phoenix connector for balanced analog audio input. See details about the audio features in [Audio Interface](#) section.
- 9 **Advanced audio output port** 5-pole Phoenix connector for balanced analog audio; the signal can be the embedded audio from the TPS or HDMI inputs or from the microphone input or from the line in. See details about the audio features in [Audio Interface](#) section.
- 10 **Audio inputs/ outputs** 5-pole Phoenix connector for balanced analog audio; depending on the configuration, it can be input or output. Output audio is the de-embedded HDMI signal from the nearby HDMI port. See details about the audio features in [Audio Interface](#) section.
- 11 **HDMI inputs** HDMI input ports for sources.
- 12 **TPS inputs** RJ45 connectors for incoming TPS signal.
 - MMX8x4-HT400MC and model is **not** PoE-compliant.
 - MMX8x4-HT420M model is PoE-compliant.
- 13 **TPS Ethernet** Locking RJ45 connector to supply Ethernet communication for the TPS lines – it can be separated from the LAN communication (controlling functions) of the matrix. Not PoE-compliant. Pin assignment can be found in [Ethernet Link to TPS Input/Output Ports](#) section.
- 14 **AC connector** Local power in; standard IEC connector accepting 100-240 V, 50 or 60 Hz.
- 15 **TPS Outputs** RJ45 connectors for TPS signal; PoE-compliant.
- 16 **GPIO** 8-pole Phoenix connector for configurable general purpose input/output ports. Pin assignment can be found in the [GPIO - General Purpose Input/Output Ports](#).
- 17 **Relay** 8-pole Phoenix connector for relay ports. Pin assignment can be found in the [Relay Connector](#) section.
- 18 **HDMI outputs** HDMI output connectors for sinks.

3.3. Electrical Connections

3.3.1. HDMI Input and Output Ports

The matrix switchers are assembled with standard 19-pole HDMI connectors with screw lock for inputs and outputs. Always use high quality HDMI cable for connecting sources and displays.



3.3.2. Analog Stereo Audio

5-pole Phoenix connector is used for balanced analog audio input or output. Unbalanced audio signals can be connected as well. See more details about the balanced and unbalanced I/O port wiring in the [Audio Cable Wiring Guide](#) section.



Pin nr.	Signal
1	Left+
2	Left-
3	Ground
4	Right-
5	Right+

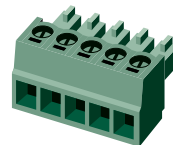

Analog audio connector and plug pin assignments

Compatible Plug Type

Phoenix® Combicon series (3.5mm pitch, 5-pole), type: MC 1.5/5-ST-3.5.

3.3.3. Microphone IN

INFO: MMX8x8-HDMI-4K-A model has no microphone input.

The 3-pole Phoenix connector is used for the analog microphone input. 48V phantom powering is available via connector.

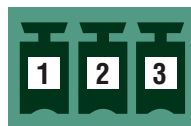

Pin nr.	Signal
1	Ground
2	-
3	+

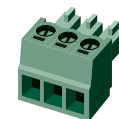

Microphone connector and plug pin assignments

INFO: The maximum rating of Microphone input is 48V and 7mA.

Compatible Plug Type

Phoenix® Combicon series (3.5mm pitch, 3-pole), type: MC 1.5/3-ST-3.5.

You can find more information about the wiring in the [Audio Cable Wiring Guide](#) section and about the connection in [Installation Guide for Connecting a Microphone](#) section.

3.3.4. RS-232 Connector

The receiver contains a 3-pole Phoenix connector which is used for RS-232 serial connection.



Pin nr.	Signal
1	Ground
2	TX data
3	RX data

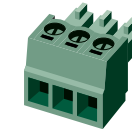

RS-232 connector pin assignments

RS-232 Output Voltage Levels

- Logic low level: 3V .. 15V
- Logic high level: -15V .. -3V

Compatible Plug Type

Phoenix® Combicon series (3.5mm pitch, 3-pole), type: MC 1.5/3-ST-3.5.

You can find more information about RS-232 in [Serial Interface](#) section.

3.3.5. Infra/ Serial TTL Connector

The matrix switcher contains a 2-pole Phoenix connector. Depending on the destination port, it can be used for TTL serial data output or Infra emitter.



Pin nr.	Signal
1	Ground
2	TX data

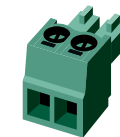

Infra/ TTL serial connector pin assignments

TTL digital signal levels can be set to high or low level (Push-Pull).

Using a receiver with at least 1k impedance to any voltage between 0V and 5V, the output voltages are:

- Logic low level: 0 .. 0.25V
- Logic high level: 4.75 .. 5.0V

In that case the actual current is:

- Logic low level: -5mA < current < 0mA (sink)
- Logic high level: 0mA < current < 5mA (source)

Compatible Plug Type

Phoenix® Combicon series (3.5mm pitch, 2-pole), type: MC 1.5/2-ST-3.5.

You can find more information about TTL in the [Serial Interface](#) section and about Infrared in the [Infra Interface](#) section.

3.3.6. IR Connector

IR emitter can be connected to the matrix switcher with TRS (Tip, Ring, and Sleeve) connectors. They are also known as (3.5 mm or approx. 1/8") audio jack, phone jack, phone plug, and mini-jack plug.

The pin assignments are the following :

Emitter – 2-pole-TS	
1 Tip	+5V
2 Ring	Signal (active low)
3 Sleeve	

INFO: Ring pole of the emitter is optional. If your IR emitter has three pole- TRS plug, then the Ring and the Sleeve are the same signal (Output -).

You can find more information in the [Infra Interface](#) section.

3.3.7. Control Ethernet Port

The matrix contains an RJ-45 connector for Ethernet/LAN connection for local control functions.

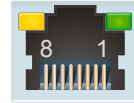

The Ethernet ports can be connected to a LAN hub, switch or router by a CATx cable. However both cable types (straight or cross) are supported and handled by the device, below pin assignment is recommended.

Wiring of LAN Cables

Lightware recommends the termination of LAN cables on the basis of TIA/EIA T 568 A or TIA/EIA T 568 B standards.

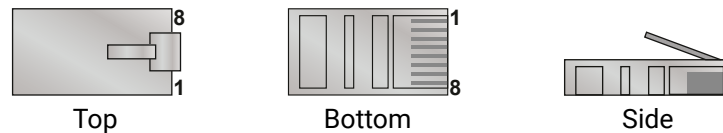

Pin	Name	Color and name	
1	TX +		white/green stripe
2	TX -		green solid
3	RX +		white/orange stripe
4	Not used		blue solid
5	Not used		white/blue stripe
6	RX -		orange solid
7	Not used		white/brown stripe
8	Not used		brown solid

	LED1	green		on	100 Mbit/s
				off	0 Mbit/s
	LED2	amber		on	no activity
				off	not linked
				blinking	activity

3.3.8. Ethernet Link to TPS Input/Output Ports

MMX8x4-HT420M model contains RJ45 connector to supply Ethernet communication for the TPS lines – it can be separated from the LAN communication. This function allows controlling external devices. Not PoE-compliant. See more information in [Ethernet Interface](#) section.

3.3.9. TPS Input/Output Ports

MMX8x4-HT400MC

This variant provides four standard RJ45 connectors for TPS input ports. **Not** PoE-compatible.

MMX8x4-HT420M

This model has four TPS inputs and two TPS outputs. PoE-compatible, each port can remote power 20W PoE device.

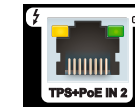

INFO: MMX8x8-HDMI-4K-A model has no TPS input/output connectors.

3.3.10. GPIO - General Purpose Input/Output Ports

MMX8x4-HT420M model contains a 8-pole Phoenix connector with six GPIO pins, which operates at TTL digital signal levels and can be set to high or low level (Push-Pull). The direction of the pins can be input or output (adjustable). Voltage ranges for GPIO inputs are the following:



	Input voltage [V]	Output voltage [V]	Max. output current [mA]
Logical low level	0 - 0.8	0 - 0.5V	30
Logical high level	2 - 5	4.5 - 5V	18

INFO: The maximum total current for the seven GPIO pins is 180 mA.

Pin nr.	Level and direction
1	Configurable
2	
3	
4	
5	
6	
5V	
Ground	

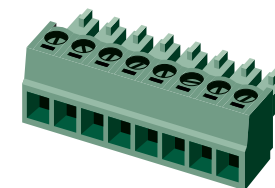

GPIO connector and plug pin assignments

Compatible plug type

Phoenix® Combicon series (3.5mm pitch 8-pole), type: MC 1.5/8-ST-3.5. You can find more information in [GPIO Interface](#) section.

3.3.11. USB Connector

MMX8x4-HT series have standard USB mini-B receptacle.



3.3.12. Relay Connector

The MMX8x4-HT420M model contains a 8-pole Phoenix connector which is used for relay connection. The relays are potential free.



Pin nr.	Signal
1	Pin 1 for Relay 1
2	Pin 2 for Relay 1
3	Pin 1 for Relay 2
4	Pin 2 for Relay 2
5	Pin 1 for Relay 3
6	Pin 2 for Relay 3
7	Pin 1 for Relay 4
8	Pin 2 for Relay 4

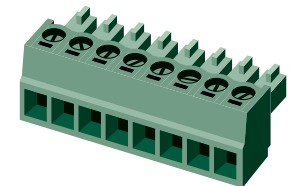
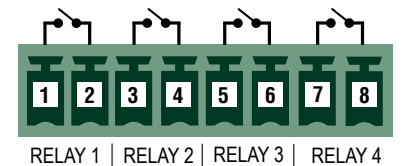

Relay connector pin assignment

INFO: The maximum ratings for each relay are 30V and 1A, AC/DC.

Compatible Plug Type

Phoenix® Combicon series (3.5mm pitch, 4-pole), type: MC 1.5/4-ST-3.5. You can find more information about relay interface in the [Relay Interface](#) section.

3.4. HDMI and TPS Matrix Concept

MMX8x4 series devices are multifunctional audio/video matrix switchers with eight inputs and four outputs. The matrix gives the possibility to route many kinds of signal formats including TPS and other available interfaces. This chapter is about to present the features and limitations of these interfaces.

Summary of Interfaces - MMX8x4-HT400MC



Summary of Interfaces - MMX8x4-HT420M



Summary of Interfaces - MMX8x8-HDMI-4K-A



3.5. TPS Interface

The matrix gives the possibility to route many kinds of signal formats including TPS and other available interfaces. This chapter is about to present the features and limitations of these interfaces.

ATTENTION! MMX8x4-HT400MC and MMX8x4-HT420M models have different signal extension capability. Please check the TPS cable length in the [Maximum Extension Distances](#) section.

Summary of TPS Ports

	TPS IN			TPS OUT		
	Connector type	Nr.	Transmitted signal	Connector type	Nr.	Transmitted signal
MMX8x4-HT400MC	RJ45	4x	HDMI, RS-232	-	-	-
MMX8x4-HT420M	RJ45	4x	HDMI, RS-232, Ethernet	RJ45	2x	HDMI, RS-232, Ethernet
MMX8x8-HDMI-4K-A	-	-	-	-	-	-

3.5.1. TPS Working Modes

The TPS working mode between the transmitter and the receiver parties is determined by the mode set in them. Both parties influence on the setting which determines the final TPS transmission mode.

The following TPS modes are defined in the matrix:

Available TPS modes in MMX8x4-HT400MC model	Available TPS modes in MMX8x4-HT420M model	Explanation
Auto	Auto	The TPS mode is determined automatically.
HDBaseT	HDBaseT	Ideal for high resolution signals up to 4K but with a shorter cable.
-	Long reach	Ideal for big distances up to 1080p@60Hz.
LPPF1*	LPPF1*	Only RS-232 communication is transmitted (@ 9600 baud).
-	LPPF2*	Only RS-232 (@ 9600 baud) and Ethernet communication are transmitted.

* LPPF: Low Power Partial Functionality

For more information about the TPS cable length see [Maximum Extension Distances](#) section.

Above settings refer to the matrix. The table below details the system's state with regard to mode selection behavior for all possible combinations for both ends of the link:

MMX8x4-HT400MC

		Selected mode on TPS input (RX side)		
		LPPF1	HDBaseT	Auto
Selected mode on TX side	LPPF1	LPPF1	LPPF1	LPPF1
	LPPF2	LPPF1	LPPF1	LPPF1
	HDBaseT	LPPF1	HDBaseT	HDBaseT
	Long reach	LPPF1	LPPF1	LPPF1
	Auto	LPPF1	HDBaseT	HDBaseT *

* If there is valid HDMI/DVI signal is on the TX side, the TPS mode will be HDBaseT on both side. If the transmitter does not transmits HDMI/DVI signal, the TPS mode will be changed to LPPF1 automatically.

MMX8x4-HT420M

		Selected mode on RX side				
		LPPF1	LPPF2	HDBaseT	Long reach	Auto
Selected mode on TX side	LPPF1	LPPF1	LPPF1	LPPF1	LPPF1	LPPF1
	LPPF2	LPPF1	LPPF2	LPPF2	LPPF2	LPPF2
	HDBaseT	LPPF1	LPPF2	HDBaseT	Long reach	HDBaseT
	Long reach	LPPF1	LPPF2	Long reach	Long reach	Long reach
	Auto	LPPF1	LPPF2	HDBaseT	Long reach	HDBaseT *

* If there is valid HDMI/DVI signal is on the TX side, the TPS mode will be HDBaseT on both side. If the transmitter does not transmits HDMI/DVI signal, the TPS mode will be changed to LPPF2 automatically. Long reach mode is not available when both sides are set to Auto mode.

When using automatic operation mode selection, the device uses built-in sensors to determine the mode of operation. If both parties are set to Auto mode, the source side is the initiator. It will negotiate each state transition with its sink side partner.

When one of the devices is configured to manual operation mode selection, the other device may be placed in automatic mode. In this case, the mode transition negotiation is initiated by the host-managed device and the auto-mode device follows through. The allowed cable lengths and resolutions are listed in [Maximum Extension Distances](#) section.

3.5.2. Power over Ethernet (PoE)

WARNING! The remote power feature of TPS 95 series extenders is not PoE-compatible. Thus, TPS 95 series cannot be powered remotely by the MMX8x4 matrix switchers (but the video signal is transmitted to/from the extenders). If a TPS 95 extender is connected to the matrix, make sure that the remote power jumper of the extender is removed or set to 'Remote power disabled' position.

MMX8x4-HT420M

INFO: MMX8x4-HT420M model has PoE support.

TPS input and output ports are able to supply other HDBase-T compliant devices over the TPS lines which are PoE-compliant as well. In this case, the connected transmitter or receiver does not require a local power supply.

ATTENTION! The Ethernet ports do not support PoE. Only the TPS ports have PoE function.

The PoE feature in the practice

The TPS ports of the matrix are in accordance with IEEE 802.3af (PoE) standard. The feature is demonstrated on below figure:

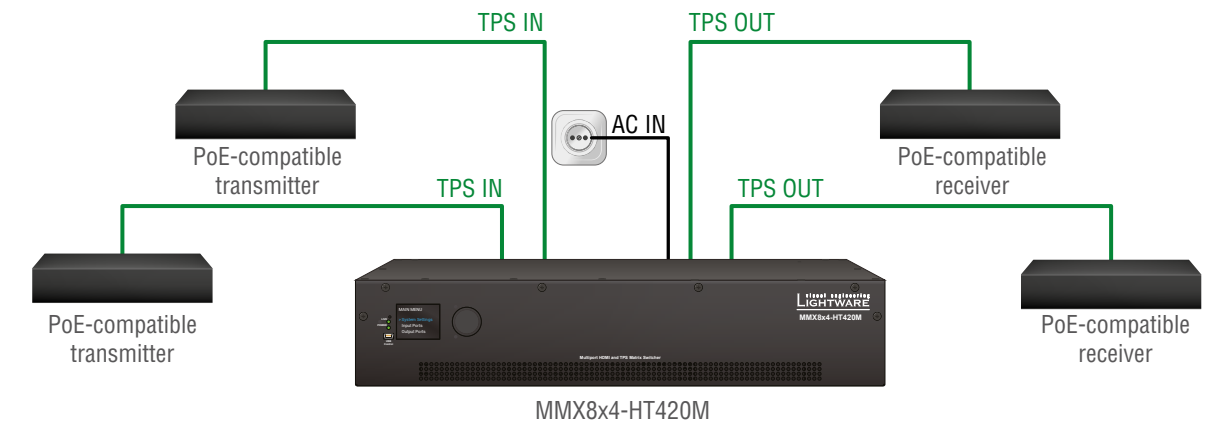

Extenders Supplied without Local Power

The concept

Supply the connected extenders through the CATx (TPS) cables without local adapters.

Settings

- **Extenders:** the device must be PoE-compatible or else the feature will not work.
- **Matrix:** make sure the PoE option on the TPS port is enabled (which is the default setting) via LDC in the port properties window; see [TPS Input Port Properties](#) and [HDMI and TPS Output Port Properties](#) section.

INFO: PoE-compatible and not compatible devices can be connected simultaneously as the feature can be set individually on each port.

3.6. Video Interface

Summary of Video Interfaces

The table below shows the number of the video signals and connector types by model.

Model type	INPUT		OUTPUT	
	Connector type	Connector type	Connector type	Connector type
MMX8x4-HT400MC	TPS	4x	HDMI	4x
	HDMI	4x		
MMX8x4-HT420M	TPS	4x	HDMI	2x
	HDMI	4x	TPS	2x
MMX8x8-HDMI-4K-A	HDMI	8x	HDMI	8x

The video crosspoint settings can be controlled by any of the following ways:

- Using Lightware Device Controller (for more information, see [Crosspoint Menu](#) section),
- Sending LW2 or LW3 protocol command, (for LW2 commands, see [Switch One Input to One Output](#) section or LW3 commands, see the [Switching and Crosspoint Settings](#) section),
- Using the Autoselect function (for more details see [The Autoselect Feature](#) section),
- Using the front panel LCD menu (for more information, see [Crosspoint Menu](#) section), or
- Pressing the Source and Destination buttons on the front panel* (see [Switching Operations](#) section).

* Only in MMX8x8-HDMI-4K-A model.

3.6.1. Port Diagram of MMX8x4-HT400MC

The following figure describes the port diagram of the MMX8x4-HT400MC matrix:

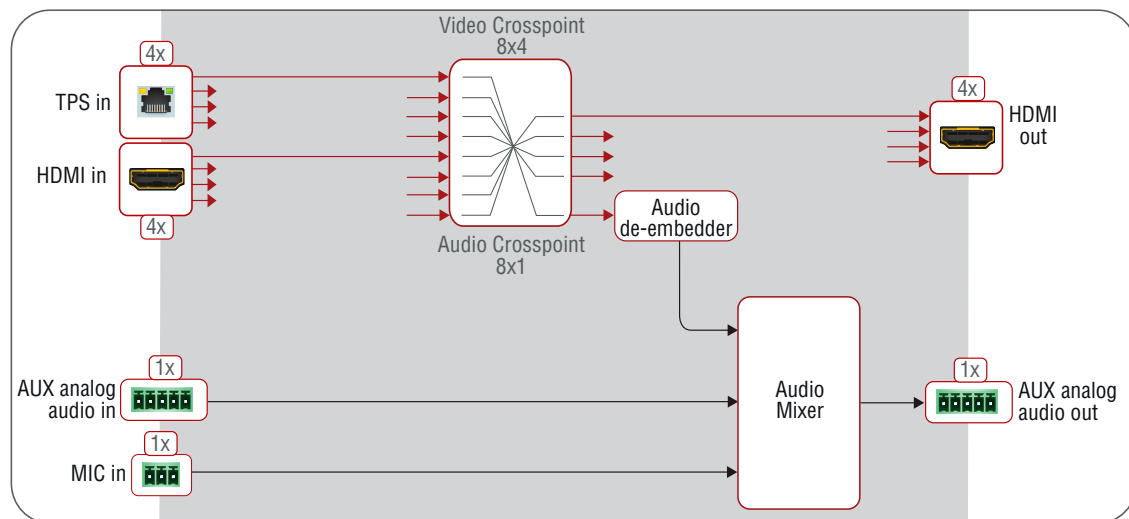

3.6.2. Port Diagram of MMX8x4-HT420M

The following figure describes the port diagram of the MMX8x4-HT420M matrix:

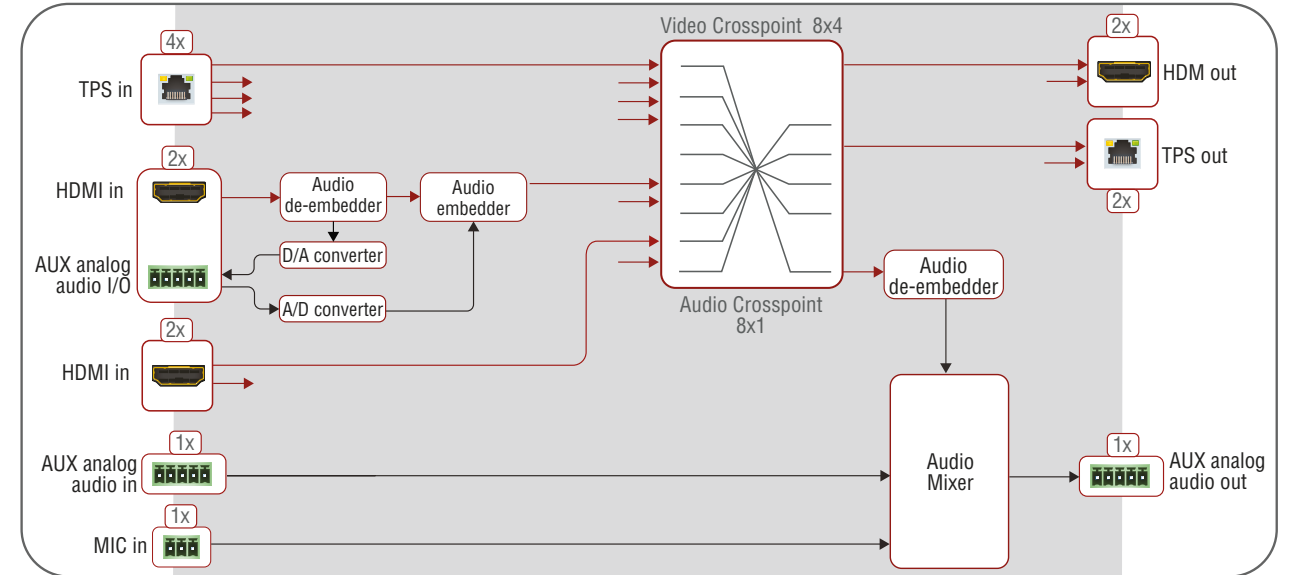

3.6.3. Port Diagram of MMX8x8-HDMI-4K-A

The following figure describes the port diagram of the MMX8x8-HDMI-4K-A matrix:

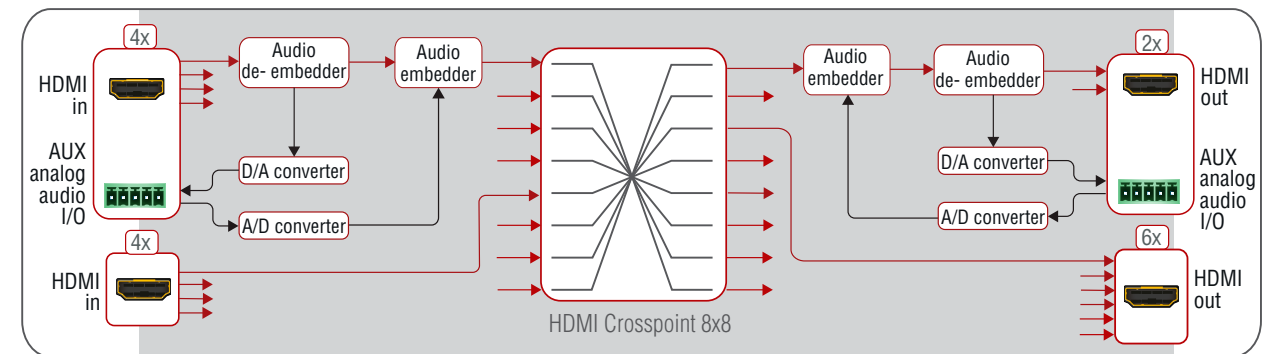

3.6.4. The Autoselect Feature

The autoselect mode can be set on output ports for each input with Lightware Device (LDC) Controller software (see more info about it in [HDMI and TPS Output Port Properties](#) section) or with the LW3 protocol (see more info about it in [Change the Autoselect Mode](#) section).

INFO: An input port is active if there is a valid signal on it.

There are three types of Autoselect as follows:

First detect mode: Selected input port is kept connected to the output while it has an active signal.

Priority detect mode: Always the highest priority active input is selected to transmit.

The proper priority setting requires fulfill the conditions below:

- Match the priority to the input ports. 0 means the highest, 7 means the lowest priority. If two inputs have the same priority number, the lower port number gets higher priority.
- Certain inputs can ignore by clicking the green tick or write **31** instead of the priority number. This port will be not scanned. See more details about this setting in [Query the Input Port Priority](#) section.
- Always confirm the settings by clicking on **Set priorities** button.

Last detect mode: Always the last attached input is selected to transmit.

See the Flowchart of Autoselect Modes in the Appendix chapter.

INFO: Autoselect mode is always disabled on locked output. If the crosspoint is changed manually, the autoselect function became also disabled.

3.7. Audio Interface

The table below shows the number of the audio signals and connector types by model.

Summary of Audio Interface

Model	Audio inputs				
	HDMI input	TPS input	Analog audio input	Advanced analog audio input	MIC input
MMX8x4-HT400MC	4x	4x	-	1x	1x
MMX8x4-HT420M	4x	4x	2x ¹	1x	1x
MMX8x8-HDMI-4K-A	8x	-	6x ²	-	-

Model	Audio outputs			
	HDMI output	TPS output	Analog audio output	Advanced analog audio output
MMX8x4-HT400MC	4x	-	-	1x
MMX8x4-HT420M	2x	2x	2x ¹	1x
MMX8x8-HDMI-4K-A	8x	-	6x ²	-

¹ Input or output, depending on the configuration. Sum of the analog audio inputs and outputs is two.

² Input or output, depending on the configuration. Sum of the analog audio inputs and outputs is six.

Advanced audio settings

The MMX8x4-HT400MC and MMX8x4-HT420M models have a dedicated Special Audio Input block with input ports for microphone and advanced analog line-in. The built-in audio mixer allows for free mixing of the microphone or the advanced analog line-in and the de-embedded audio from one of the input HDMI signals.

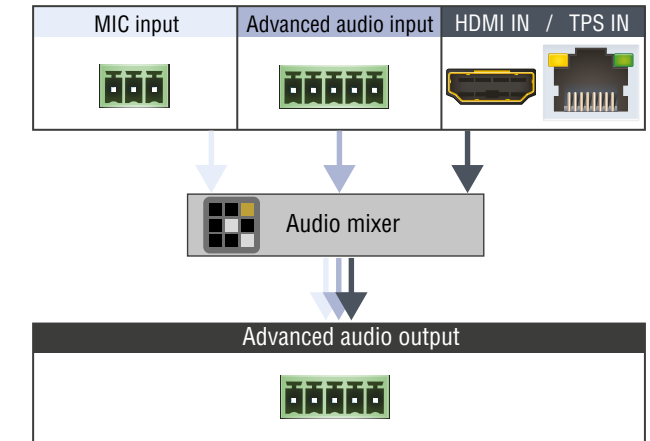

Audio ports of the built-in audio mixer

Advanced audio properties of the audio ports are available in [Audio Tab](#) in Lightware Device Controller Software (LDC) or via LW3 control protocol (in [LW3 Programmers' Reference](#) section).

See more details about the advanced audio ports in [Rear View](#) section.

3.7.1. MMX8x4-HT400MC

This model can receive audio from three type of sources:

- HDMI in or TPS in (embedded audio),
- Advanced audio input (AUX analog audio in),
- MIC in.

The output audio ports are:

- HDMI out:** This is the embedded audio of the incoming video signal.
- Advanced audio output (AUX analog audio out):** It contains three types of audio signal (see the picture above). De-embedded audio from one of the incoming video (1x), the advanced analog audio (1x) and the microphone (1x).

3.7.2. MMX8x4-HT420M

This model can receive audio from the sources below:

- **HDMI in or TPS in (embedded audio),**
- **AUX analog audio I/O** (configured as input): This port can be input or output, depending on the configuration. In case of input, the audio will be embedded into the HDMI stream of the port besides (HDMI In 5 or HDMI In 6).

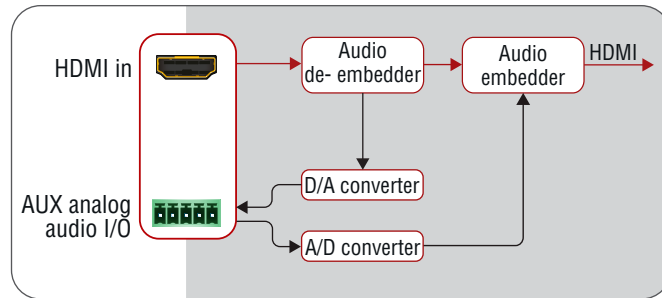

Port diagram of the AUX analog audio I/O

- **Advanced audio input (AUX analog audio in),**
- **MIC in.**

The output audio ports are:

- **HDMI out and TPS out (embedded audio):** This is the embedded audio of the incoming video signal.
- **AUX analog audio I/O** (configured as output): This port can be input or output, depending on the configuration. In case of output, the audio will be de-embedded from the HDMI stream of the port besides (HDMI In 5 or HDMI In 6).
- **Advanced audio output (AUX analog audio out):** It contains three types of audio signal (see the picture above). De-embedded audio from one of the incoming video (1x), the advanced analog audio (1x) and the microphone (1x).

3.7.3. MMX8x8-HDMI-4K-A

This model can receive audio from the sources below:

- **HDMI in (embedded audio),**
- **AUX analog audio I/O** (configured as input): This port can be input or output, depending on the configuration. In case of input, the audio will be embedded into the HDMI stream of the port besides (HDMI In 2, 4, 6, 8 and HDMI Out 2, 4).

The output audio ports are:

- **HDMI out (embedded audio):** This is the embedded audio of the incoming video signal.
- **AUX analog audio I/O** (configured as output): This port can be input or output, depending on the configuration. In case of output, the audio will be de-embedded from the HDMI stream of the port besides (HDMI In 2, 4, 6, 8 and HDMI Out 2,4).

3.7.4. General Audio Settings from Inputs to Outputs

The list below contains the main settings of the audio signal from the source to the destination ports in different cases. These properties can be set in Lightware Device Controller (LDC) software or with LW3 protocol commands.

3.7.4.1. HDMI IN → HDMI OUT

In the first example, the embedded audio of the HDMI signal is transmitted from HDMI in to HDMI out.

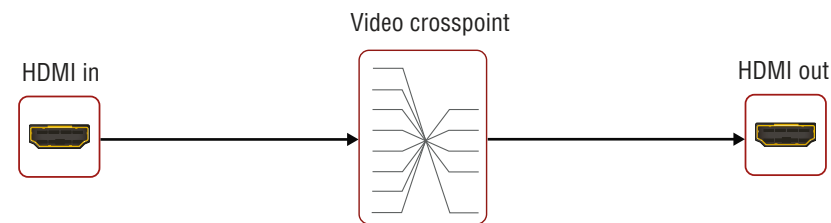

Crosspoint state: Switch the desired video input to the desired output. For more details, see [Crosspoint Operations](#) in LDC chapter, for LW3 command see [Switching and Crosspoint Settings](#) section.

Port status: Unmute the necessary video port. For more details, see [HDMI Input Port Properties](#) and [HDMI and TPS Output Port Properties](#) in LDC chapter, for LW3 command see [Query the Status of Source Port](#) and [Query the Status of Destination Port](#) section.

Input port properties: Set the Audio mode to **HDMI audio passthrough**.

This setting can be found only in I5 and I6 ports of MMX8x4-HT420M model and I2, I4, I6, I8, O2, O4 ports of MMX8x8-HDMI-4K-A model.

HDMI audio passthrough is the default audio mode and this property can not be changed in the other ports.

3.7.4.2. AUX Analog Audio I/O → HDMI OUT

In MMX8x4-HT420M and MMX8x8-HDMI-4K-A models

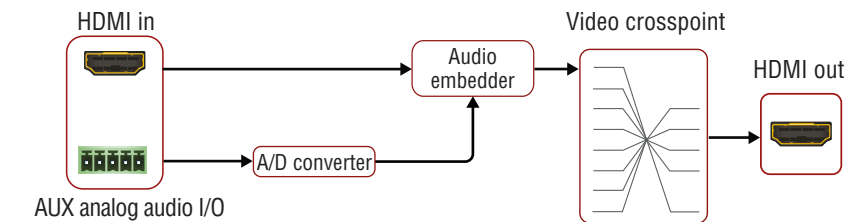

AUX analog audio I/O

Crosspoint state: AUX analog audio I/O belongs to the HDMI port beside. To transmit the audio signal set the appropriate video input and output in the video crosspoint. For more details, see [Crosspoint Operations](#) in LDC chapter, for LW3 command see [Switching and Crosspoint Settings](#) section.

Port status: Check the mute state of the necessary video ports. For more information see [HDMI Input Port Properties](#) and [HDMI and TPS Output Port Properties](#) in LDC chapter, for LW3 command see [Query the Status of Source Port](#) and [Query the Status of Destination Port](#) section.

Input port properties: Set the Audio mode to **Embed from aux audio**, then additional analog audio input settings becomes available. Take care of the proper mute state, volume and gain values. For LW3 command see [AUX Analog Audio I/O Port Settings](#) section.

INFO: Valid video signal is needed for audio transmission, too. The original audio of the HDMI will be replaced with the analog audio.

3.7.4.3. HDMI IN → AUX Analog Audio I/O

In MMX8x4-HT420M and MMX8x8-HDMI-4K-A models

The de-embed audio of the HDMI signal can be transmitted to the AUX analog audio I/O port, which placed beside the HDMI port. No crosspoint setting required.

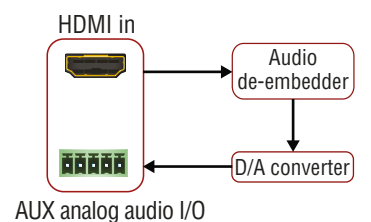

AUX analog audio I/O

Port status: Check the mute state of the necessary video port. For more details, see the [HDMI Input Port Properties](#) in LDC chapter, for LW3 command see [Query the Status of Source Port](#) section.

Input port properties: Set the Audio mode to **Deembed to aux audio**, then additional analog audio input settings becomes available. Take care of the proper mute state and volume value.

3.7.4.4. AUX Analog Audio I/O → AUX Analog Audio I/O

In MMX8x8-HDMI-4K-A model

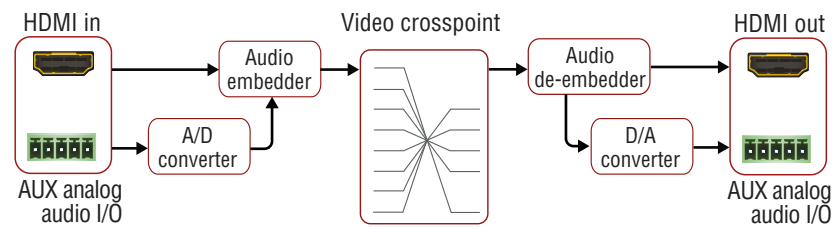

Inputs can be I2, I4, I6 and the outputs can be O2, O4.

Crosspoint state: AUX analog audio I/O belongs to the HDMI port beside. To transmit the audio signal set the appropriate video input and output in the video crosspoint. For more details, see [Crosspoint Operations](#) in LDC chapter, for LW3 command see [Switching and Crosspoint Settings](#) section.

Port status: Check the mute state of the necessary video ports. For more details, see [HDMI Input Port Properties](#) and [HDMI and TPS Output Port Properties](#) in LDC chapter, for LW3 command see [Query the Status of Source Port](#) and [Query the Status of Destination Port](#) section.

Input port properties: Set the Audio mode to **Embed from aux audio**, then analog audio input settings are available. Take care of the proper mute state, volume and gain values. For LW3 command see [AUX Analog Audio I/O Port Settings](#) section.

Output port properties: Set the Audio mode to **Deembed from aux audio**, then analog audio output settings are available. Take care of the proper mute state and volume settings. For LW3 command see [AUX Analog Audio I/O Port Settings](#) section.

3.7.4.5. AUX Analog Audio I/O → Advanced Analog Audio OUT

In MMX8x4-HT400MC and MMX8x4-HT420M models

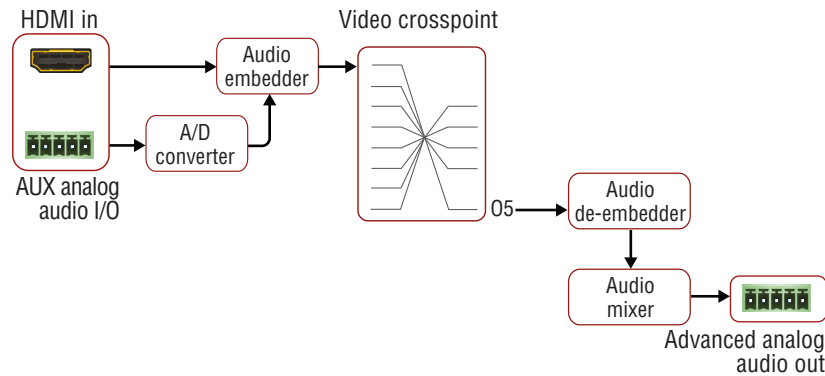

Crosspoint state: AUX analog audio I/O belongs to the HDMI port beside. To transmit the audio signal, set the appropriate video input to O5. For more details about the crosspoint switching, see [Crosspoint Operations](#) in LDC chapter, for LW3 command see [Switching and Crosspoint Settings](#) section.

Port status: Unmute the necessary video input. For more details, see the [HDMI Input Port Properties](#) in LDC chapter, for LW3 command see [Query the Status of Source Port](#) section.

Input port properties: Set the [Analog Audio Input Settings](#) to **Embed from aux audio**, then additional analog audio input settings becomes available. Take care of the proper mute state, volume and gain values. For LW3 command see [AUX Analog Audio I/O Port Settings](#) section.

Audio mixer (advanced audio settings) for I11 audio port: Set the volume, unmute the channel. For more details, see [Embedded or Analog Input Channel](#) in LDC chapter, for LW3 command see [Embedded Audio Input Settings](#) section.

INFO: Choosing the input channel in the drop-down list is equal with switching an input port to O5.

Audio mixer (advanced audio settings) for O6 audio port: Take care of the proper mute state and volume value. For more details, see [Advanced Analog Output Channel](#) in LDC chapter, for LW3 command see [Advanced Analog Audio Output](#) section.

INFO: Valid video signal is needed for audio transmission.

3.7.4.6. MIC IN → Advanced Analog Audio OUT

In MMX8x4-HT400MC and MMX8x4-HT420M models

Audio mixer (advanced audio settings) for I9 audio port: Set the volume and the gain, unmute the channel. See more details in [Installation Guide for Connecting a Microphone](#).

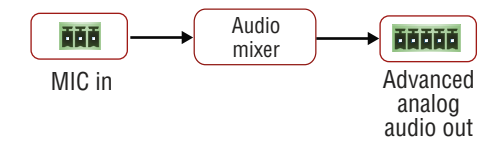

Audio mixer (advanced audio settings) for O6 audio port: Take care of the proper mute state and volume value. For more details, see [Advanced Analog Output Channel](#) in LDC chapter, for LW3 command see [Advanced Analog Audio Output](#) section.

INFO: Valid video signal is **not** needed for audio transmission. No crosspoint setting required.

3.7.4.7. Advanced Analog Audio IN → Advanced Analog Audio OUT

In MMX8x4-HT400MC and MMX8x4-HT420M models

Audio mixer (advanced audio settings) for I10 audio port: Set the volume and the gain, unmute the channel. For more details, see [Advanced Analog Input Channel](#) in LDC chapter, for LW3 command see [Advanced Analog Audio Input](#) section.

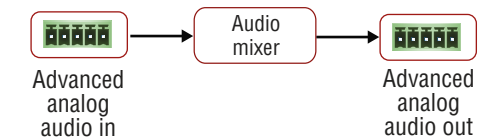

Audio mixer (advanced audio settings) for O6 audio port: Take care of the proper mute state and volume value. For more details, see [Advanced Analog Output Channel](#) in LDC chapter, for LW3 command see [Advanced Analog Audio Output](#) section.

INFO: Valid video signal is **not** needed for audio transmission. No crosspoint setting required.

3.7.4.8. HDMI IN → Advanced Analog Audio OUT

In MMX8x4-HT400MC and MMX8x4-HT420M models

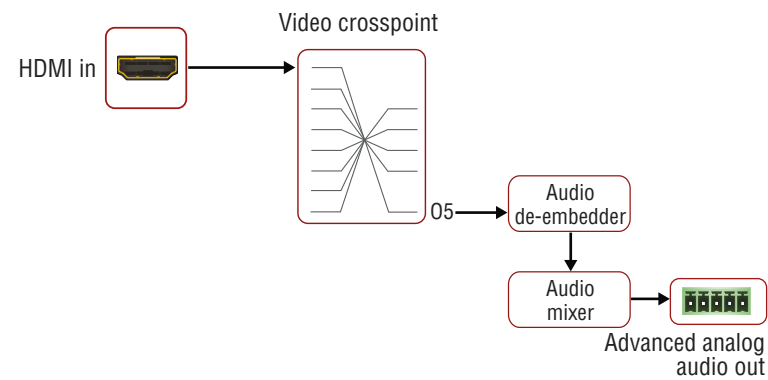

Crosspoint state: Switch the desired video input to O5. For more details, see [Crosspoint Operations](#) in LDC chapter, for LW3 command see [Switching and Crosspoint Settings](#) section.

Port status: Unmute the necessary video port. For more details, see the [HDMI Input Port Properties](#) in LDC chapter, for LW3 command see [Query the Status of Source Port](#) section.

Input port properties: Set the Audio mode to **HDMI audio passthrough**.

This setting can be found only in I5 and I6 ports of MMX8x4-HT420M model. HDMI audio passthrough is the default audio mode in the other ports and this property can not be changed.

Audio mixer (advanced audio settings) for I11 audio port: Set the volume and the gain, unmute the channel. For more details, see [Embedded or Analog Input Channel](#) in LDC chapter, for LW3 command see [Embedded Audio Input Settings](#) section.

INFO: Choosing the input channel in the drop-down list is equal with switching an input port to O5.

Audio mixer (advanced audio settings) for O6 audio port: Take care of the proper mute state and volume value. For more details, see [Advanced Analog Output Channel](#) in LDC chapter, for LW3 command see [Advanced Analog Audio Output](#) section.

3.8. Control Features

The devices can be controlled over Ethernet, USB, and RS-232 ports as well. The following sections are about to describe the available features and settings by these interfaces.

3.8.1. Ethernet Interface

The device can be controlled via Ethernet port (RJ45 connector). This interface supports any third-party system controller with LW2/LW3 command protocol. The interface can be used to configure the device with Lightware Device Controller and establish the connection to Lightware Device Updater software and perform firmware upgrade.

Serial and infra messages can be sent and received via Control Ethernet port (See more details about it in [Serial Interface](#) and [Infra Interface](#) section).

INFO: In MMX8x4-HT400MC and MMX8x4-HT420M models, TPS lines do not transmit Ethernet signal, but the matrix is able to receive TCP/IP commands via Control Ethernet port. In case of MMX8x4-HT420M model Ethernet signal transmission is possible via TPS lines, but it needed physical link between the boards. For more details see the the next section.

Third-party control via MMX8x4-HT420M

MMX8x4-HT420M model contains RJ45 connector to supply Ethernet communication for the TPS lines. Ethernet commands can be transmitted on the TPS input and output ports if there is a physical link between the motherboard and the input or the output board.

Ethernet Link to TPS I/O labeled connector on the I/O card is connected to the switch directly.

The other TPS input and output ports are connected to the switch via a converter. (This converter is able to separate the incoming TPS stream into video, audio, RS-232, power and Ethernet signal. These signals are packed into the TPS signal by the converter, as well.)

INFO: The LAN can be enabled or disabled for every single TPS port with Lightware Device Controller (LDC) software or LW3 protocol command.

Create a link towards the TPS input ports by connecting a patch cable between the two RJ45 connectors (**Ethernet Link to TPS inputs** and **TPS inputs Ethernet**).

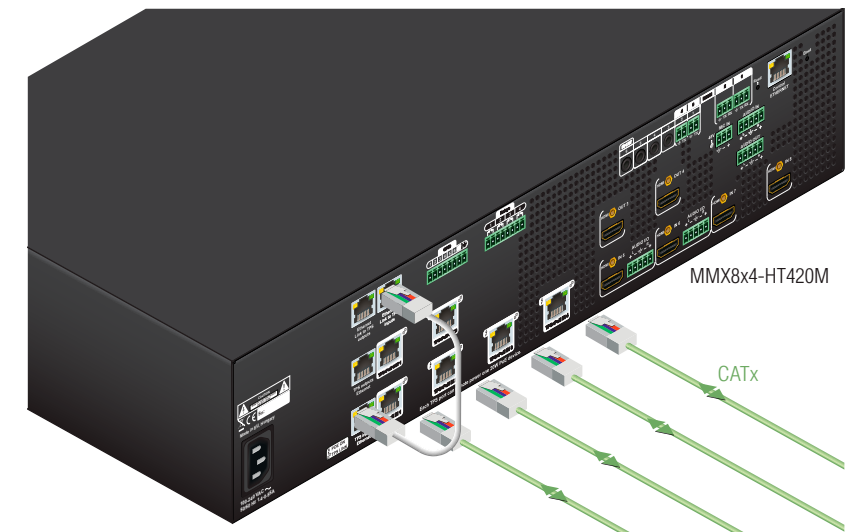

Ethernet Link to TPS inputs

Create a link towards the TPS output ports by connecting a patch cable between the two RJ45 connectors (**Ethernet Link to TPS outputs** and **TPS outputs Ethernet**):

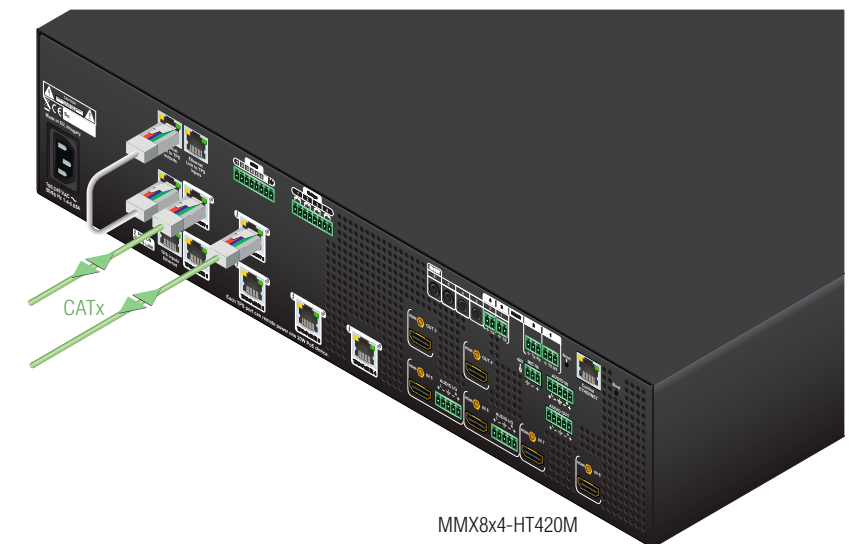

Ethernet Link to TPS outputs

Ethernet Interface - Example

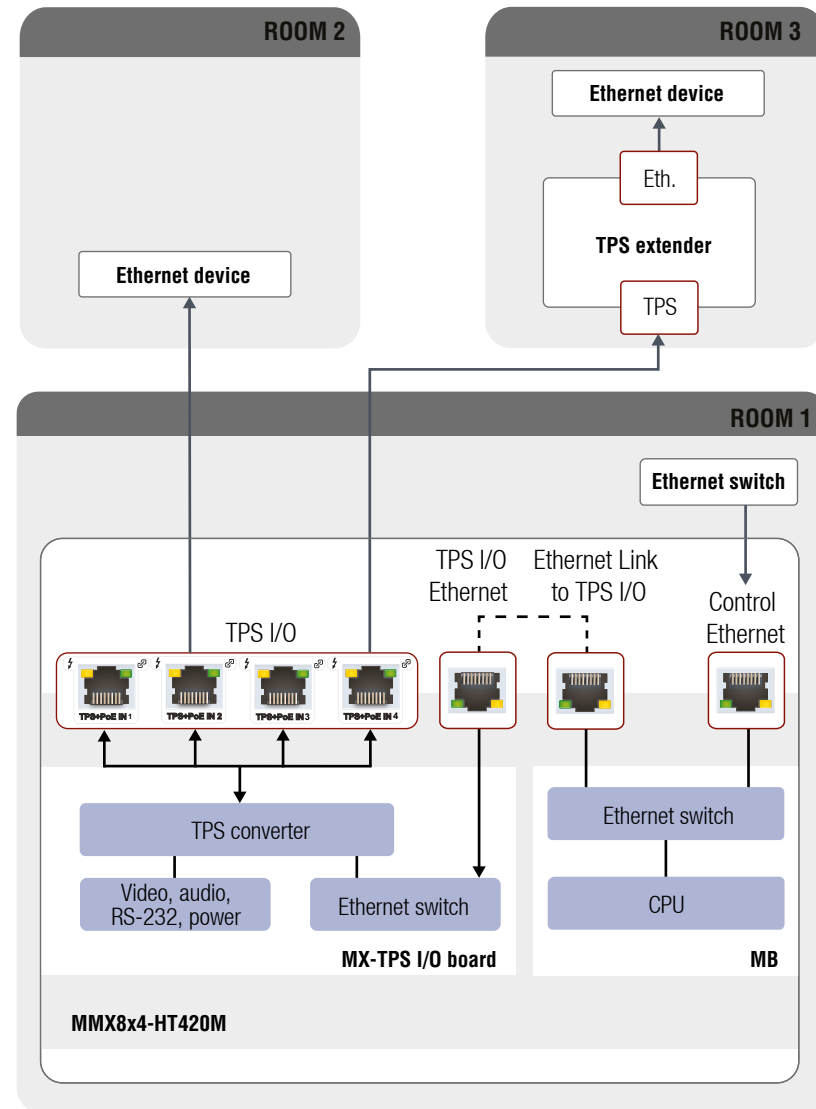

Ethernet and TPS Connectors for LAN

The concept

In the room 1. the Matrix reaches the LAN by connecting the **Control Ethernet** port to the Ethernet switch.

Creating a link between the RJ45 connectors labeled **Ethernet Link to TPS inputs** and **TPS inputs Ethernet** makes possible to support TPS input ports (I1-4) with Ethernet.

In the room 2. a third-party Ethernet device connects to the TPS input port (I2). In this case, instead of TPS data transmission the TPS connection provides only Ethernet connection to the LAN.

In the room 3. the TPS extender connects to the TPS input port (I4) of the Matrix. Besides the TPS data transmission, the TPS extender provides connection to the LAN for e.g. a laptop.

Settings

Matrix: TPS modes in TPS input ports (I2, I4) can be set Auto. ETH Link TPS In (P4), TPS IN2 (P6), TPS IN4 (P8) can be enabled.

3.8.2. Infra Interface

Summary of Infra Ports

	2-pole Phoenix		TRS (3.5mm Jack)	
	Nr.	Data transmission	Nr.	Data transmission
MMX8x4-HT400MC	2x	Tx	2x	Tx
MMX8x4-HT420M	2x	Tx	4x	Tx
MMX8x8-HDMI-4K-A	2x	Tx	2x	Tx

INFO: The 2-pole Phoenix connector can be both infra or serial output. For infra data transmission the destination TCP port numbers are **9001** and **9002**. No setting required for configuring the interface, it works automatically.

ATTENTION! The IR signal cannot be routed from an IR port to another IR port.

Technical background

The Infrared signal transmission is similar to the serial data communication. The matrix contains dedicated IR output where IR code sending is possible. The matrix can receive IR signal via the Control Ethernet port. The Infrared signal is in pronto hex format.

Getting IR codes

Getting IR code is possible from two sources:

- Download a code which belongs to your controlled device from a web database from the Internet. The downloaded codes are mostly in **little-endian format**.
- Learn IR code (see the details below).

Learn IR code

Step 1. Connect a Lightware device which has IR detector unit (e.g. UMX-TPS-140) with a terminal program.

Step 2. Push the proper button of the remote control to scan the IR codes in hex format.

Step 3. Remove all the non-hexadecimal characters (e.g. spaces, **h** characters etc.) from the code.

INFO: The pronto hex code which learned by a Lightware device is **big-endian** format.

Sending Big-endian format pronto hex codes

With LW3 protocol command

Step 1. Connect the **6107** port of the matrix.

Step 2. Use LW3 protocol command to send the pronto hex code:

▶ `CALL /MEDIA/IR/D1:sendProntoHexBigEndian(<prontohex>)`

INFO: The maximum length of the code can be 765 characters (765 bytes). For more details about the accepted IR code formats see [Sending Pronto Hex Codes in Big-endian Format via IR Port](#) section.

Sending Little-endian format pronto hex codes

With Lightware Device Controller software

Step 1. Connect the **6107** port of the matrix and open the LDC software.

Step 2. Choose the desired IR output in the control menu, on the infra tab.

Step 3. Copy the IR code into the **Send Pronto Hex** entry field and click the **Send** button.

INFO: The maximum length of the code can be 765 characters (765 bytes). For more details about the accepted IR code formats see [Sending Pronto Hex Codes in Little-endian Format via IR Port](#) section.

With LW3 protocol command

Step 1. Connect the **6107** port of the matrix.

Step 2. Use LW3 protocol command to send the pronto hex code:

▶ `CALL /MEDIA/IR/D1:sendProntoHex(<prontohex>)`

INFO: The maximum length of the code can be 765 characters (765 bytes). For more details about the accepted IR code formats see [Sending Pronto Hex Codes in Little-endian Format via IR Port](#) section.

With Event Manager

Step 1. Connect the **6107** port of the matrix.

Step 2. Create an event in Event manager. After setting any condition, set the action:

Category: **Infra**; Expression: **Send pronto hex**; Port: **D1-D6**; Pronto hex: **Insert the pronto hex code**.

INFO: The maximum length of the code can be 184 characters (184 bytes).

Sending IR code in Command Injection mode

When the data transmission is enabled, the output port works in command injection mode. The IR data (in pronto hex format) is transferred between the LAN port and the IR port. Separate user-configurable TCP/IP port numbers are defined for IR output ports for this purpose, see [Factory Default Settings](#) section. The settings are available in the LDC software, see [Infra Tab](#) section.

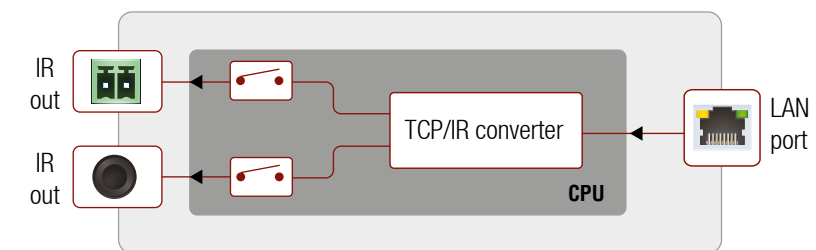

Port Diagram of IR Interface

IR Interface - Example

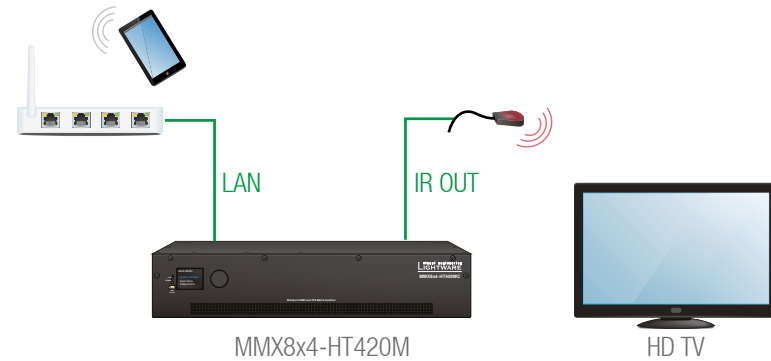

The concept

IR command ('Power on') can be sent from the smart phone with IR - TCP/IP converter application over WI-FI. The TCP/IP message is forwarded to the matrix via Control Ethernet port. The Matrix converts the TCP message to IR format and transmits the IR signal to the IR output port (e.g. 9001). The connected IR emitter sends the IR command ('Power on') to the TV.

Settings

Matrix: Control Ethernet port (P2) can be enabled. Check the IR port number (default value is 9001). The port can be enabled (operation mode is always command injection).

3.8.3. Serial Interface

Technical Background

Serial data communication can be established via the local RS-232 port (Phoenix connector), TTL serial port (Phoenix connector) and over the TPS lines. The RS-232 ports – which are connected to the microcontroller – can be configured separately.

INFO: The 2-pole Phoenix connector can both infra and serial output depending on the sent message protocol. No setting required for configuring the interface, it works automatically.

Summary of Serial Ports

	Local						Remote					
	RS-232			TTL serial			TPS			Control Ethernet		
	Connector type	Nr. of connectors	Data transmission	Connector type	Nr. of connectors	Data transmission	Connector type	Nr. of connectors	Data transmission	Connector type	Nr. of connectors	Data transmission
MMX8x4-HT400MC	3-pole Phoenix	2x	Tx, Rx	2-pole Phoenix	2x	Tx	RJ45	4x	Tx, Rx	RJ45	1x	Tx, Rx
MMX8x4-HT420M	3-pole Phoenix	2x	Tx, Rx	2-pole Phoenix	2x	Tx	RJ45	6x	Tx, Rx	RJ45	1x	Tx, Rx
MMX8x8-HDMI-4K-A	3-pole Phoenix	2x	Tx, Rx	2-pole Phoenix	2x	Tx	-	-	-	RJ45	1x	Tx, Rx

Summary of Serial Operation Modes

The RS-232 port can be switched to **Control mode**, **Command Injection mode**, or can be **Disconnected**; see the table and the figure below.

	Disconnected	Control	Command Injection (CI)
RS-232	✓	✓	✓
TTL serial	-	-	✓
TPS	✓	✓	✓

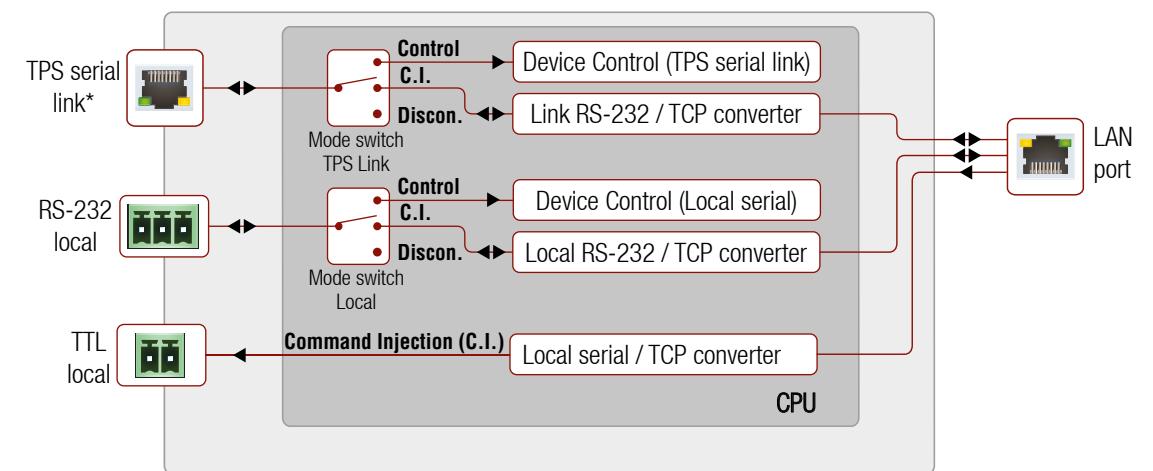

The block diagram of the Serial interface

*In MMX8x4-HT400MC and MMX8x4-HT420M models.

Disconnect

This mode is for control the third-party device from the Matrix. In this case, the Matrix does not receive RS-232 messages but sends serial data from the CPU.



The concept

Powering on the HDTV via RS-232 message from the matrix.

Settings

The **Matrix** can send RS-232 commands over the local RS-232 ports (P1 or P2) to the **HDTV**. You can see the details about serial message sending in the [Message Sending via RS-232 Serial Port](#) section.

Control mode

The incoming data from the given port is processed and interpreted by the CPU. The mode allows to control the matrix directly. LW2 or LW3 protocol commands are accepted – depending on the current port setting.

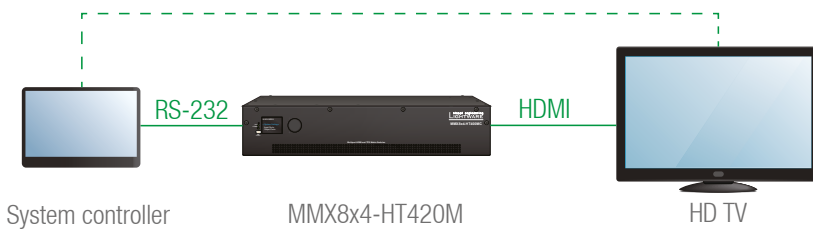

Application example of control mode

The concept

The **System controller** sends commands to the **Matrix**, which set the video and audio properties. The **Matrix** executes the commands and transmits the video signal to the sink.

Settings

The **System controller** can send LW2 or LW3 commands to the local RS-232 port (P1 or P2) of the **Matrix**. In control mode, the commands are processed in the device. This function makes possible to set the crosspoint or a volume level etc.

Command injection mode

In this mode, the matrix works as an RS-232–Ethernet bidirectional converter. The Ethernet packets are converted to RS-232 data and vice versa. Unique TCP/IP port numbers are defined for the serial ports for this purpose.

E.g. the default Command Injection port number of the local RS 232 port (P1) is 8001. If a command is coming from the LAN interface which is address to the port no. 8001, it will be transmitted to the Tx pin of the local RS-232 port. That also works in the opposite direction.

In MMX8x4-HT420M model, the method is the same on the serial interface of the TPS port. Sending message from a remote TPS device via TPS port to the RS-232 port of the matrix is also possible, but connecting the Ethernet link to the TPS port with patch cables is needed.

Application example of command injection mode

See the RS-232 settings in [Factory Default Settings](#) section.



The concept

The System controller can send commands (input/output switching, control functions, etc.) to the matrix and is able to remote control the HDTV via RS-232.

Settings

Matrix: The RS-232 interface of the TPS OUTPUT 1 (P4) is in Command Injection (CI) mode. Set the further parameters (Baud rate, Data bits, etc.) in accordance with the specifications of the television.

All settings are available in the LDC software, see [RS-232 Tab](#) section.

TTL Serial

The 2-pole Phoenix connector can be both infra or serial output. For TTL data transmission the destination port numbers are **8003** and **8004**. No setting required for configuring the interface, it works automatically.

	TTL*	RS-232
Logic low level	0 .. 0.25V	3 V .. 15 V
Logic high level	4.75 .. 5.0V	-15 V .. -3 V

Serial Output Voltage Levels (TTL and RS-232)

*Using a receiver with at least 1k impedance to any voltage between 0V and 5V to get the voltages.

3.8.4. GPIO Interface

INFO: Only the MMX8x4-HT420M model has GPIO connector.

The GPIO (General Purpose Input/Output) port is a multifunctional input/output interface to control the transmitter or third-party devices and peripherals. You can establish connection between the controller/controllable device and the transmitter by the 8-pole Phoenix connector. Six pin's direction is configurable independently based on needs of the application.

GPIO Options - Example

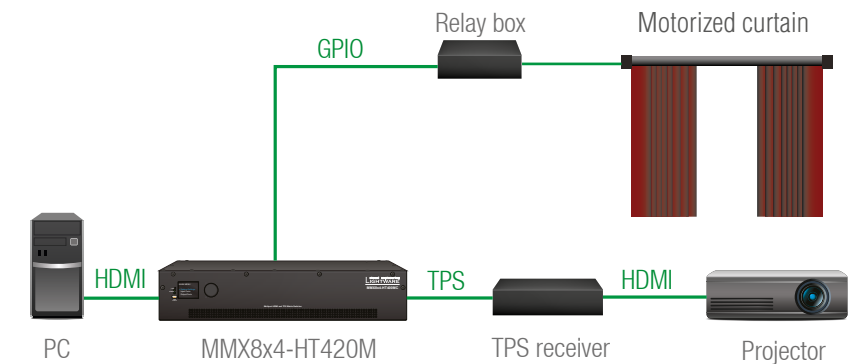

The Concept

Motorized curtain is pulled back by **Relay box** when signal received from the PC over the HDMI input. Relay box is controlled by the GPIO port.

Settings

Step 1. Create an event in Event manager: when signal is present on Input 5 (I5) then set GPIO pins to low level for Relay box opening.

Step 2. Also create another event when signal is not present on Input 5 (I5) then set GPIO pins to high level for Relay box closing.

When the PC starts to play the video presentation, the signal is received over the HDMI input so GPIO pins send signal to Relay box to open which results pulling back the curtains.

When the presentation is ended, signal ceases on the HDMI input, so GPIO pins send signal to Relay box to close which results drawing the curtains

ATTENTION! Please always check the electrical parameters of the devices what you want to control. The maximum current of one GPIO pin is 30 mA, the maximum total current for the seven pins is 180 mA.

See the LDC settings for GPIO port in the [GPIO Tab](#) section. See also the details about the Event Manager settings in the [Event Manager](#) section.

3.8.5. Relay Interface

INFO: Only the MMX8x4-HT420M model has relay connector.

The matrix contains four relay modules which can be accessed by an 8-pole Phoenix connector. The relays can be controlled by Lightware protocol commands (LW3) and Event manager actions can be assigned to the port.

ATTENTION! The device built with normally open (N.O.) contact relays which means when the unit is not powered (DC plug is disconnected), the relays will open.

Application of Relays - Example

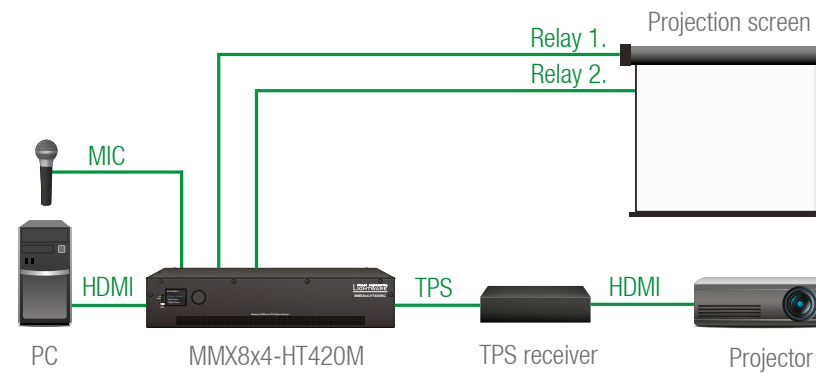

The Concept

Projection screen is rolled down by relay when the audio signal is present on the microphone input of the Matrix. When HDMI signal is not present on the input, the projection screen is rolled up.

Settings of the Matrix

Step 1. Create an event in Event manager: when signal is present on the microphone input (I9) then set Relay 1. (P1) to be closed.

Condition (on Advanced tab):
/MEDIA/AUDIO/I9.IndicatorNominal=true

Action (on Wizard tab):
Category: **Relay**, Expression: **Close contact on relay**, Port: **P1**

Step 2. Create another event when signal is not present on Input 5 (I5) then set the Relay 2. (P2) to be closed.

The lecturer can roll down the projection screen by talking to the microphone. It means, the audio signal is present on the microphone input (signal peak indicator becomes true), the Relay 1. (P1) closes.

When the presentation is finished, signal ceases on the HDMI input, so

the Relay 2. (P2) closes and projection screen returns to its enclosure.

See the LDC settings for Relay port in the [Relay Tab](#) section. See also the details about the Event Manager settings in the [Event Manager](#) section.

3.8.6. USB Control Interface

The device can be controlled over front panel USB port (mini B-type connector). This interface supports LW3 protocol. The interface can be used to establish a connection to Lightware Device Controller software.

INFO: USB control operates locally, USB data is not transmitted.

4

Operation

This chapter is about the powering and operating of the device describing the functions which are available by the front/rear controls:

- ▶ [POWERING ON](#)
- ▶ [STATUS LEDs](#)
- ▶ [FRONT PANEL LCD MENU OPERATIONS](#)
- ▶ [FRONT PANEL BUTTON OPERATIONS](#)
- ▶ [FRONT PANEL OPERATIONS – QUICK SUMMARY](#)

4.1. Powering On

Connect the power cord to the AC input connector; the matrix is immediately powered on. After the self-test (about 30 seconds), the last configuration is loaded automatically.

INFO: The router has an internal emergency memory that stores all current settings and tie configurations. This memory is independent from presets and invisible for the user. This built-in feature helps the system to be ready immediately in case of power failure or accidental power down.

4.2. Status LEDs

LIVE			FRONT
	green	blinking slow	The unit is on and operates properly.
	green	blinking fast	The unit is in bootloader mode.
		off	The matrix is out of operation.
POWER			FRONT
	green	on	Power LED indicates that the unit is powered on.
		off	The matrix unit is NOT powered or out of operation.
48V*			REAR
	red	on	Phantom power is turned on.
		off	Phantom power is turned off.

MMX8x4-HT400MC and MMX8x4-HT420M models

TPS LEDs				REAR
			off	Remote power (PoE) is inactive, device is powered locally.
		amber	on	Remote power is active.
			off	No TPS link between the transmitter and receiver.
		green	blinking	Device is in low power mode or Ethernet fallback mode.
		green	on	TPS signal is present.

4.3. Front Panel LCD Menu Operations

The front panel has a color LCD that shows the most important settings and parameters structured in a menu. The jog dial control knob can be used to navigate between the menu items or change the value of a parameter. The knob can be pressed to enter a menu or edit/set a parameter.

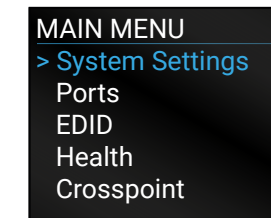

Menu navigation & change parameter

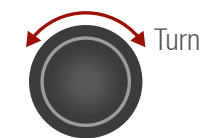

Menu selection & set parameter

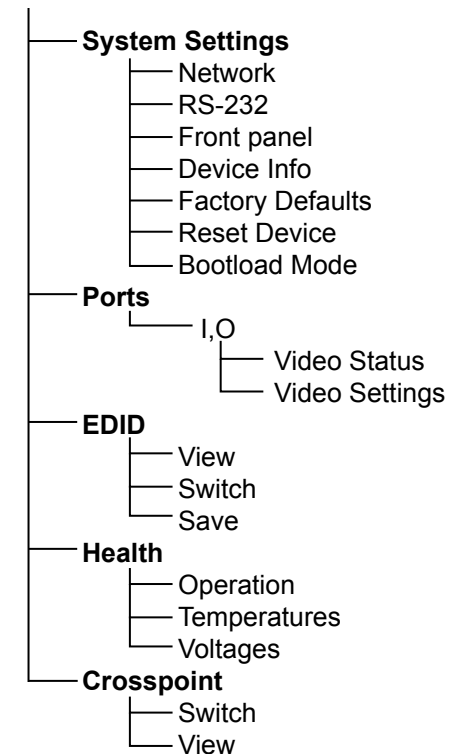

Parameter Selection

The blue colored line means the selected menu/parameter, the green one means the current setting.

TIPS AND TRICKS: The faster you rotate the jog dial, the faster the parameter list is scrolled.

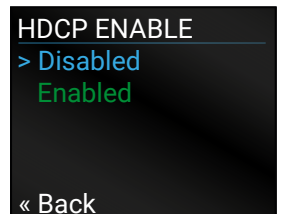

4.3.1. System Settings Menu

Network Submenu

The parameters of the network connection can be set in this submenu. IP, Subnet, Gateway and MAC parameters show the current settings. If the DHCP option is disabled, three more parameters are listed which can be set for a static IP address:

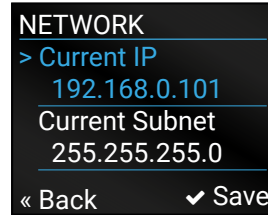

- Static IP,
- Static Subnet,
- Static Gateway.

ATTENTION! If you change the network settings, always press the Save option under Network menu (not only in the submenu of the parameter) to apply the new settings.

RS-232 Submenu

When entering the submenu the available serial ports are listed. Select the desired port and enter to see the settings.



Adjustable parameters of the serial ports:

- Mode (Disconnect/ Control/ Command injection),
- Baud Rate* (4800/ 7200/ 9600/ 14400/ 19200/ 38400/ 57600/ 115200)
- Protocol (LW2/ LW3).

*At Mixed IR /TTL serial port, only this setting is available.

Front Panel Submenu

The following front panel-related parameters can be set in this submenu:

- Display Backlight (1-10)

The brightness of the LCD can be set from 1 to 10 on a scale.

- Rotary Direction (CW Down/ CCW Down)

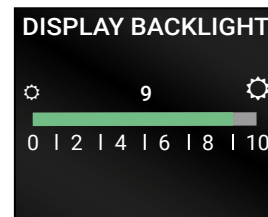

Device Info Submenu

In this submenu you can check basic information about the transmitter unit:

- Serial number
- Hardware Version
- Firmware Version

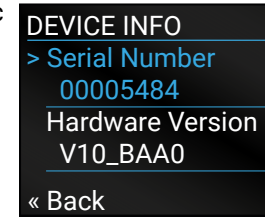

Factory Defaults Submenu

Factory default settings will be restored by choosing **Yes**.

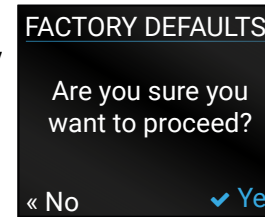

Reset Device Submenu

There is a possibility to reset the device.

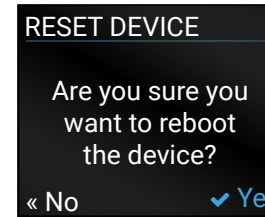

Bootload Mode Submenu

Special function for entering the bootload mode.

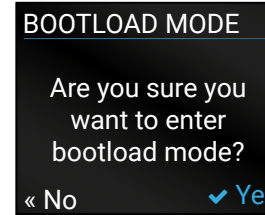

4.3.2. Ports Menu

When entering the menu the available video input and output ports are listed. The icons display information about the port and the video signal (see below table). Select the desired port and enter to see the submenu.

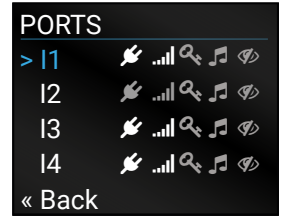

Grey icon	Description	White icon	Description
	Source/sink is not connected		Source/sink is connected
	No audio signal in the video stream		Audio is embedded in the video stream
	Signal is not present		Signal is present
	Signal is not encrypted with HDCP		Signal is encrypted with HDCP
	The port is unmuted		The port is muted

Video Status Submenu for Input Ports

The most important properties of the chosen input port can be checked in this submenu:

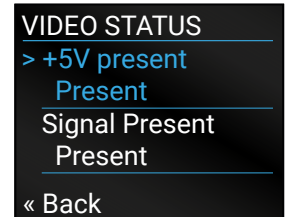

Parameter	Input port
+5V present	Present/ Not present
Signal Present	Present/ Not present/Unknown
HDCP Status	Encrypted/ Not encrypted/Unknown
Embedded Audio	Present/ Not present/Unknown
Pixel Clock (MHz)	No signal/ [x] MHz
Active Resolution	Unknown/ No signal/ [x]x[y][i\ p][f]
Total Resolution	Unknown/ No signal/ [x]x[y]

Video Settings Submenu for Input Ports

- HDCP Enable (Disabled / Enabled)

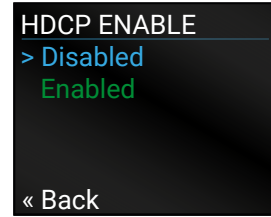
**Video Status Submenu for Output Ports**

The most important properties of the chosen output port can be checked in this submenu:

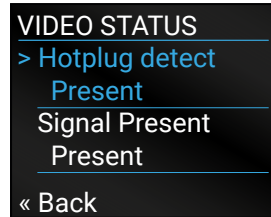

Parameter	HDMI OUTPUT
Hotplug detect	Present/ Not present
Signal Present	Present/ Not present/Unknown
HDCP Status	Encrypted/ Not encrypted/Unknown
Embedded Audio	Present/ Not present/Unknown
Pixel Clock (MHz)	No signal [x] MHz
Active Resolution	Unknown/ No signal [x]x[y][i\ p][f]
Total Resolution	Unknown/ No signal/ [x]x[y]

Video Settings Submenu for Output Ports

- Signal type (Auto / DVI / HDMI)
- +5V Enable (Always on / Always off / Auto)
- HDCP Mode (Auto / Always on)

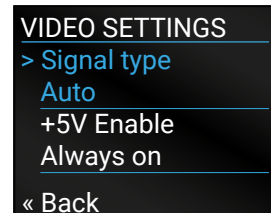
**Audio Settings Submenu for Output Port**

INFO: O5 port of MMX8x4-HT400MC and MMX8x4-HT420M models contains the audio settings. It refers to the advanced audio port.

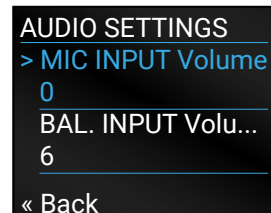

Volume settings are available in this submenu:

- MIC INPUT Volume (from -80 to 10)
- BAL. INPUT Volume (from -80 to 10)
- BAL. OUTPUT Volume (from -80 to 10)

4.3.3. EDID Menu

Advanced EDID Management is available in the front panel LCD menu which allows to view an EDID, switch, or save it to the User EDID memory. See more information about EDID technology in [EDID Management](#). The EDID memory structure of the device can be found [Sources and Destinations](#) chapter.

View Submenu

Select the desired EDID memory block: **Factory EDIDs**, **Last Attached EDIDs**, **User EDIDs**, or **Emulated EDIDs**. Select the **Name** item and press the knob. Use the jog dial to step between the EDIDs. The following information can be checked:

- Preferred Resolution
- Monitor Name
- Audio Info

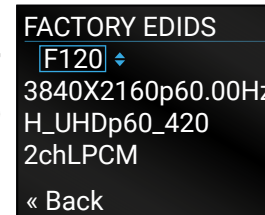
**Switch Submenu**

The submenu looks similar as the View submenu but in this case, the Destination is also listed. To change an EDID do the followings:

- Step 1.** Navigate to the **EDID/Switch** submenu.
- Step 2.** Select the **Name** item and press the knob. Use the jog dial to select the desired **EDID** (Factory EDIDs, User EDIDs, or Dynamic EDIDs) and press the knob.
- Step 3.** Select the **Destination** item and press the knob. Use the jog dial to select the desired **EDID memory** (Emulated EDIDs, All) and press the knob.

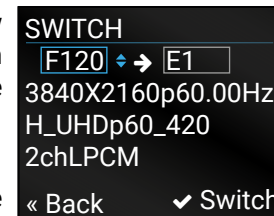

- Step 4.** Navigate to the **Switch** option and press the knob.

Save Submenu

The EDID of a connected sink can be saved to the User EDID memory as follows:

Step 1. Navigate to the EDID/Save submenu.

Step 2. Select the **Name** item and press the knob. Use the jog dial to select the desired **EDID** (Dynamic EDID) and press the knob.

Step 3. Select the **Destination** item and press the knob. Use the jog dial to select the desired **EDID memory** (User EDIDs) and press the knob.

Step 4. Navigate to the **Save** option and press the knob.

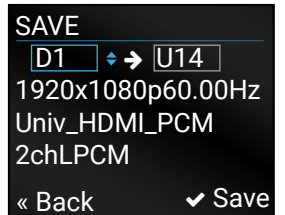
**4.3.4. Health Menu****Operation Submenu**

The following information is displayed about the transmitter unit in this menu:

- Uptime: the elapsed time since the last booting.
- Operation time: displays the summary of the operation hours.

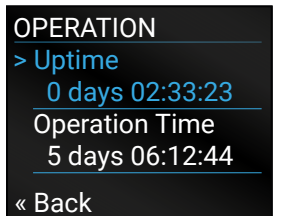
**Temperatures Submenu**

This submenu gives a feedback about the current temperatures of the internal parts in the unit:

- CPU / System / Air intake / Crosspoint / Power Supply

Voltages Submenu

The following information is displayed in Voltages Submenu:

- Main 5V
- Main 3.3V

4.3.5. Crosspoint Menu

Crosspoint settings can be viewed and switched in the front panel LCD menu.

Switch Submenu

In the left column, the inputs are listed and the outputs are displayed in the right column. If the frame of the column is blue, it means this is active, so navigation and selection with jog dial is possible.

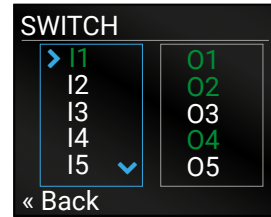

Step 1. Navigate to the **Crosspoint/Switch** submenu.

Step 2. Use the jog dial to select the desired **Input port** item and press the knob.

Step 3. Use the jog dial to select the desired **Output port** item and press the knob. Crosspoint switching performed immediately.

Green color shows the outputs which have already connected. For disconnect the output, select it and press the knob (text color becomes white).

INFO: When the selected port is locked, the switching will not perform.

View Submenu

In the left column, all the inputs and outputs are listed. The ports connected to the selected one (green colored) are listed in the right column.

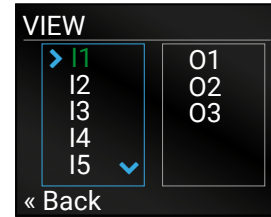

TIPS AND TRICKS: The appearing arrows show there is more information to display; scroll with the jog dial.

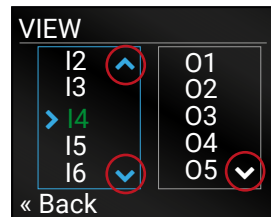

4.4. Front Panel Button Operations

ATTENTION! Front panel buttons are available only in MMX8x8-HDMI-4K-A model.

4.4.1. Control Lock

DEFINITION: The Control Lock means to disable the front panel buttons and the jog dial.

While the front panel buttons are disabled the RS-232 / RS-422, USB and Ethernet control is still enabled. If the button is not illuminated, front panel button operations are enabled. If it illuminates red continuously, front panel operations are inhibited (including LCD menu).

Press and hold the **Control lock** button for 3 seconds to toggle the control lock state.

4.4.2. Take / Autotake Modes

The router has two different switching modes: **Take** and **Autotake**. If the **Take / Auto** button is unlit, **Take** mode is active. When the **Take / Auto** button continuously lights green, **Autotake** mode is selected.

Press and hold the **Take** button for three seconds to toggle between **Take** and **Autotake** modes.

Take Mode

DEFINITION: The **Take** mode allows the user to connect or disconnect multiple outputs to an input at once but the layout must be confirmed (executed) by the **Take** button as a final step.



The commands are only realized when the **Take** button is pressed. If no button is pressed for two seconds, all preselected actions (which were not realized with the pressing **Take**) will be ignored, and the router returns to its idle state.

Autotake Mode

DEFINITION: The **Autotake** mode means the switching actions are executed immediately (without user confirmation).



The switching occurs immediately upon pressing one of the input selector buttons. This mode is useful when time delay is not allowed between multiple switching.

4.4.3. View Crosspoint State

The current switching status can be checked on the front panel by using the front panel buttons. The crosspoint state is displayed slightly different in **Take** or **Autotake** modes because of the different switching methods.

INFO: View mode does not mean, that the router has to be switched in different modes, viewing and switching can be done after each other, without pressing any special buttons.

View Current State in Take Mode

If the router is in **Take** mode, the user can verify both input and output connections. In **Take** mode no accidental change can be done unless **Take** button is pressed.



Press and release a **source button**. Now the selected source button and all destination buttons which are currently connected to the selected source will light up. This informative display will remain active for three seconds, then all buttons turn to dark.

Sample drawing shows that Input 1 is currently connected to the Output 2, 3, and 5 ports.

If every source, destination, and **Take** buttons are unlit (the unit is in **Take** mode, and no input was selected in the last 3 seconds), press and release a **destination button** to see its current state. Now the source button, which is connected to the selected destination, will light up.

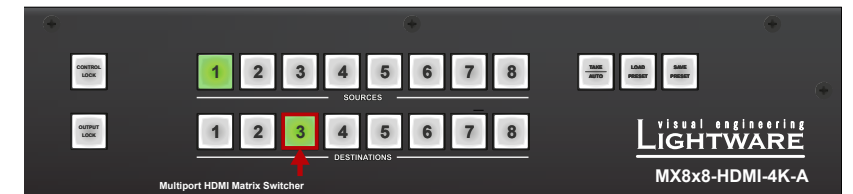

Sample drawing shows that Output 3 is connected to the Input 1.

View Current State in Autotake Mode

In **Autotake** mode only states of destinations can be viewed.

Press and release the required **destination button**. Now the source button, which is connected to the selected destination, will light up.



4.4.4. Switching Operations

Switching in Take Mode



Take mode allows the user to connect or disconnect multiple outputs to an input at once. This mode is useful when the time delay is not allowed between multiple switching. The commands are only realized when the **Take** button is pressed.

Step 1. First, press and release the desired **source button**. The pressed source button and all destination buttons which are currently connected to the source lights up.

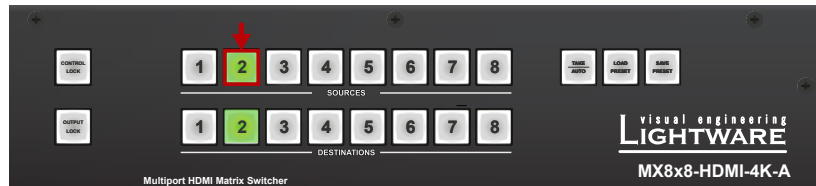

Step 2. Press and release the desired **destination buttons** which have to be (dis)connected to/from the selected source. The preselected destination buttons will blink. If no button is pressed for three seconds, the buttons will turn to dark.



Step 3. Press and release **Take** button; the selected input is switched to the selected output(s).



Switching in Autotake Mode



Autotake mode is useful when immediate actions must be done or fast switching is needed between sources on a particular destination. In this mode switching occurs immediately upon pressing one of the input selector buttons.

Step 1. Press and release the desired **destination button**. The pressed destination button and the actually connected source button light up green. If no source is connected (the output is muted) no source button will light up.



Step 2. Press and release the desired **source button**. The switch action will be executed immediately. Switching between sources to the selected destination can be done directly.



4.4.5. Output Lock

ATTENTION! However, the front panel buttons allow to lock only the output ports, the input ports can also be locked by using Lightware Device Controller software (see [HDMI and TPS Output Port Properties](#) section) or sending LW3 protocol command (see [Lock an Output Port](#) section).

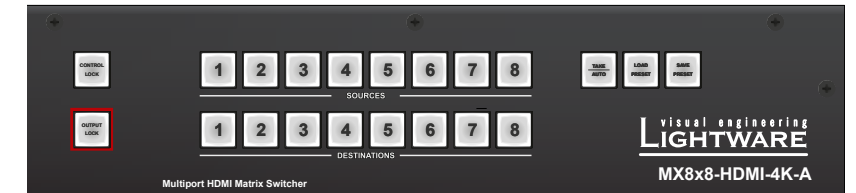

Using Lightware routers it is possible to lock a destination. This feature prevents an accidental switching to the locked destination in case of an important signal. Locking a destination means that no input selection or muting action can be executed on that particular destination.

Destinations can be independently locked or unlocked. Locking a destination does not affect other destinations.

Output Lock in Take Mode

Step 1. Press and release the **Output Lock** button; it starts to blink and all the buttons of any locked destinations light up (view state).



Step 2. Press and release a **destination button**; it starts to blink (more destinations can be selected sequentially).



Step 3. Press and release **Take** button. The selected destinations are now locked.



Output Lock in Autotake Mode

Step 1. Press and release the required **destination button**. Now the selected destination button and the currently configured source button light up (view mode).



Step 2. Press and release the **Output Lock** button; it lights up in red, and lock function is activated at once. No source can be changed at the locked destination.



4.4.6. Control Lock

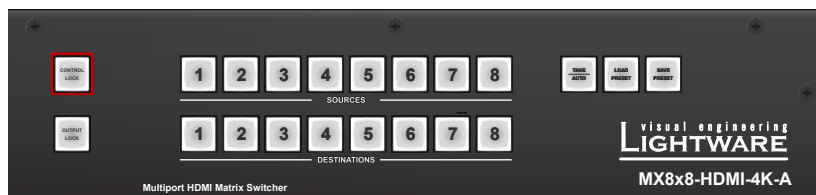

Front panel button operation can be enabled or disabled using **Control Lock** button, while the remote control is still enabled. If the button is unlit, front panel button operation is enabled. If the button is continuously illuminated in red the front panel operations are not possible. Press and keep the **Control Lock** button pressed for three seconds to toggle between the control lock states.

4.4.7. Save or Load a Preset



The matrix can store user-programmable presets. Each preset stores a configuration regarding all input connections for all outputs. All presets are stored in a non-volatile memory; the router keeps the presets even in the case of a power down. Please note, that preset operations can be followed on the LCD during front panel preset operations.

ATTENTION! Eight of the memory slots are available by the Source buttons; see [Presets Tab](#) for the details.

Saving a Preset in Take Mode

Step 1. Press and release **Save Preset** button.



Step 2. Press and release the desired **source (memory address) button** (source 1 to 8).



Step 3. Press and release the **Take** button. Now the current configuration is stored in the selected memory.



ATTENTION! Preset save action always stores the current configuration for all outputs.

Loading a Preset in Take Mode

Step 1. Press and release the **Load preset** button.



Step 2. Press and release the desired **source (memory address) button** (source 1 to 8).



Step 3. Press and release the **Take** button. Now the selected preset is loaded.



Saving a Preset in Autotake Mode

Step 1. Press and release the **Save Preset** button.



Step 2. Press and release the desired **source (memory address) button** (source 1 to 8). Now the current configuration is stored in the selected memory.



ATTENTION! Preset save action always stores the current configuration for all outputs.

Loading a Preset in Autotake Mode

Step 1. Press and release Load Preset button.



Step 2. Press and release the desired source (memory address) button (source 1 to 8). Now the selected preset is loaded.



4.5. Front Panel Operations – Quick Summary

4.5.1. Take Mode

View Input Connections

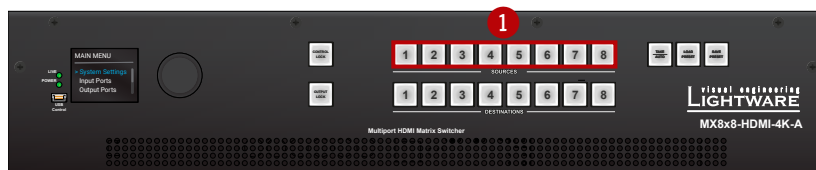

View Output Connections



Change Connections

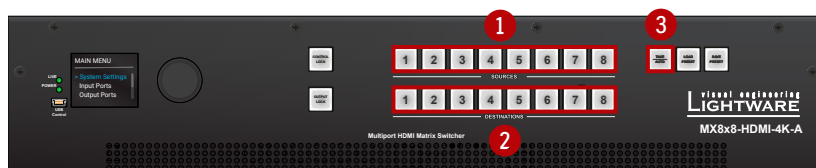

Save a Preset

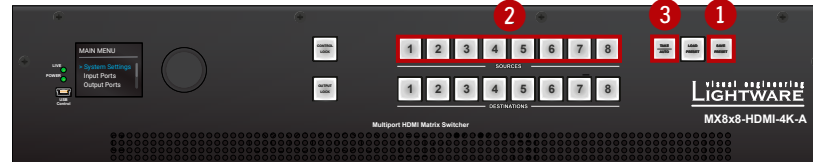

Load a Preset

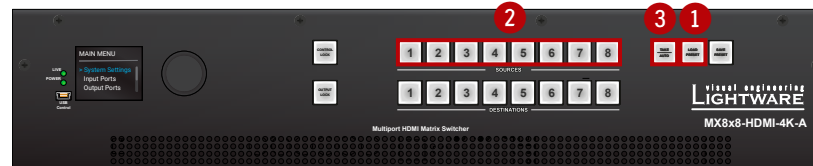

View Locked Outputs



Lock/Unlock an Output

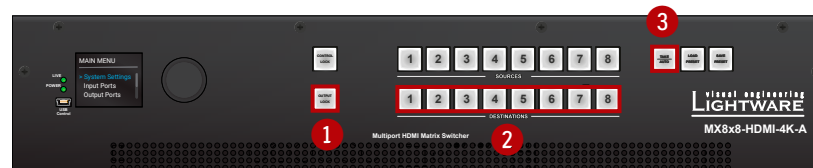

4.5.2. Autotake Mode

View Current State



Create a Connection

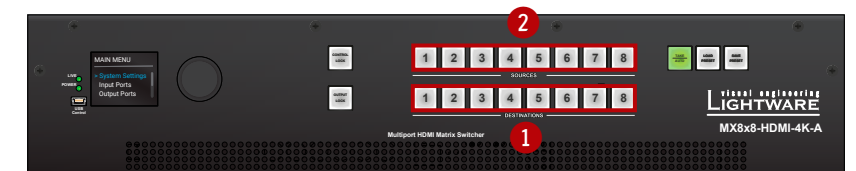

Save a Preset



Load a Preset

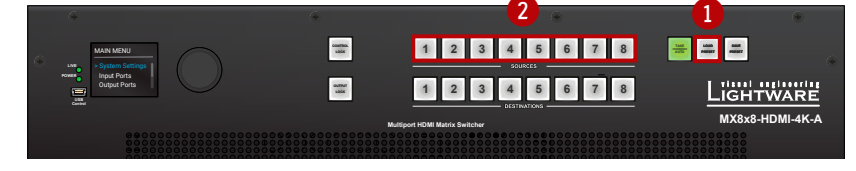

View Locked State of an Output



Lock/Unlock an Output

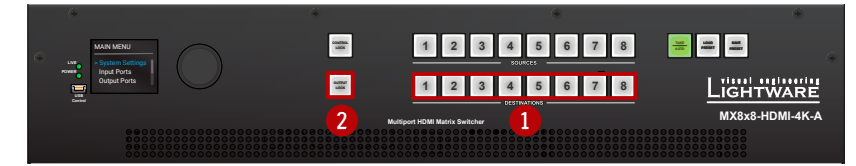

5

Software Control – Lightware Device Controller

The matrix can be controlled by a computer through the LAN or USB ports using Lightware Device Controller (LDC). The software can be installed on a Windows PC or macOS. The application can be downloaded from www.lightware.com. The Windows and the Mac versions have the same look and functionality.

- ▶ INSTALL AND UPGRADE
- ▶ RUNNING THE LDC
- ▶ DEVICE DISCOVERY WINDOW
- ▶ CROSSPOINT MENU
- ▶ VIDEO TAB
- ▶ DIAGNOSTIC TOOLS
- ▶ AUDIO TAB
- ▶ PRESETS TAB
- ▶ EDID MENU
- ▶ CONTROL MENU
- ▶ EVENT MANAGER
- ▶ SETTINGS MENU
- ▶ CONFIGURATION CLONING (BACKUP TAB)
- ▶ ADVANCED VIEW

5.1. Install and Upgrade

Installation for Windows OS

- Step 1.** Run the installer. If the User Account Control drops a pop-up message click Yes.
- Step 2.** During the installation you will be prompted to select the type of the installation: **normal** and the **snapshot** install:

Normal install	Snapshot install
Available for Windows and macOS	Available for Windows
The installer can update only this instance	Cannot be updated
Only one updateable instance can exist for all users	Different versions can be installed for all users

Comparison of the Installation Types

ATTENTION! Using the Normal install as the default value is highly recommended.

Installation for macOS

INFO: After the installation, the Windows and the Mac application has the same look and functionality. This type of the installer is equal with the Normal install in the case of Windows and results an updateable version with the same attributes.

Mount the DMG file with double clicking on it and drag the LDC icon over the Applications icon to copy the program into the Applications folder. If you want to copy the LDC into another location just drag the icon over the desired folder.

The Upgrading of the LDC

- Step 1.** Run the application.

The **Device Discovery** window appears automatically and the program checks the available updates on Lightware's website and opens the update window if the LDC found updates.

The current and the update version number can be seen at the top of the window and they are shown in this window even with the snapshot install.

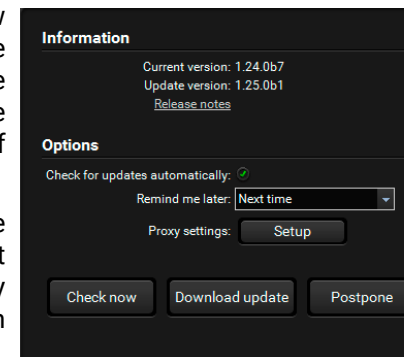

The **Update** window can be opened manually by clicking the **question mark** and the **Update** button.

- Step 2.** Set the desired update setting in the **Options** section.

- When the **Check for updates automatically** option is marked, the LDC tries to find a new version after startup.
- If you want to postpone the update, set the reminder by the **drop down list**.
- If necessary, the proxy settings are available by clicking the **Setup** button.

- Step 3.** Click the **Download update** button to start the downloading.

- Step 4.** When the download process finished, the **Download Update** button changes to **Launch update**. Click it on to install the new version.

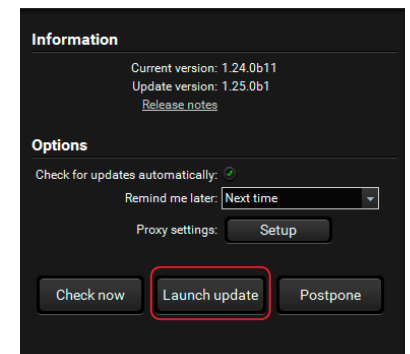

5.2. Running the LDC

The common way to start the software is double-click on the LDC icon. But the LDC can be run by command line parameters as follows:

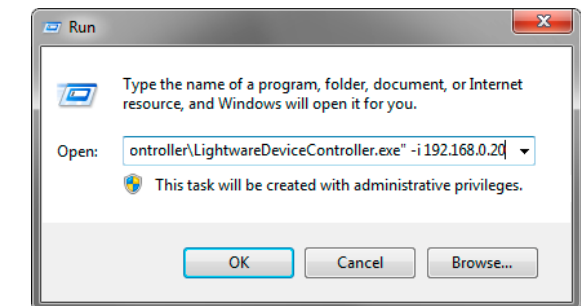

Connecting to a Device with Static IP Address

Format: LightwareDeviceController -i <IP_address>:<port>

Example: LightwareDeviceController -i 192.168.0.20:10001

The LDC is connected to a device with the indicated static IP address directly; the Device Discovery window is not displayed. When the port number is not set, the default port is used: 10001 (LW2 protocol). For LW3 devices use the 6107 port number.

5.3. Device Discovery Window

There are three tabs for the different type of interfaces, select the Ethernet, Serial devices or USB tab.

N.	IP	Port	Product name	Device label	Local alias	Serial number
1	192.168.0.32	6107	UMX-TPS-TX140	UMX-TPS-TX140	Add local alias	00002212
2	192.168.1.104	6107	HDMI20-OPTC-TX220-PRO	HDMI20-OPTC-TX220-PRO	Add local alias	00005088
3	192.168.0.100	6107	MMX8x8-HDMI-4K-A	MMX8x8-HDMI-4K-A	8x8	00005482
4	192.168.3.62	6107	MMX8x4-HT400MC	MMX8x4-HT400MC	Add local alias	00005488
5	192.168.3.58	6107	MMX8x4-HT420M	MMX8x4-HT420M	Add local alias	00005483

IP	Port	Product name	Device label	Serial number
192.168.3.61	6107	HDMI-TPS-TX210	HDMI-TPS-TX210	32145687
192.168.3.62	6107	MMX8x4-HT400MC	MMX8x4-HT400MC	00005488
192.168.0.99	6107	MMX8x4-HT400MC	MMX8x4-HT400MC	00005480
192.168.3.58	6107	MMX8x4-HT420M	MMX8x4-HT420M	00005483
192.168.2.128	6107	MMX8x8-HDMI-4K-A	MMX8x8-HDMI-4K-A	00005482
192.168.2.211	6107	MMX8x8-HDMI-4K-A	MMX8x8-HDMI-4K-A	00005479
192.168.3.5	6107	MX2-8X8-HDMI20-AUDIO	MX2-8X8-HDMI20-AUDIO	7B108994
192.168.2.204	6107	MX2-8X8-HDMI20-AUDIO	TST-ORIG	87654321
192.168.2.156	6107	UMX-TPS-TX140	UMX-TPS-TX140	00002179

Device Discovery Window

Establishing the Connection

Select the unit from the discovered Ethernet devices; double click on the device or select it and click on the green **Connect** button.

The Ethernet tab consists of two lists:

- **Favorite Devices:** You can add any Lightware device that is connected via Ethernet and no need to browse all the available devices. Devices can be added by pressing the **Add** button or marking the desired device by the ★ symbol in the **All Devices** list.
- **All Devices:** The Lightware devices are listed which are available in the connected network.

Further Tools

The **Tools** menu contains the following options:

- **Log Viewer:** The tool can be used for reviewing log files which have been saved previously.
- **Create EDID:** This tool opens the Easy EDID Creator wizard which can be used for creating unique EDIDs in a few simple steps. Functionality is the same as the Easy EDID Creator, for the detailed information see [Creating an EDID](#) section.
- **Demo Mode:** This is a virtual MX-FR17 matrix router with full functionality built into the LDC. Functions and options are the same as a real MX-FR17 device.

The **Terminal** window is also available by pressing its button on the bottom.

IP Address Configuration

The IP settings of a device can be changed without establishing the connection to the LDC. If the feature is supported by the device an icon is displayed next to the IP address:

Press the icon to open the IP configuration window and set the necessary parameters then press the **Apply** button (or **Cancel** to discard and exit).

Identifying the Device

Clicking on the icon results a **Device identified!** message on the LCD screen. The feature helps to identify the device itself in the rack shelf.

This will change the IP address settings of the selected device remotely.

DHCP Fix IP

Serial number: 00005480

IP Address: 192.168.0.99

Network mask: _____

Default gateway: _____

Apply Cancel

5.4. Crosspoint Menu

When LDC finds the hardware, it determines the product type, and the LDC starts with the default page, showing the Crosspoint menu.

MMX8x4-HT400MC



MMX8x4-HT420M



MMX8x8-HDMI-4K-A

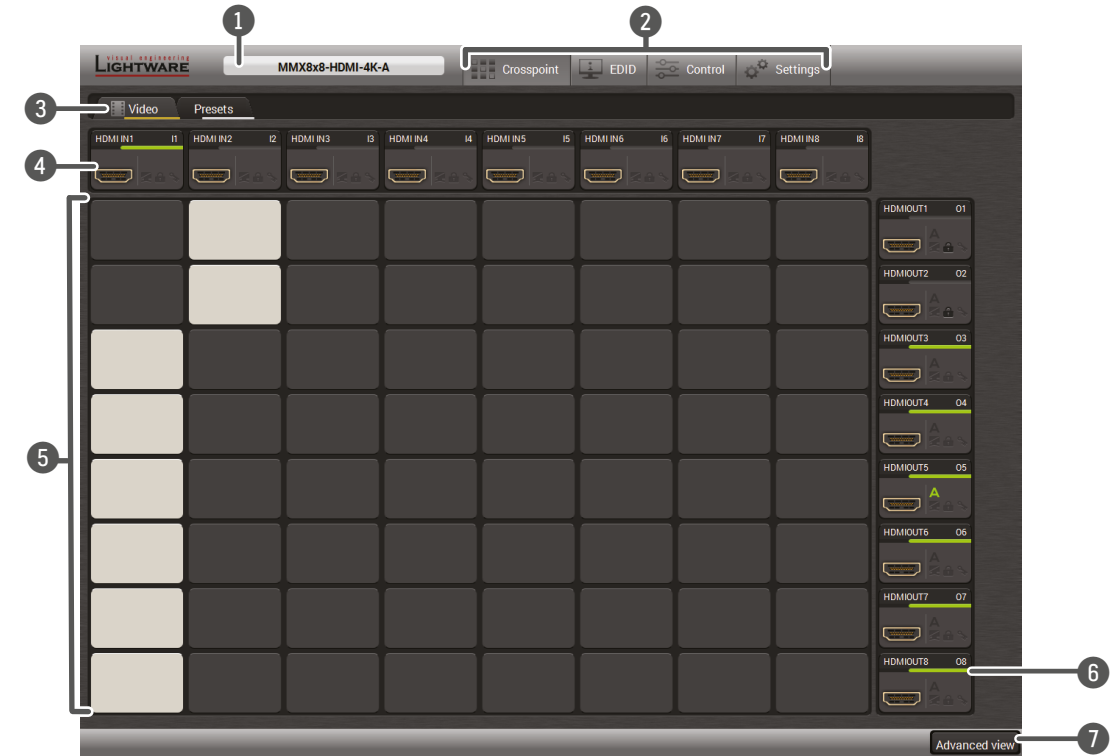

- 1 **Device Label** The **Device Discovery** window can be opened by clicking on this ribbon. The Device Label is displayed which is not the same as the Product Name. The Product name is displayed in a hint box when the mouse cursor is above the box. See more information in [Status](#) section.
- 2 **Main Menu** The available menu items are displayed. The active one is highlighted with a dark grey background color.
- 3 **Tab Selector Ribbon** Select the desired [Video Tab](#), [Audio Tab](#), or [Presets Tab](#).
- 4 **Input Ports** Each number represents an input port. Click on the port to display the [TPS Input Port Properties](#) and [HDMI Input Port Properties](#) window.
- 5 **Connections** **Grey** square means the port is available but there is no connection. **White** square means there is a connection between the input and the output port.
- 6 **Output Ports** Each number represents an output port. Click on the port to display the [HDMI and TPS Output Port Properties](#) window.
- 7 **Advanced View** Displaying the [Advanced View](#) page, showing the Terminal window and the LW3 protocol tree.

5.4.1. Crosspoint Operations

Switching

To make a connection click on the desired square. If there is no connection between the desired input and output (the square is dark grey), the mouse pointer becomes a hand (link pointer) before the clicking. If the output port is not locked, the connection is made, the square becomes white and the cursor changes back to a pointer.

For example, Input 8 is not connected to Output 1 as shown on the first picture. If the connection is established the square becomes white.



Port Tiles

The colors of the port tiles and the displayed icons represent different states and information:

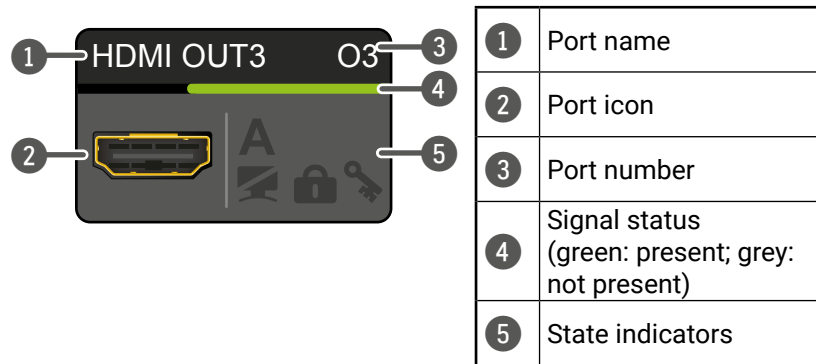

State Indicators

Icon	Icon is grey	Icon is black
	The port is unmuted	The port is muted
	The port is unlocked	The port is locked
	Signal is not encrypted with HDCP	Signal is encrypted with HDCP
Icon	Icon is grey	Icon is green
	Autoselect setting is disabled	Autoselect setting is enabled

5.5. Video Tab

5.5.1. TPS Input Port Properties

INFO: MMX8x8-HDMI-4K-A model has no TPS port.



TPS Input Port Properties Window in MMX8x4-HT420M model

Available Settings

- **Port name**
- **Mute/unmute** the port;
- **Lock/unlock** the port;
- **HDCP setting** (enable / disable);
- **TPS mode** (Auto / HDBaseT / LPPF1 in MMX8x4-HT400MC model and Auto / HDBaseT / Longreach / LPPF1 / LPPF2 in MMX8x4-HT420M model). See more details about this setting in [TPS Working Modes](#) section.
- **PoE setting*** (enable / disable): The matrix is able to supply (send remote power) devices through the TPS input and output ports which are compatible with the PoE standard.

*Only in MMX8x4-HT420M model.

Status and Signal Info

It gives a feedback about the current parameters the of the video signal:

- +5V Present / Signal present / Signal type / HDCP / TPS mode / Connected device
- Resolution / Scan / Color depth / Color space

Frame Detector

See more details about the Frame Detector in the [Frame Detector](#) section.

Emulated EDID

Displays the basic information about the emulated EDID.
EDID memory / Manufacturer / Monitor name / Preferred resolution

Other

Reloading [Factory Default Settings](#) for the selected port.

5.5.2. HDMI Input Port Properties

Click on a port to display its properties; Signal status information and the most important parameters are displayed.

Input 5 - HDMIIN5

Settings

Port name: HDMIIN5 [Set]

Mute / Lock: [Mute] [Lock]

HDCP enable:

Audio mode: Embed from aux audio

Analog audio input settings

Mute:

Volume: 100 [Slider]

Volume (dB): 0.00

Balance: 0 [Slider]

Gain: 0.00 [Slider]

Status

+5V present: present

Signal present: present

Signal type: HDMI

HDCP: none

Signal info

Resolution: 1920x1080p60

Scan: progressive

Color depth: 8 bits per pixel

Color space: RGB

Frame detector

Frame detector: [Frame detector]

Emulated EDID

EDID memory: F47

Manufacturer:

HDMI Input Port Properties Window in MMX8x4-HT420M model

Available Settings

- Port name
- Mute/unmute the port;
- Lock/unlock the port;
- HDCP setting (enable / disable);
- Audio mode (HDMI audio passthrough / Embed from aux audio / Deembedded to aux audio)

Analog Audio Input Settings

The displayed configurable settings depends on the chosen audio mode.

INFO: Audio mode is available at **I5, I6** ports of **MMX8x4-HT420M** and **I2, I4, I6, I8, O2, O4** ports of **MMX8x8-HDMI-4K-A** model.

Depending on the chosen audio mode the following parameters can be set:

HDMI audio passthrough

The embedded audio of the HDMI signal will be transmitted without any modification.

Embed from aux audio

Audio embedder is able to add (or replace) an audio stream to an HDMI video.

Analog audio input settings

Mute:

Volume: 100 [Slider]

Volume (dB): 0.00

Balance: L 44 [Slider]

Gain: 0.00 [Slider]

- Mute/unmute
- Volume: from 100 to 0%, in step 1% (0 dB to -48.18dB, default is 0 dB)
- Balance from L 100 to R 100, in step 1 (default is 0 = center)
- Gain from 0.00 to 24.00, in step 1.00 (default is 0.00)

Deembedded to aux audio

Audio de-embedder is able to separate the HDMI video and audio.

Analog audio output settings

Mute:

Volume: 100 [Slider]

Volume (dB): 0.00

Balance: 0 [Slider]

- Mute/unmute
- Volume: from 100 to 0%, in step 1% (0 dB to -95.62dB, default is 0 dB)
- Balance from -100 to 100, in step 1 (default is 0 = center)

Status and Signal Info

It gives a feedback about the current parameters the of the video signal:

- +5V Present / Signal present / Signal type / HDCP
- Resolution / Scan / Color depth / Color space

Frame Detector

See more details about the Frame Detector in the [Frame Detector](#) section.

Emulated EDID

Displays the basic information about the emulated EDID.

EDID memory / Manufacturer / Monitor name / Preferred resolution

Other

Reloading [Factory Default Settings](#) for the selected port.

CEC

The MMX8x4-HT series matrix switchers are able to send and receive Consumer Electronic Control (CEC) commands. This feature is for remote control of the source or sink device. CEC is a bi-directional communication via HDMI cable, in this case between the output port of the matrix switcher and the sink.

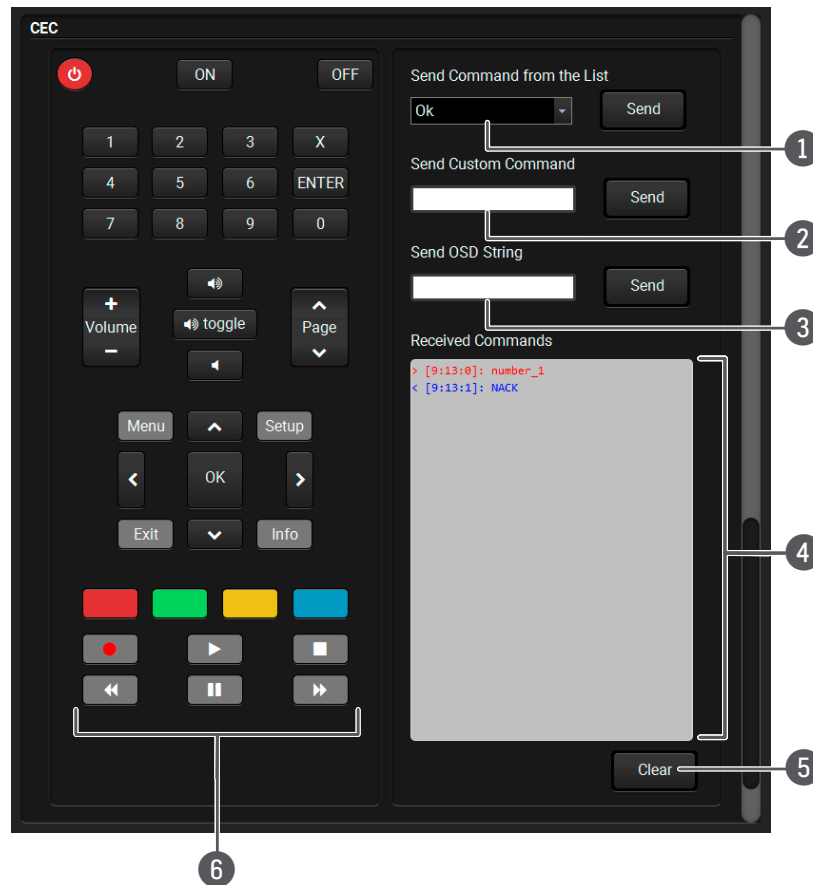

Layout of CEC panel in Lightware Device Controller

- 1 Drop-down command list** This list contains the basic CEC commands, most of them are displayed on the graphical interface, too (on the left side). Click on the **Send** button to execute sending the command.
- 2 Custom command textbox** The text field is for sending hexadecimal commands to the source. The maximum length of the message could be 30 characters (15 bytes). Click on the **Send** button to execute sending the command.
- 3 OSD string textbox** A max. 14 character-long text can be shown on the sink device. The send OSD (On-screen display) command textbox is the input field of the string. Alphanumeric characters, glyphs and space are accepted. Click on the **Send** button to execute the command.
- 4 Received Command box** Displays all the sent (in red) CEC commands and the received answers (in blue) with a timestamp.
Legend of the received message:
< [10:33:17] ACK
 Answer for the acknowledged command.
< [10:35:01] NACK
 Answer for the not acknowledged command.
< [10:33:17] IN PROGRESS
 The command is in progress at the moment.
< [10:33:17] FAILED
 Answer for other failure.
< [10:35:40] feature_abort_<*>
 This is the most common answer from the third-party devices when the command is delivered, but the execution is refused. The cause of the refuse stands after 'feature_abort' expression.
- 5 Clear button** Click on the **Clear** button to erase the content of the terminal window.
- 6 CEC command button panel** This panel provides the quick and easy management of CEC commands. These buttons are pre-programmed with basic functions and sends commands towards the sink. The communication is displayed in the Received Command box. For the list of the commands see [Send CEC command in text format](#) section. Both the layout and functionality are similar to the design of a remote control.

It can occur that the third-party device can receive, but not execute the command because it is not supported by the product. Check the accepted commands in the documentation of the device.

INFO: The first 2x2 bit of the CEC commands contains identification data of the source and destination address. In this case that is always 40.

ATTENTION! Make sure that the controlled unit is CEC-capable and this function is enabled.

5.5.3. HDMI and TPS Output Port Properties

INFO: MMX8x8-HDMI-4K-A model has no TPS output port.

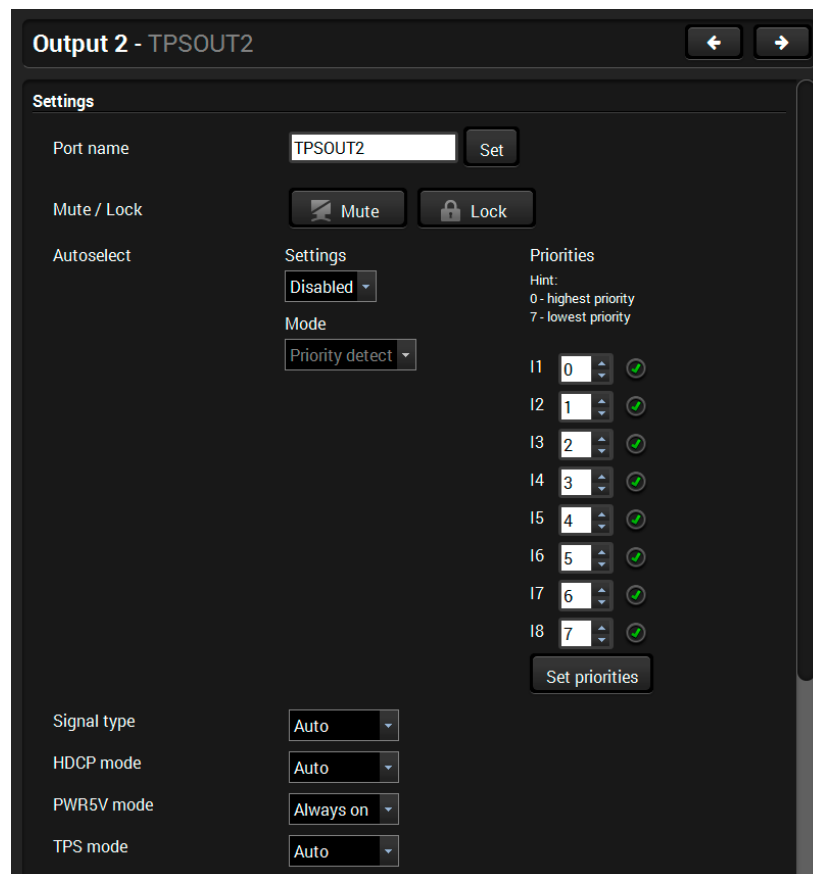

TPS Output Port Properties Window

Available Settings

- **Port name**
- **Mute/unmute** the port;
- **Lock/unlock** the port;
- **Autoselect settings** (Enabled / Disabled, Mode and Priorities) See more details about this feature in [The Autoselect Feature](#) section. Pay attention for the following settings for the proper operation of Autoselect function:
 - Set the Autoselect settings to **Enabled**;
 - Be sure that no input is set to the same priority number;
 - Be sure that all priority values are filled in (no empty space);
 - Be sure that all inputs are enabled with the green checkbox on the right side;
 - Always click on the **Set priorities** button after the changes to launch the new settings.
- **Signal type** (Auto / DVI / HDMI);
- **HDCP mode** (Auto / Always): The transmitter forces the source sent the signal without encryption if the content allows when **Auto mode** is selected.
- **PWR5V mode** (Auto / Always on / Always off): The setting lets the source and the sink devices be connected – independently from the transmitted signal;
- **Audio mode** (only in **O2** and **O4** ports of MMX8x8-HDMI-4K-A model);
- **TPS mode*** (Auto / HDBaseT / Longreach / LPPF1 / LPPF2). See more details about this setting in [TPS Working Modes](#) section.
- **PoE setting*** (enable / disable): The matrix is able to supply (send remote power) devices through the TPS input and output ports which are compatible with the PoE standard.
- **Cable Diagnostics** (in TPS port)*; For more details see [Cable Diagnostics](#) section.

*TPS related settings can be found only in TPS output properties window.

Analog audio settings

The displayed configurable settings depends on the chosen audio mode. For more details see [Analog Audio Input Settings](#) section.

No sync screen

Configuration settings of the test pattern. See more details in the [Test Pattern Generator - No Sync Screen](#) section.

Status and Signal Info

It gives a feedback about the current parameters the of the video signal:

- Monitor Present / Signal present / Signal type / HDCP / Hotplug detect
- Resolution / Scan / Color depth / Color space

Display

This section gives a feedback about the basic information of the connected sink device.

- Display name / Preferred resolution / HDMI capable / HDCP capable /HDCP repeater / Deep Color Support / Deep Color YUV support

Frame Detector

See more details about the Frame Detector in the [Frame Detector](#) section.

CEC

See more details about the CEC feature in [CEC](#) section.

Other

Reloading [Factory Default Settings](#) for the selected port.

5.6. Diagnostic Tools

5.6.1. Cable Diagnostics

The cable diagnostics is a useful tool to determine any cable related issues in case of TPS connection. The estimated cable length and the quality of the link are measured periodically and the diagnostic window shows the values in real-time. If the green bars hit the first line in the middle they turn into red. It means the number of the errors – during the extension – is higher than recommended. The link might be alive but recovering of the received data is not guaranteed.

INFO: Each bar represents a differential line in the CATx cable. The inappropriate termination of the cable usually causes high error rates. Check the cable terminations or change the cable.

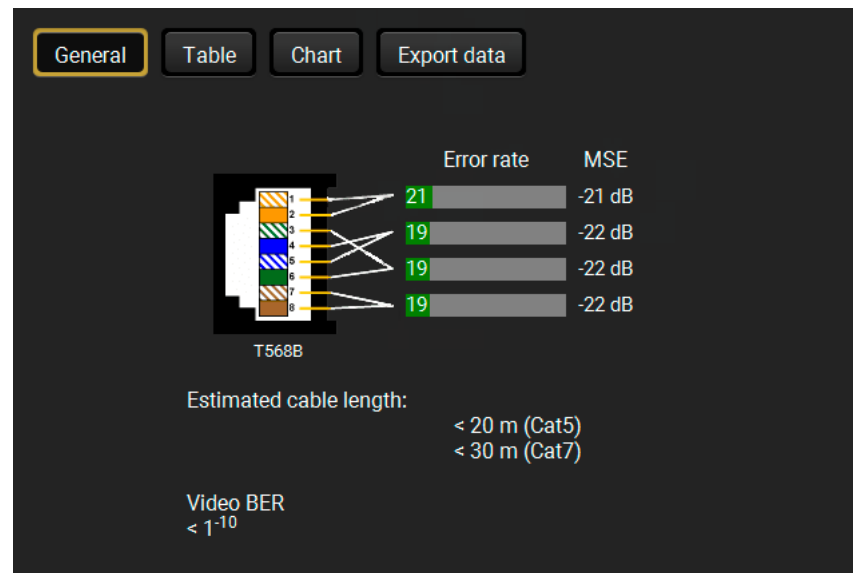

Cable Diagnostic Window

Reference Values

Value	Explanation
10 ⁻¹⁰ -10 ⁻⁹	Excellent image quality
10 ⁻⁸	Minor error, not recognizable by eyes
10 ⁻⁷	Sometimes recognizable flash on a special test pattern
10 ⁻⁶	Small noise can be seen
10 ⁻⁵	Easy to recognize image error
10 ⁻⁴	Bad image quality

Above displayed "Video BER < 10⁻¹⁰" value means that on average there is 1 bad pixel after 10¹⁰ pixels, which means the number of the bit errors is about 1 pixel in every 80 seconds.

INFO: You can find more details about maximum twisted pair cable distances in the [Maximum Extension Distances](#) section.

Table and Chart Views

Cable diagnostics can be displayed in advanced modes as well. Two ways are available: **table view** and **chart view**. Data can be exported to a file on clicking on the **Export data** button.

Date	MSE #1	MSE #2	MSE #3	MSE #4	Error rate #1	Error rate #2	Error rate #3	Error rate #4	Cable length
2018-07-05 11:11:20	-22	-22	-21	-22	19	20	19	18	< 20
2018-07-05 11:11:21	-21	-22	-21	-22	18	19	20	17	< 20
2018-07-05 11:11:22	-21	-22	-21	-22	18	19	20	17	< 20
2018-07-05 11:11:23	-21	-22	-21	-22	18	19	20	17	< 20

Table view of cable diagnostics

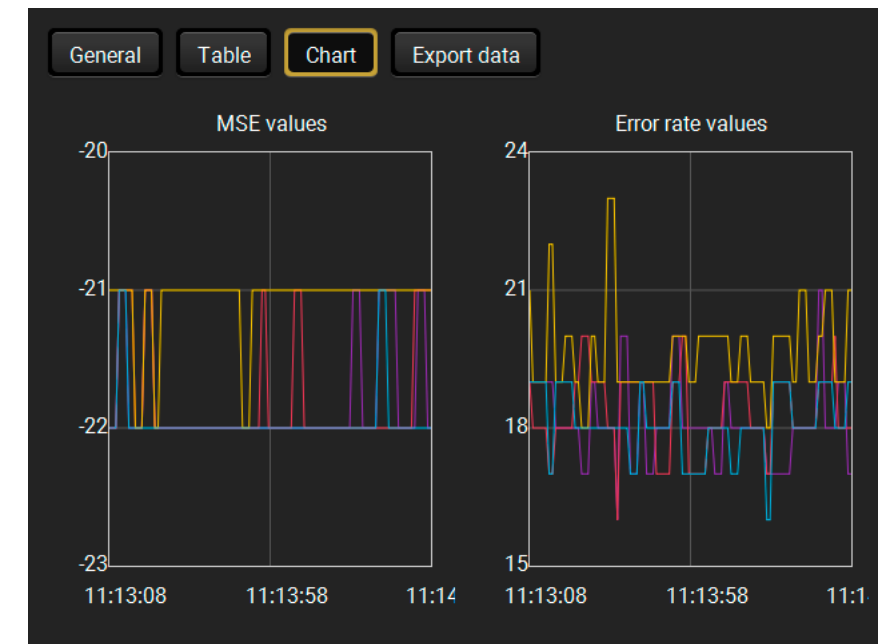
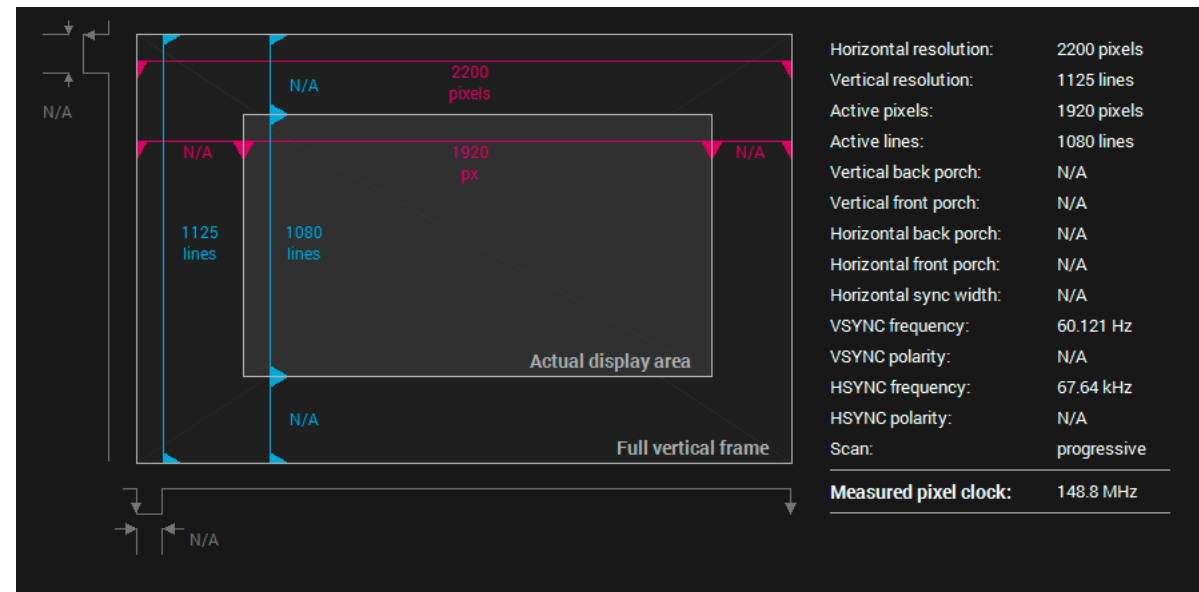

Chart view of cable diagnostics

5.6.2. Frame Detector

The ports can show detailed information about the signal like full size and active video resolution. This feature is a good troubleshooter if compatibility problems occur during system installation. To access this function, open the port properties window and click on **Frame detector** button.



Frame Detector Window

Lightware's Frame Detector function works like a signal analyzer and makes possible to determine the exact video format that is present on the port, thus helps to identify many problems. E.g. actual timing parameters may differ from the expected and this may cause some displays to drop the picture.

Frame Detector measures detailed timings on the video signals just like a built-in oscilloscope, but it is much more easy to use. Actual display area shows the active video size (light grey). Dark grey area of the full frame is the blanking interval which can contain the info frames and embedded audio data for HDMI signals. Shown values are measured actually on the signal and not retrieved only from the HDMI info frames.

5.6.3. Test Pattern Generator - No Sync Screen

The output ports can send a special image towards the sink devices for testing purposes.

The setting is available on output ports with the following parameters:

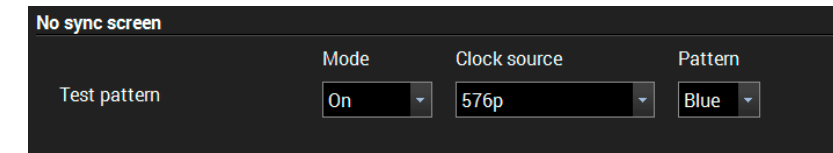

Mode

- **On:** the test pattern is always sent to the output port.
- **Off:** the test pattern generator is off.
- **No signal:** the test pattern generator is switched on if no video signal is switched to the given output port.

Clock source

- 480p / 576p / Original video signal: the clock frequency of the test pattern.

Pattern

- Red / Green / Blue / Black / White / Ramp / Chess / Bar / Cycle. Cycle setting means all the patterns are changed sequentially approx. in every 2 seconds.

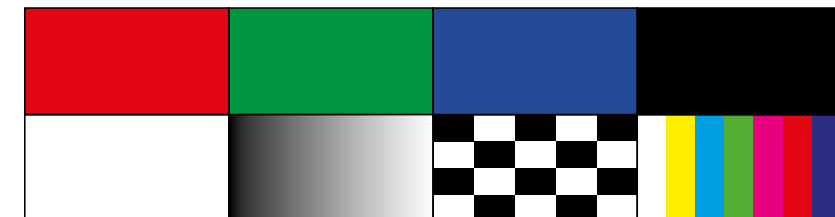

Test patterns

ATTENTION! The Mode can be set individually on each port, but the Clock source and Pattern settings are the same on O1-O3 and O2-O4 output ports.

5.7. Audio Tab

MMX8x4-HT400MC and MMX8x4-HT420M model

This tab is for overview of the input and output audio settings. See more details about the audio inputs and outputs in [Audio Interface](#) section.



Audio tab in Crosspoint menu

Basic settings can be seen on the default view:

TIPS AND TRICKS: The entire view with full functionality of each channel is available by clicking on the channel separator button. Clicking on this button once again closes the advanced layout.

5.7.1. Panorama or Balance Settings

Panorama property is available in microphone input settings. It defines, that the balanced microphone input is transmitted to the left or right channel of the balanced analog output.

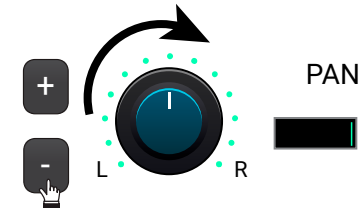

Balance parameter is available in advanced analog input, embedded audio and advanced analog output channel.

Panorama and Balance can be set separately in each channel.

They can be configured three ways:

- Click on the knob and keep pressed the left button. Move the cursor up or down to set the lower or higher value.
- Press + or - buttons to increase or decrease the value.
- Type the value into the text field. (L1-6 for the left side, R1-6 for the right side, 0 means the center.)

TIPS AND TRICKS: Double click on the knob restore the default value (0= center).

5.7.2. Gain Settings

See the advanced layout to reach all adjustable properties.

Gain setting is for increase (or decrease) the input signal level, expressed in dB.



Gain values in microphone input channel:

Min. level: -12dB, max. level: +55dB, default level: 0dB. Steps: 1dB.

Gain values in advanced analog audio channel:

Min. level: -12dB, max. level: +21dB, default level: 0dB. Steps: 3dB.

These sections can be configured three ways:

- Click on the knob and keep pressed the left button. Move the cursor up or down to set the lower or higher value.
- Press + or - buttons to increase or decrease the value.
- Type the value into the text field.

5.7.3. Equalization (EQ) Settings

See the advanced layout to reach all adjustable properties.

The equalizer section is for set the proper rate of the different frequencies.



EQ frequencies in microphone input channel:

HIGH: 12kHz; HIGH-MID: 1.6 kHz, LOW-MID: 400Hz, LOW: 120Hz.

EQ frequencies in the other advanced audio channels:

HIGH: 8kHz; HIGH-MID: 1.6 kHz, LOW-MID: 400 Hz, LOW: 100Hz.

EQ parameters can be set separately in each channel, the values are between -18dB +18dB. Default level: 0dB (zero modification in the original signal). Steps: 3dB.

These sections can be configured three ways:

- Click on the knob and keep pressed the left button. Move the cursor up or down to set the lower or higher value.
- Press + or - buttons to increase or decrease the value. Steps: 3dB.
- Type the value into the text field (between -18 and +18).

TIPS AND TRICKS: Double click on the knob restore the default value (0= center).

Equalization (EQ) setting example

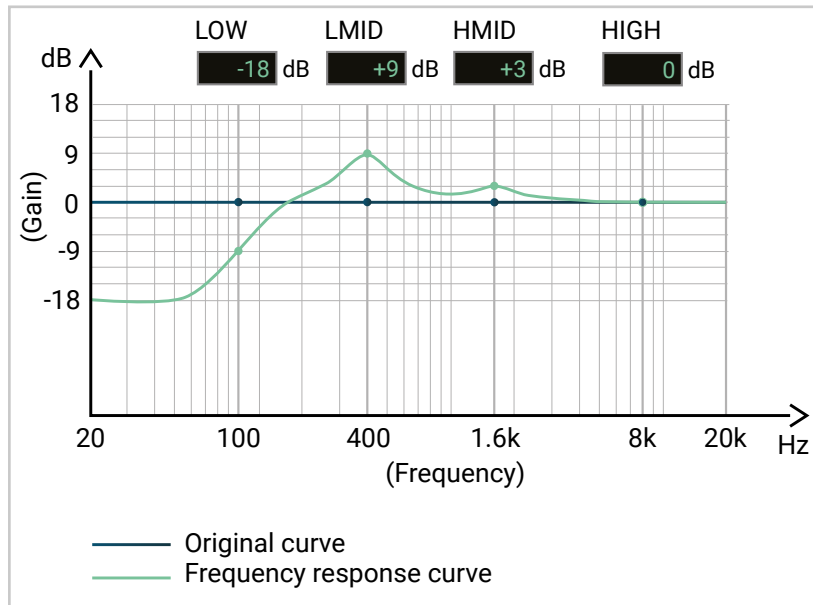

This example shows how EQ settings affect to the audio signal:

- 18 dB was set for the LOW frequencies;
- +9 dB was set for the LOW-MID frequencies;
- +3 dB was set for the HIGH-MID frequencies;
- 0 dB was set for the HIGH frequencies;

TIPS AND TRICKS: Adjust the Low, Low-mid, High-mid, High values to 0 is recommended as the first step of the EQ settings. Pursue apply minimal modification of the original signal.

5.7.4. Signal Indicator Chart

This section gives a feedback about the actual level of the audio signal:

- In microphone input and advanced analog audio input channel, the displayed status depends on the actual level of the input signal and the gain setting.
- In the embedded audio channel, it depends on the actual level of the input signal.
- In case of the advanced analog output, it depends on the actual level of the three audio signals (mic in, advanced audio input, embedded audio), gain settings, and the input volume settings.

Left circle refers to the left channel, right circle to the right channel.

Signal indicator lights up when the signal level is above:

	Explanation	Displays a recommended setting
● PK!	PK! (Peak)	Take care that peak led (PK!) never lights up!
● NOM.	NOM. (Nominal)	Occasionally lights up.
● SIG.	SIG. (Signal)	Continuously lights (If it does not light, signal level is too low.)

ATTENTION! Take care that peak led (PK!) never lights up!

5.7.5. Digital Audio Selector Menu

The drop-down menu can be seen in the layout of embedded input channel. This is for selecting the digital audio channel. This setting affects to the crosspoint, it connects the chosen input to the analog audio output (O5).

Lock icon shows that the port can not be chosen (it was locked).

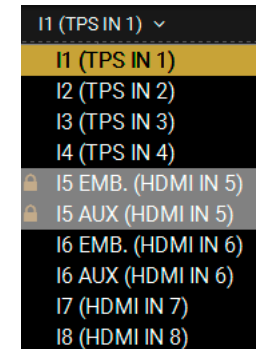

5.7.6. Scenes

8 memory slots are available to save all audio properties of the audio mixer (Settings of Mic In, Audio In, Embedded or Aux In and Audio Out Channel).

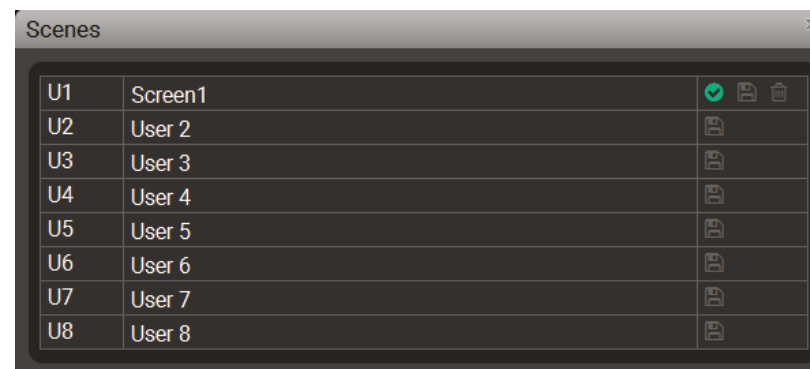

Save a scene

- Step 1. Do the required configuration in the advanced audio window.
- Step 2. Click on a **Scenes** button to open the **Scenes** window.
- Step 3. Add a custom name of your scene. Click on the name entry field and type the custom name.
- Step 4. Select a desired a scene and click a icon to save the actual configuration.

Load a scene

- Step 1. Click on a **Scenes** button to open the **Scenes** window.
- Step 2. Choose the proper scene and click the icon beside to load it.

Delete a scene

- Step 1. Click on a **Scenes** button to open the **Scenes** window.
- Step 2. Choose the proper scene and click the icon beside to delete it.

5.7.7. Microphone Input Channel



5.7.8. Legend of Microphone Input Channel

- 1 **Channel name** Displays the channel name. All the settings below belongs to the channel.
- 2 **Phantom power button** Keep pressed the button for more then 2 sec to switch on and off the 48V DC. It gives remote powering via the microphone cable to the condenser microphones.

ATTENTION! Application of the phantom power can cause a damage if dynamic or wireless microphone is connected!
- 3 **Phase invert button** It inverts the phase of the input signal.
- 4 **Feedback button** Turning on this feature hides the Feedback phenomenon. Before applying this button, check if gain or the volume could be decreased.
- 5 **Preset Button** Clicking on this button opens a **Mic Input Channel Preset** window. For more details see [Channel Presets](#) section.
- 6 **Gain section** GAIN setting is for increase (or decrease) the input microphone signal level, expressed in dB. For more information see [Gain Settings](#).
- 7 **HPF button** High-pass filter lets pass the microphone signals above 100Hz frequency. Click on the button to toggle turn it on and off.
LPF button Low-pass filter lets pass the microphone signals under 15kHz frequency. Click on the button to toggle turn it on and off.

- 8 **EQ section: HIGH, HMID, LMID, LOW** The equalizer section is for set the proper rate of the different frequencies (high: 12kHz; high-mid: 1.6 kHz, low-mid: 400Hz, low: 120Hz). For more details, see [Equalization \(EQ\) Settings](#).
- 9 **Mic preset** Five factory presets are available for microphone input channel. These are specialized for the most common microphone types. For more details see [Factory MIC presets](#) section.
- 10 **Factory defaults button** Restore the factory default settings on te microphone channel. For more details see [Factory Default Settings](#).
- 11 **Input volume fader** Sets the volume of the input microphone signal between -80dB and +10dB. It also can be controlled by scrolling or writing the value in the text field.
- 12 **Signal indicator chart** This section gives a feedback about the actual level of the input signal. See more details in [Panorama or Balance Settings](#) section.
- 13 **Mute/Unmute** Mutes/unmutes the microphone input.
- 14 **Panorama section** This setting defines, that the balanced microphone input is transmitted to the left or right channel of the balanced analog output. For more details, see [Panorama or Balance Settings](#).

ATTENTION! Not proper setting could damage the device!

See more details about connect the microphone in [Installation Guide for Connecting a Microphone](#) section.

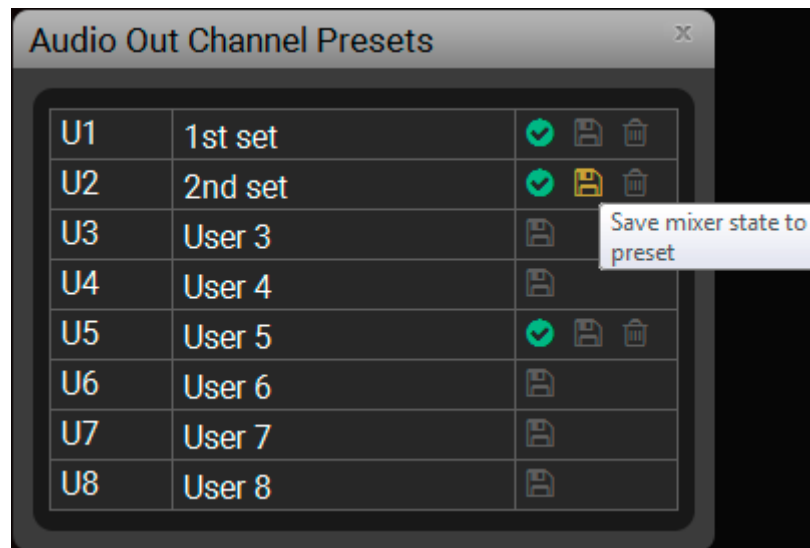

Channel Presets

Eight memory slots make possible to save the audio properties for each channel and reload them quick and easy. Each preset stores a configuration of the belonging channel. All presets are stored in a non-volatile memory; the router keeps presets even in the case of power down. The presets can be run by sending protocol commands, too. For more details about the LW3 commands see [Audio Presets](#) section.





Audio Out Channel Presets Window



Save a preset

- Step 1.** Do the required configuration of the channel.
- Step 2.** Click on a  button (beside the channel name) to open the **Channel Preset** window.
- Step 3.** Add a custom name of your preset. Click on the name entry field and type the custom name.
- Step 4.** Select a desired user preset and click on a  icon to save the actual configuration.

Load a preset

- Step 1.** Click on a  button (beside the channel name) to open the **Channel Preset** window.
- Step 2.** Choose the proper preset and click the  icon beside to load it.

Delete a preset

- Step 1.** Click on a  button (beside the channel name) to open the **Channel Preset** window.
- Step 2.** Choose the proper preset and click the  icon beside to delete it.

Factory MIC presets

Five factory presets are available for microphone input channel. These are specialized for the most common microphone types:

- Lavarier (condenser)
- Boundary (condenser)
- Gooseneck
- e945 (dynamic)
- SM58 (dynamic)

The presets contain special EQ settings, so when a factory preset is loaded, EQ settings become inactive and they can not be modified. The other parameters (e.g. volume, gain, panorama) can be changed.

Manual setting makes possible to configure EQ values manually.

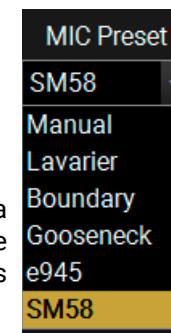

5.7.9. Advanced Analog Input Channel

This settings refers to the advanced analog audio signal.

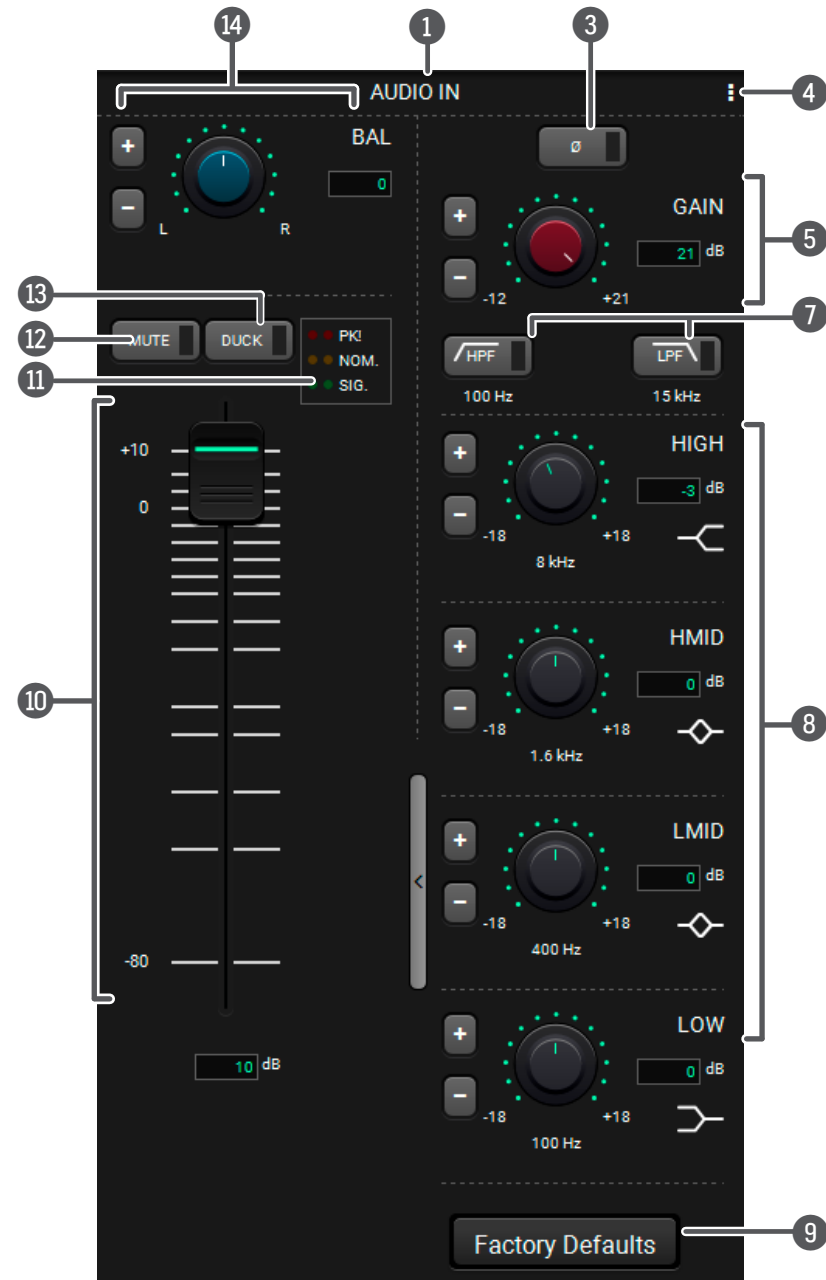

5.7.10. Embedded or Analog Input Channel

This settings refers to the chosen audio of the embedded HDMI signal (or the analog audio signal).

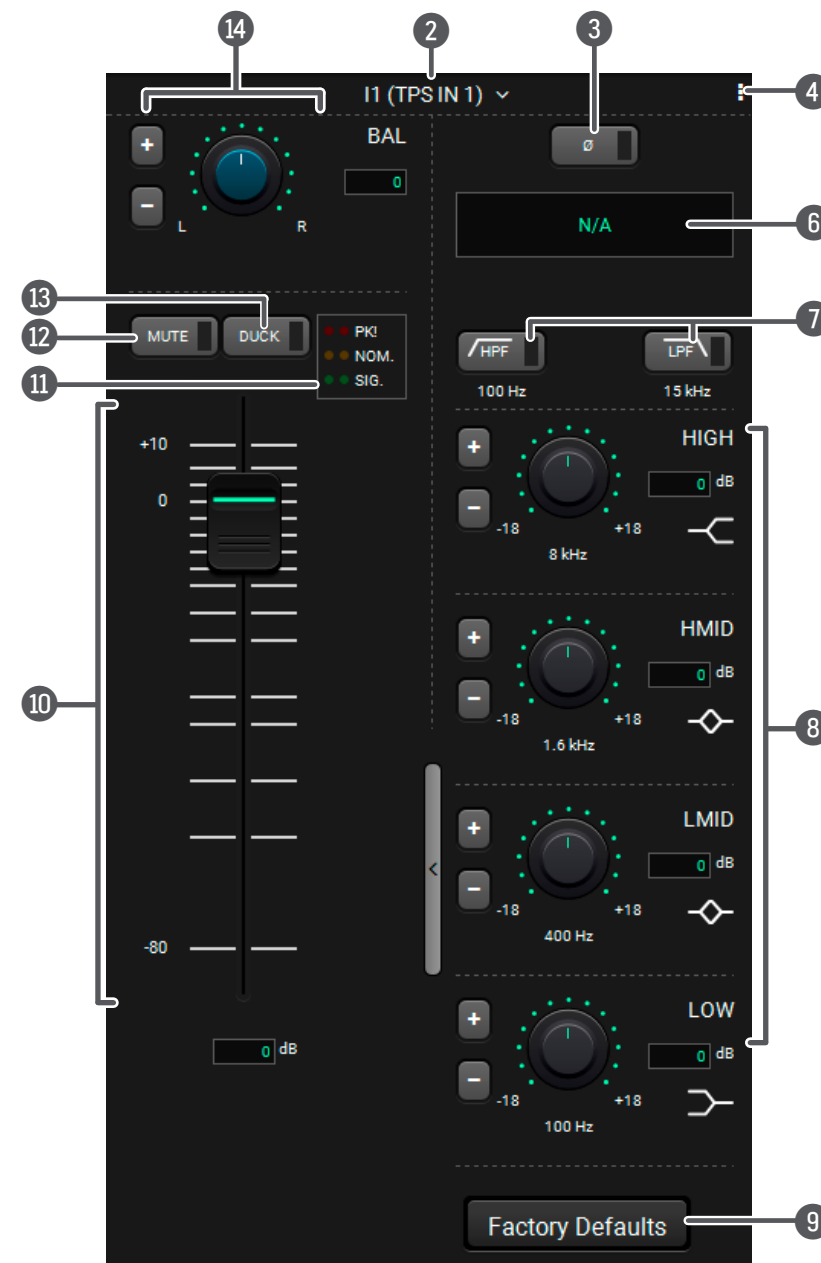

5.7.11. Legend of Embedded or Advanced Input Channel

- 1 **Channel name** Displays the channel name. All the settings below belongs to the channel.
- 2 **Digital audio selector menu** Drop-down menu for selecting the digital audio channel. For more details see [Digital Audio Selector Menu](#) section.
- 3 **Phase invert button** It inverts the phase of the input signal.
- 4 **Preset button** Clicking on this button opens a **Channel Preset** window where the channel presets can be saved, loaded or deleted. For more details see [Channel Presets](#) section.
- 5 **Gain section** GAIN setting is for increase (or decrease) the input signal level, expressed in dB. For more information see [Gain Settings](#).
- 6 **Sampling frequency display** It shows the sampling frequency of digital audio.
- 7 **HPF button/LPF button** High-pass filter lets pass the audio signals above 100Hz frequency. Click on the button to toggle turn it on and off.
Low-pass filter lets pass the audio signals under 15kHz frequency. Click on the button to toggle turn it on and off.
- 8 **EQ section: HIGH, HMID, LMID, LOW** The equalizer section is for set the proper rate of the different frequencies (high: 8kHz; high-mid: 1.6 kHz, low-mid: 400 Hz, low: 100Hz). See more details in [Equalization \(EQ\) Settings](#) section.
- 9 **Factory defaults restore button** Restore the factory default settings on the microphone channel. For more details see [Factory Default Settings](#).
- 10 **Input volume fader** Sets the volume of the input audio signal between -80dB and +10dB. It also can be controlled by scrolling or writing the value in the text field.
- 11 **Signal indicator chart** See more details in [Panorama or Balance Settings](#) section.
- 12 **Mute/Unmute** Mutes/unmutes the audio input.
- 13 **Duck button** This is a voice activation feature, allowing the volume of the voice of a person speaking into the microphone to be automatically focused, and the volume of the rest of the sounds to be lowered as soon as the presenter starts speaking.
- 14 **Balance section** Balance can be set in this section. For more details, see [Panorama or Balance Settings](#).

5.7.12. Advanced Analog Output Channel

This settings refers to the balanced analog output port.



5.7.13. Legend of Advanced Analog Output Channel

- 1 **Channel name** Displays the channel name. All the settings below belongs to the channel.
- 2 **Mono button** The same audio is transmitted to both left and right channel.
- 3 **Phase invert button** It inverts the phase of the input signal.
- 4 **Preset button** Clicking on this button opens a **Channel Preset** window where the channel presets can be saved, loaded or deleted. For more details see [Channel Presets](#) section.
- 5 **Delay button** This feature makes possible to add delay (ms) into the audio output to avoid echo effects in larger rooms. Max. value: 25ms, steps 1ms.
- 6 **EQ section: HIGH, HMID, LMID, LOW** The equalizer section is for set the proper rate of the different frequencies (high: 8kHz; high-mid: 1.6 kHz, low-mid: 400 Hz, low: 100Hz). See more details in [Equalization \(EQ\) Settings](#) section.
- 7 **Factory defaults restore button** Restore the factory default settings on the microphone channel. For more details see [Factory Default Settings](#).
- 8 **Output volume fader** Sets the volume of the output signal between -80dB and +10dB. It also can be controlled by scrolling or writing the value in the text field.
- 9 **Signal indicator chart** See more details in [Panorama](#) or [Balance Settings](#) section.
- 10 **Mute/Unmute** Mutes/unmutes the output.
- 11 **Balance section** Balance can be set in this section. For more details, see [Panorama](#) or [Balance Settings](#).

5.8. Presets Tab

The matrix has six user-programmable presets. Each preset stores a configuration regarding the crosspoint and mute state for all inputs/outputs. All presets are stored in a non-volatile memory; the router keeps presets even in the case of power down. The presets can be run from the front panel or by sending protocol commands, too.

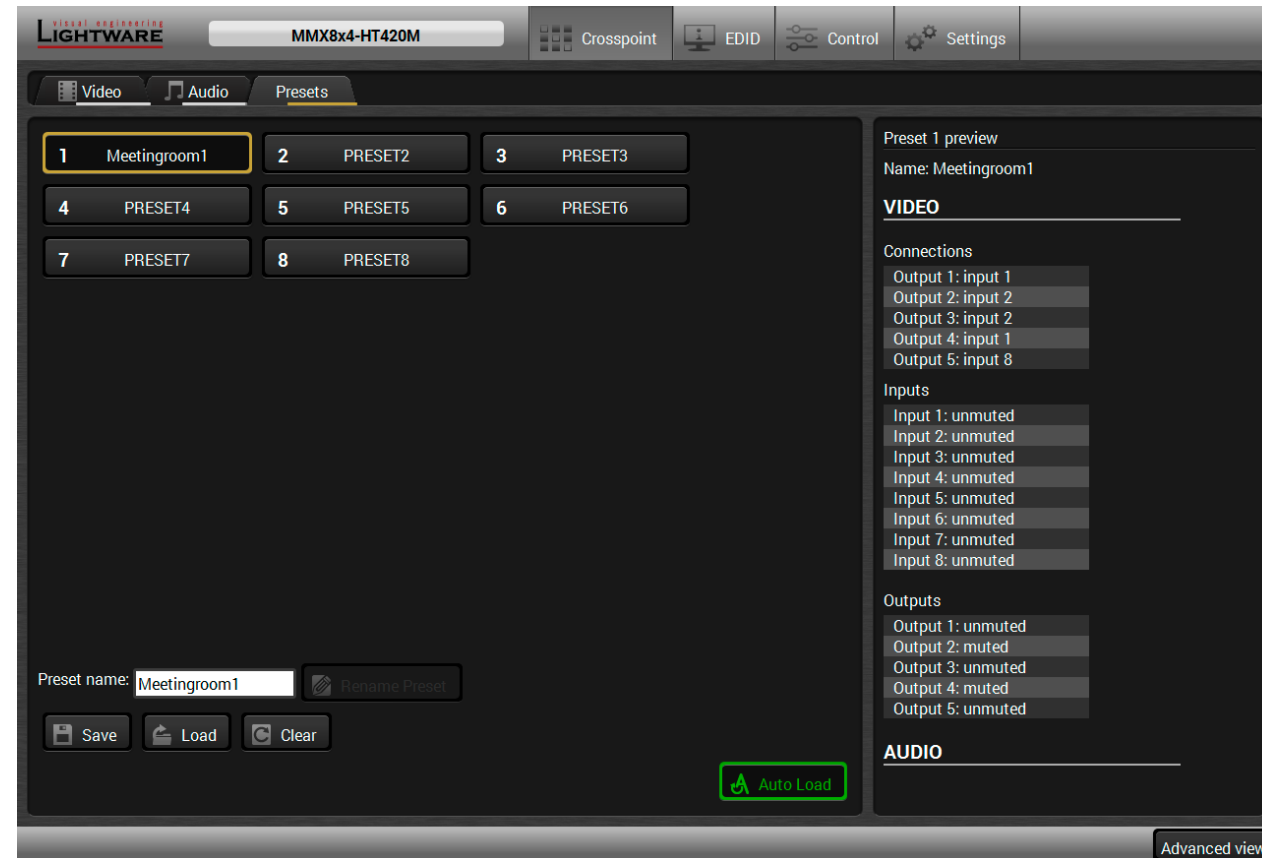

Loading a Preset

Step 1. Select the **Presets** tab from the **Crosspoint** menu.

Step 2. Select the desired preset; check the **Preview** panel and press the **Load** button. Press **Yes** in the confirmation window.

INFO: Presets which were saved by the front panel buttons previously are listed with names Preset1.. Preset8 as default. See the corresponding [Save or Load a Preset](#) section.



Saving a Preset

Step 1. Arrange the desired crosspoint connections.



Step 2. Select the Presets tab from the Crosspoint menu and choose a target preset slot from Preset 1..Preset 6. Type the desired Preset name in the indicated text field up to 16 characters. The followings are allowed when naming: letters (A-Z and a-z), hyphen (-)underscore (_), and numbers (0-9). Confirm it with **Rename Preset** button.

Step 3. Press the **Save** button and **Yes** to confirm for storing the configuration.

Renaming a Preset

Step 1. Select the desired preset you want to rename.

Step 2. Type the desired name and press the **Rename Preset** button.



Deleting a Preset

Step 1. Select the desired preset you want to delete.

Step 2. Press the **Clear** button and **Yes** to confirm



Auto Load Mode

When the **Auto Load** button is highlighted with green, the mode is active. In this case, confirmation is not required: the selected preset is loaded immediately when the button is pressed.



5.9. EDID Menu

Advanced EDID Management can be accessed by selecting the EDID menu. There are two panels: left one contains Source EDIDs, right one contains Destination places where the EDIDs can be emulated or copied.

Memory	Manu...	Resolution	Audio	Monitor Name	Mem...	Manu...	Resolution	Audio	Monitor Name
D1 (TPSOUT1)	LWR	1920x1080p60.00Hz	2chLPCM	Univ_HDMI_PCM	U1	N/A	N/A	N/A	N/A
D2 (TPSOUT2)	LWR	1920x1080p60.00Hz	2chLPCM	Univ_HDMI_PCM	U2	N/A	N/A	N/A	N/A
D3 (HDMIOUT3)	SAM	1920x1080p60.00Hz	2chLPCM	T24B301	U3	N/A	N/A	N/A	N/A
D4 (HDMIOUT4)	LWR	1920x1080p60.00Hz	2chLPCM	Univ_HDMI_PCM	U4	N/A	N/A	N/A	N/A
D5 (HDMIAUDIOIN)	SAM	1920x1080p60.00Hz	2chLPCM	T24B301	U5	N/A	N/A	N/A	N/A
					U6	N/A	N/A	N/A	N/A
					U7	N/A	N/A	N/A	N/A
					U8	N/A	N/A	N/A	N/A
					U9	N/A	N/A	N/A	N/A
					U10	N/A	N/A	N/A	N/A
					U11	N/A	N/A	N/A	N/A
					U12	N/A	N/A	N/A	N/A
					U13	N/A	N/A	N/A	N/A
					U14	N/A	N/A	N/A	N/A
					U15	N/A	N/A	N/A	N/A
					U16	N/A	N/A	N/A	N/A
					U17	N/A	N/A	N/A	N/A
					U18	N/A	N/A	N/A	N/A
					U19	N/A	N/A	N/A	N/A
					U20	N/A	N/A	N/A	N/A
					U21	N/A	N/A	N/A	N/A
					U22	N/A	N/A	N/A	N/A
					U23	N/A	N/A	N/A	N/A

EDID Menu

Control buttons

	Export	Exporting an EDID (save to a file)		Executing EDID emulation or copying (Transfer button)
	Import	Importing an EDID (load from a file)		Deleting EDID (from User memory)
	Info	Display EDID Summary window		Selecting all memory places in the right panel
	Edit	Opening Advanced EDID Editor with the selected EDID		Selecting none of the memory places in the right panel
	Create	Opening Easy EDID Creator		

5.9.1. Sources and Destinations

The EDID memory consists of four parts:

- **Factory** EDID list shows the pre-programmed EDIDs (F1-F149).
- **Dynamic** EDID list shows the display device connected to the device's outputs. The unit stores the last display devices' EDID on either output, so there is an EDID shown even if there is no display device attached to the output port at the moment.
- **User memory** locations can be used to save custom EDIDs.

In MMX8x4-HT400MC and MMX8x4-HT420M models: (U1 – U27)

In MMX8x8-HDMI-4K-A model: (U1 – U24)

- **Emulated** EDID list shows the currently emulated EDID for the inputs. The source column displays the memory location that the current EDID was routed from.

The source reads the EDID from the Emulated EDID memory on the INPUT port. Any EDID from any of the User/Factory/Dynamic EDID lists can be copied to the user memory.

There are two types of emulation: **static** and **dynamic**.

- **Static EDID emulation:** an EDID from the Factory or User EDID list is selected. Thus, the Emulated EDID remains the same until the user emulates another EDID.
- **Dynamic EDID emulation:** it can be enabled by selecting D1-D4 EDID memory. The attached monitor's EDID is copied to the input; if a new monitor is attached to the output, the emulated EDID changes automatically.

5.9.2. EDID Operations

Changing Emulated EDID

- Step 1.** Choose the desired **EDID list** on the source panel and select an EDID.
- Step 2.** Press the **Emulated** button on the top of the Destination panel.
- Step 3.** Select the desired port on the right panel (one or more ports can be selected); the EDID(s) will be highlighted with a yellow cursor.
- Step 4.** Press the **Transfer** button to change the emulated EDID.

Learning an EDID

The process is the same as changing the emulated EDID; the only difference is the Destination panel: press the **User** button. Thus, one or more EDIDs can be copied into the user memory either from the factory memory or from a connected sink (Dynamic).

Exporting an EDID

ATTENTION! This function is working on Windows and macOS operating systems and under Firefox or Chrome web browsers only.

Source EDID can be downloaded as a file (*.bin, *.dat or *.edid) to the computer.

- Step 1.** Select the desired **EDID** from the **Source panel** (highlighted with a yellow cursor).
- Step 2.** Press the **Export** button to open the dialog box and **save** the file to the computer.

Importing an EDID

Previously saved EDID (*.bin, *.dat or *.edid file) can be uploaded to the **user memory**:



Step 1. Select the **User** tab in the left panel and select a memory slot.

Step 2. Press the **Import** button below the Source panel.

Step 3. Browse the file in the opening window then press the **Open** button. Browsed EDID is imported into the selected User memory.

ATTENTION! The imported EDID overwrites the selected memory place even if it is not empty.

Deleting EDID(s)

The EDID(s) from User memory can be deleted as follows:



Step 1. Select the **User** tab in the left panel.

Step 2. Select the desired memory slot(s); one or more can be selected (**Select all** and **Select None** buttons can be used). The EDID(s) will be highlighted with yellow.

Step 3. Press the **Deleted selected** button to delete the EDID(s).

5.9.3. EDID Summary Window

Select an EDID from Source panel and press the **Info** button to display EDID summary.

General	
EDID version:	1
EDID revision:	4
Manufacturer ID:	LWR (Lightware Visual Engineering)
Product ID:	0000
Monitor serial number:	Not present
Year of manufacture:	2010
Week of manufacture:	Not Used
Signal interface:	Digital
Separate Sync H&V:	-
Composite sync on H:	-
Sync on green:	-
Serration on VS:	-
Color depth:	Undefined
Interface standard:	HDMI-a is supported
Color spaces:	RGB 4:4:4 & YCrCb 4:4:4
Aspect ratio:	0
Display size:	0 cm X 0 cm

5.9.4. Editing an EDID

Select an EDID from the left panel and press the **Edit** button to display Advanced EDID Editor window. The editor can read and write all descriptors, which are defined in the standards, including the additional CEA extension. Any EDID from the device's memory or a saved EDID file can be loaded into the editor. The software resolves the raw EDID and displays it as readable information to the user. All descriptors can be edited, and saved in an EDID file, or uploaded to the User memory. For more details about EDID Editor please visit our website (www.lightware.com) and download the EDID Editor User's Manual.

Basic EDID	
Vendor / Product Information	
Display Parameters	
Power Management and Features	
Gamma / Color and Established Timings	
Standard Timings	
Preferred Timing Mode	
2nd Descriptor Field	
3rd Descriptor Field	
4th Descriptor Field	
CEA Extension	
General	
Video Data	
Audio Data	
Speaker Allocation Data	
HDMI VSDB	
HDMI Forum VSDB	
YCbCr 4:2:0 VDB	
YCbCr 4:2:0 Capability Map	
Colorimetry	
High Dynamic Range	
Detailed Timing Descriptor #1	
Detailed Timing Descriptor #2	
Detailed Timing Descriptor #3	
Detailed Timing Descriptor #4	
Detailed Timing Descriptor #5	
Detailed Timing Descriptor #6	
Save EDID	

EDID Byte Editor										
	0	1	2	3	4	5	6	7	8	9
0	00	FF	FF	FF	FF	FF	FF	00	1E	6D
10	08	5B	40	72	05	00	03	1B	01	03
20	80	3C	22	78	EA	30	35	A7	55	4E
30	A3	26	0F	50	54	21	08	00	71	40
40	81	80	81	C0	A9	C0	D1	C0	81	00
50	01	01	01	01	04	74	00	30	F2	70
60	5A	80	B0	58	8A	00	58	54	21	00
70	00	1E	56	5E	00	A0	A0	A0	29	50
80	30	20	35	00	58	54	21	00	00	1A
90	00	00	00	FD	00	38	3D	1E	87	1E
100	00	0A	20	20	20	20	20	20	00	00
110	00	FC	00	4C	47	20	55	6C	74	72
120	61	20	48	44	0A	20	01	D2		

EDID Editor Window

5.9.5. Creating an EDID

Since above mentioned Advanced EDID Editor needs more complex knowledge about EDID, Lightware introduced a wizard-like interface for fast and easy EDID creation. With Easy EDID Creator it is possible to create custom EDIDs in four simple steps. By clicking on the **Create** button below the left panel, Easy EDID Creator is opened in a new window.

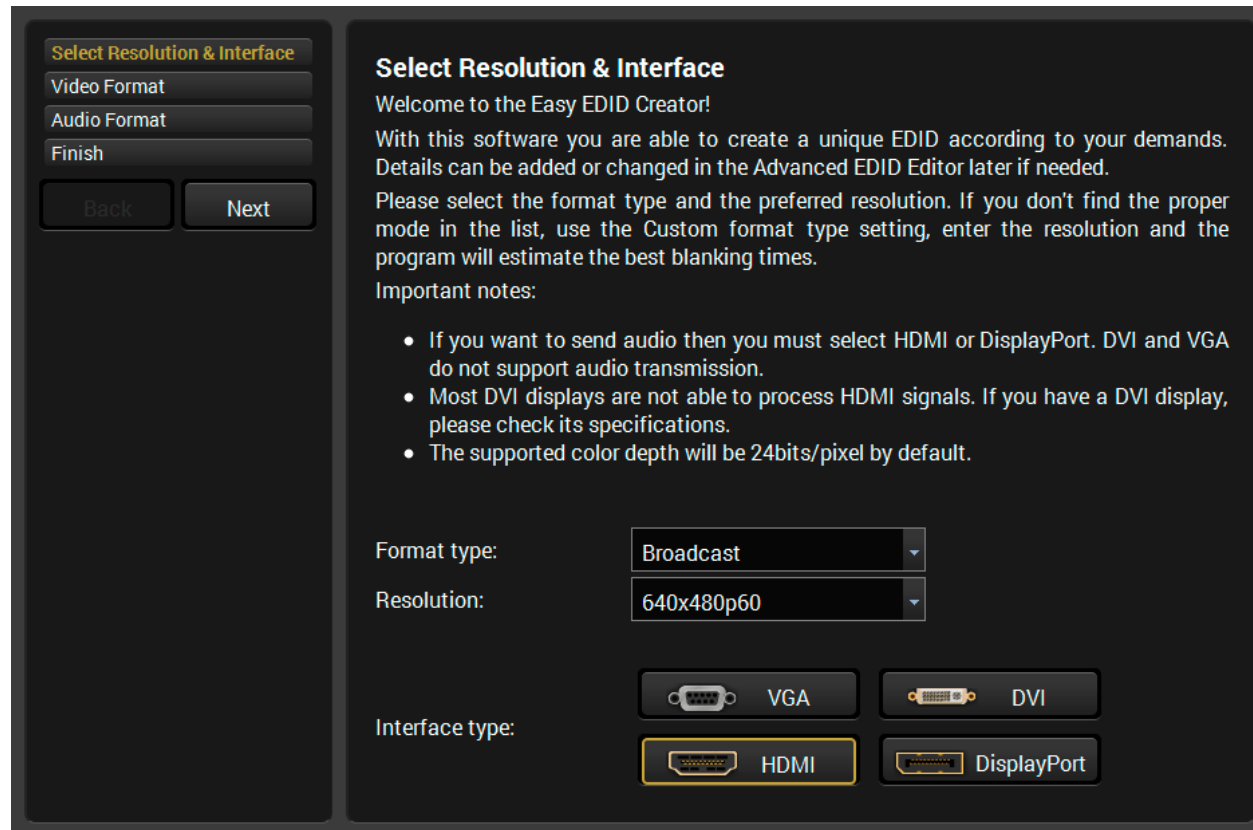

Easy EDID Creator Wizard

5.10. Control Menu

The menu gives the opportunity to set the interfaces which can be used to connect or control third party devices.

5.10.1. RS-232 Tab

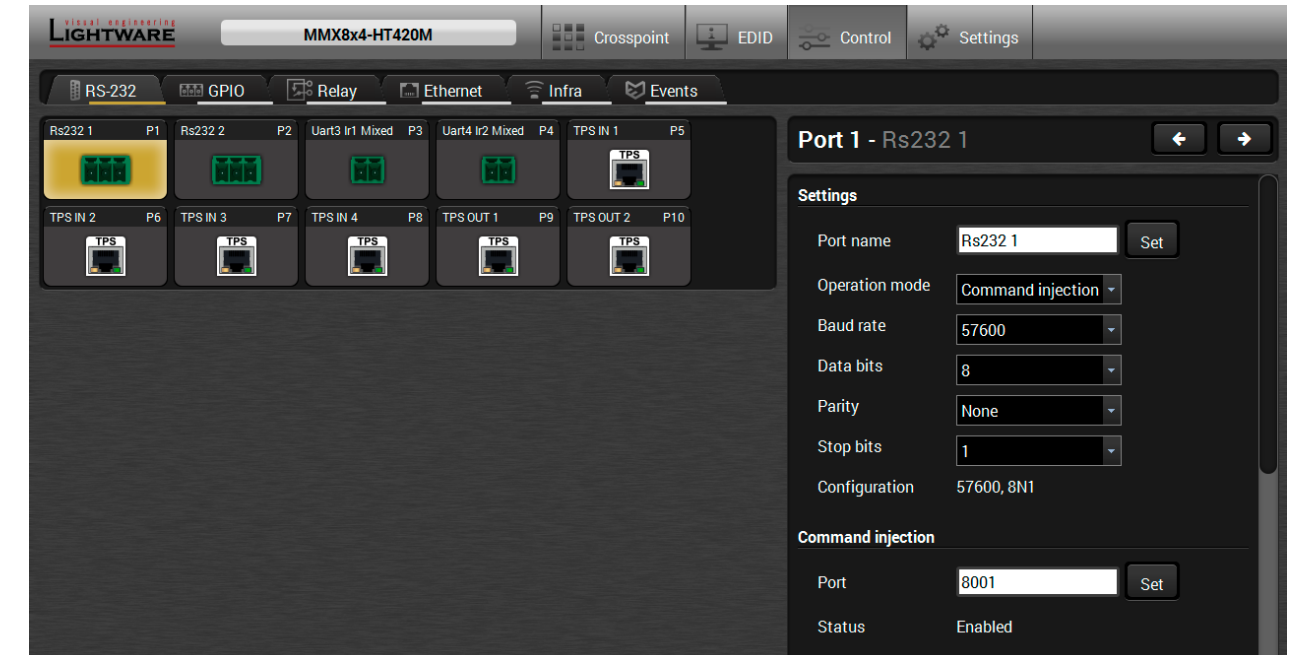

RS-232 Tab in Control menu in MMX8x4-HT420M model

RS-232 data transmission runs three different interface:

- **P1, P1** channels are for bidirectional RS-232 communication. Disconnected, Control and Command Injection operation modes are available.
- **P2, P3** channels can be TTL serial ports or Infra ports depending on the transmitted data protocol. This port is able to transmit a unidirectional data flow, for example forwarding the serial messages or Infra messages, which come from the Control Ethernet port (in this case the operation mode is always Command Injection). Sending serial or infra message is also possible.
- TPS channels* are able to send and receive serial data, so **P4-P10** ports can operate in Disconnected, Control and Command Injection mode.

*In MMX8x4-HT400MC and MMX8x4-HT420M models.

The following settings and functions are also available:

- Port name
- Baud rate: 4800, 7200, 9600, 14400, 19200, 38400, 57600, 115200;
- Data bits: 8 or 9;
- Parity: None, Odd, or Even;
- Stop bits: 1, 1.5, or 2;
- Command injection port number;
- Control protocol: LW2 or LW3;
- Message sending
- Reloading factory defaults (see factory default settings in the Factory Default Settings section).

5.10.2. Ethernet

CPU (P1) and Control Ethernet (P2) ports are displayed on this tab.

In MMx8x4-HT420M model there are more ports as it is seen on the picture below:

- Ethernet Link TPS Out (P3)
- Ethernet Link TPS In (P4)
- TPS IN 1-4 (P5-8)
- TPS OUT 1-2 (P9-P10)

The Ethernet ports display the status of the Ethernet, speed, and the duplexity of the connection.

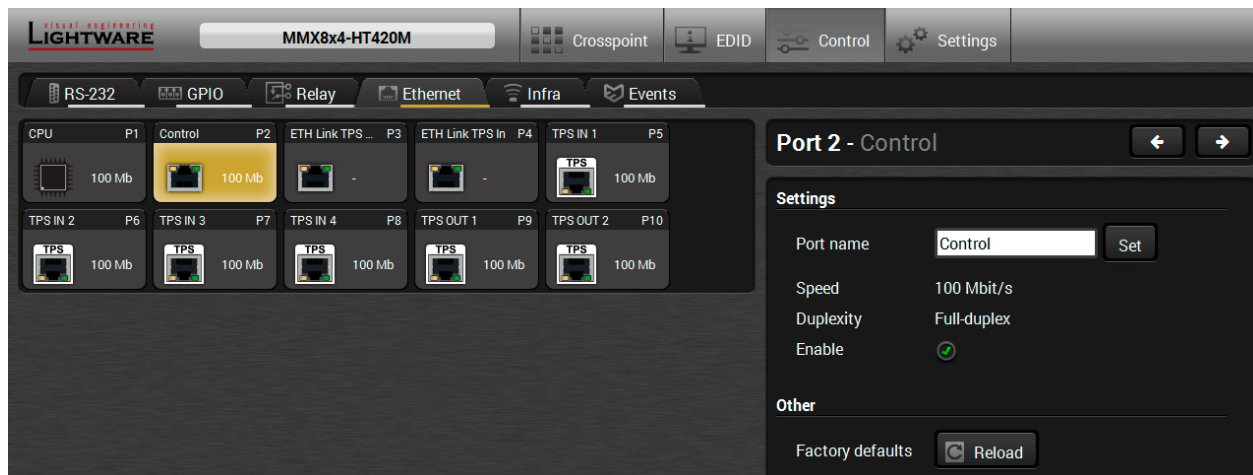

Ethernet tab in Control menu in MMX8x4-HT420M model

The following settings are also available:

- Port name
- Enable / disable the port (for loop protection);
- Reloading factory defaults (see factory default settings in the Factory Default Settings section).

ATTENTION! If the Ethernet port is set to disabled, this may break the connection with the device.

INFO: CPU Ethernet port can not be disabled.

5.10.3. Infra Tab

ATTENTION! The device has no built-in Infrared transmitter. For the complete usage attach an IR emitter unit to the IR OUT connector.

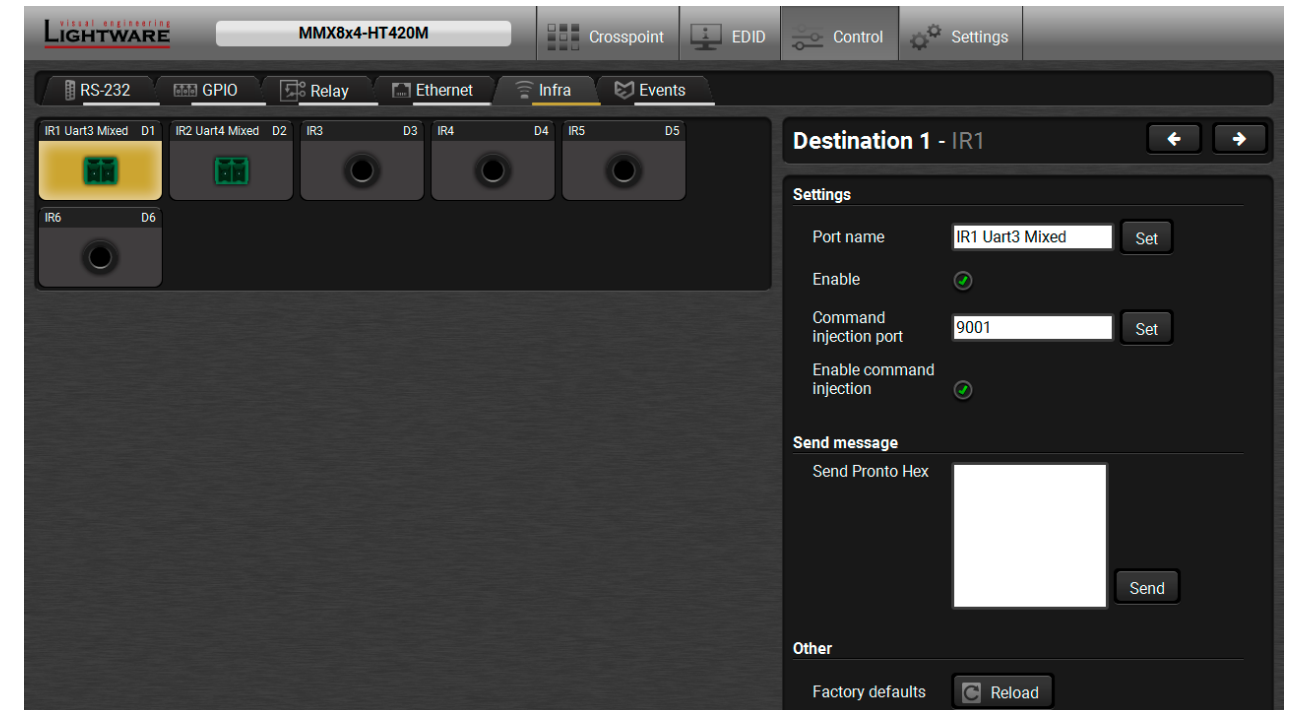

Infra tab in Control menu in MMX8x4-HT420M model

All the infra ports are transmitters and they are able to forward the Infra message, which comes from the Control Ethernet port (the operation mode is always Command Injection).

The following settings are also available:

- Port name
- Enable / disable the port;
- Port number
- Enable / disable command injection
- Message sending function (little-endian prontohex code) For more details see the [Sending Little-endian format pronto hex codes](#) section.
- Reloading factory defaults (see factory default settings in the [Factory Default Settings](#) section).

5.10.4. GPIO Tab

INFO: Only MMX8x4-HT420M model has GPIO port.

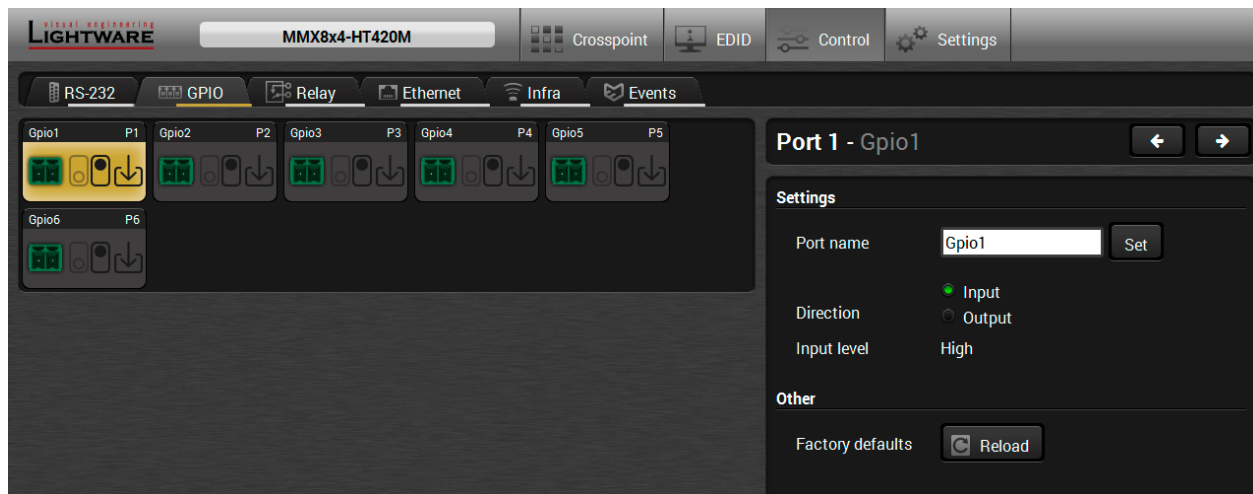

GPIO tab in Control menu in MMX8x4-HT420M model

The GPIO port has 7 pins, which operate at TTL digital signal levels and can be controlled by LDC or protocol commands. Select a GPIO pin and under the Port settings section; the settings (pin direction and input level) are displayed on the port tiles as well:

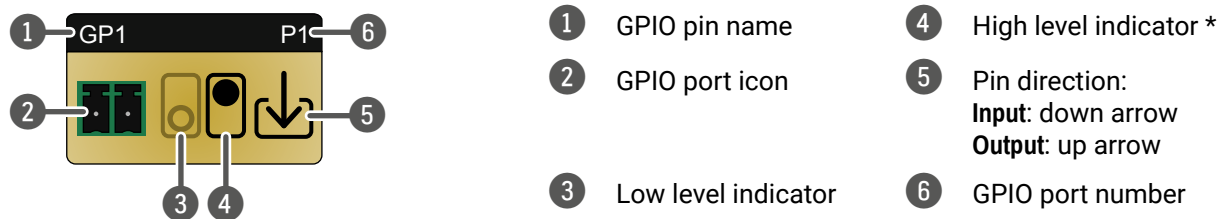

* Highlighted with black means the current setting.

INFO: Output level can be set only in case of setting the pin direction to Output. In case of input direction the output level setting and the Toggle button is not available.

For more details see the [GPIO Interface](#) section.

5.10.5. Relay Tab

INFO: Only MMX8x4-HT420M model has Relay port.

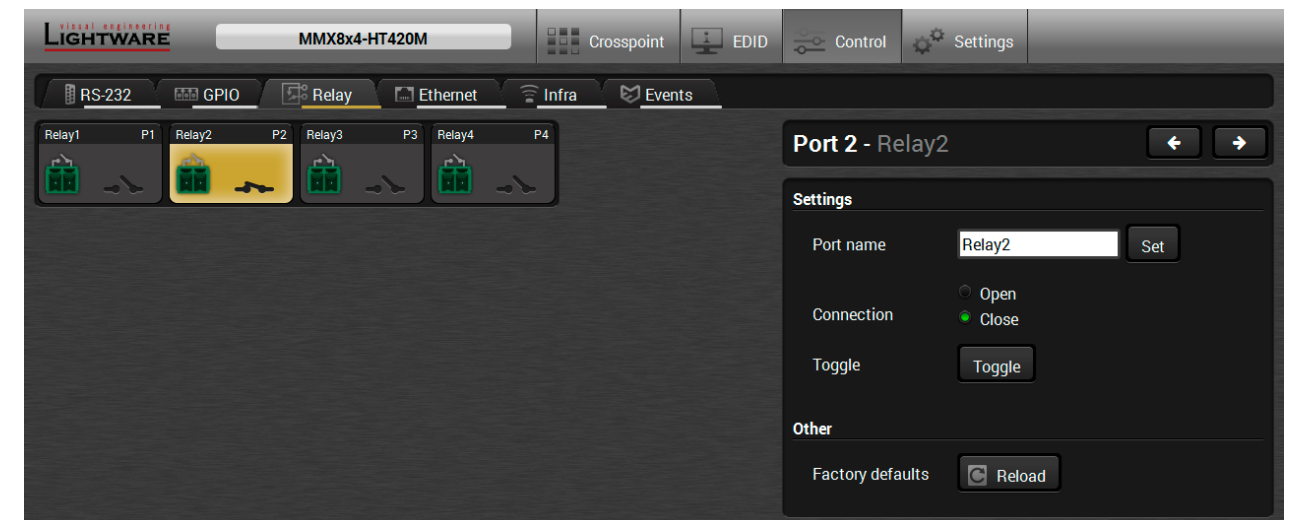

Relay tab in Control menu in MMX8x4-HT420M model

Four relays are built into the matrix switcher. The following settings are available:

- Port name
- Connection state (Open / Close)
- Toggle;
- Reloading factory defaults (see factory default settings in the [Factory Default Settings](#) section).

For more details see the [Relay Interface](#) section.

5.11. Event Manager

The feature means that the device can sense changes on its ports and able to react according to the pre-defined settings. The development idea of the Event manager is based on users' feedbacks. In many cases internal events (such as signal present or HDCP active) are necessary to display but it is not easy when the device is hard to access (e.g. built under the desk).



The Event manager can be configured to perform an action if a condition has been detected. E.g. the desired setup is that after a certain type of signal has been detected on I1 port, the port has to be switched to O1. The settings can be done via the LDC in the Control/Events tab, or by LW3 protocol commands. Configurable events number depends on the device what you are using actually.

Numerous new ideas and requests have been received in connection with the features and settings of the Event manager since the first release. Therefore, the user interface has been re-designed and many new functions implemented. The Event editor can be opened by pressing the **Edit** button at each Event.

There is a **grey bar** on the left of the Event panel in each line. If a condition and an action are set and the Event is enabled, the bar is displayed in **green**.

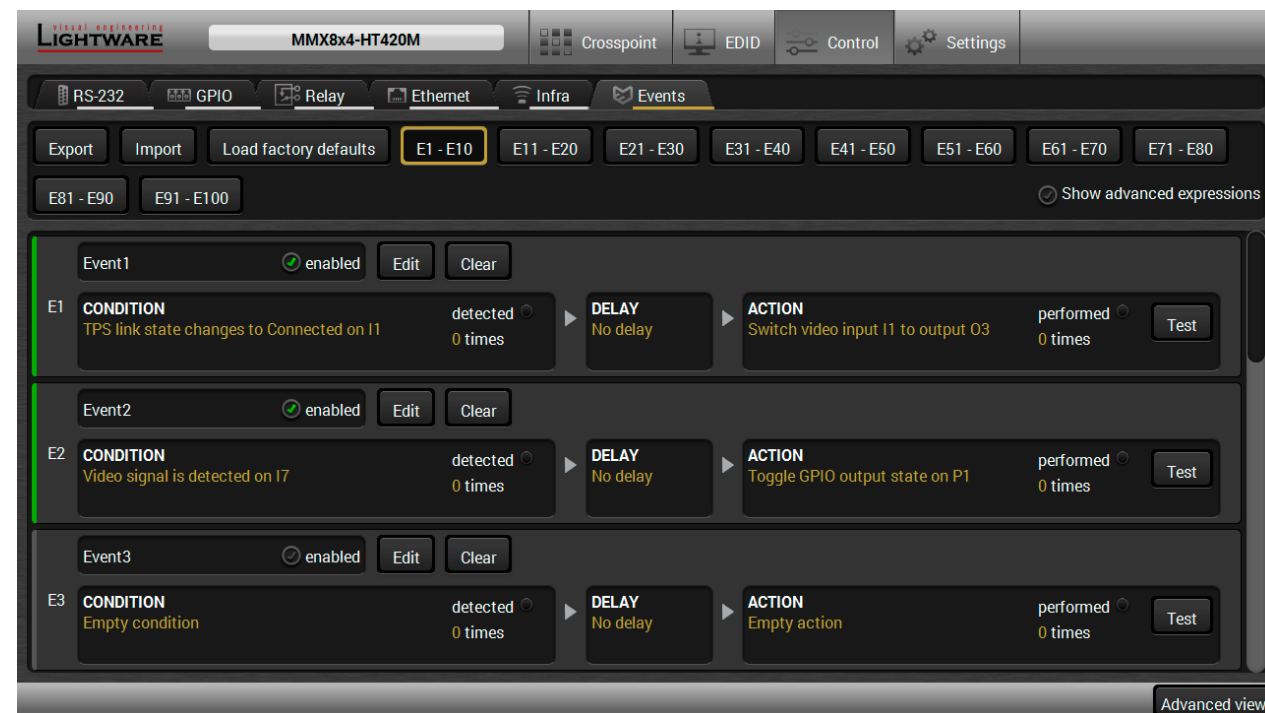

Control menu, Event Manager tab

5.11.1. The Event Editor

Press the **Edit** button in the desired Event line to open the Event editor window.

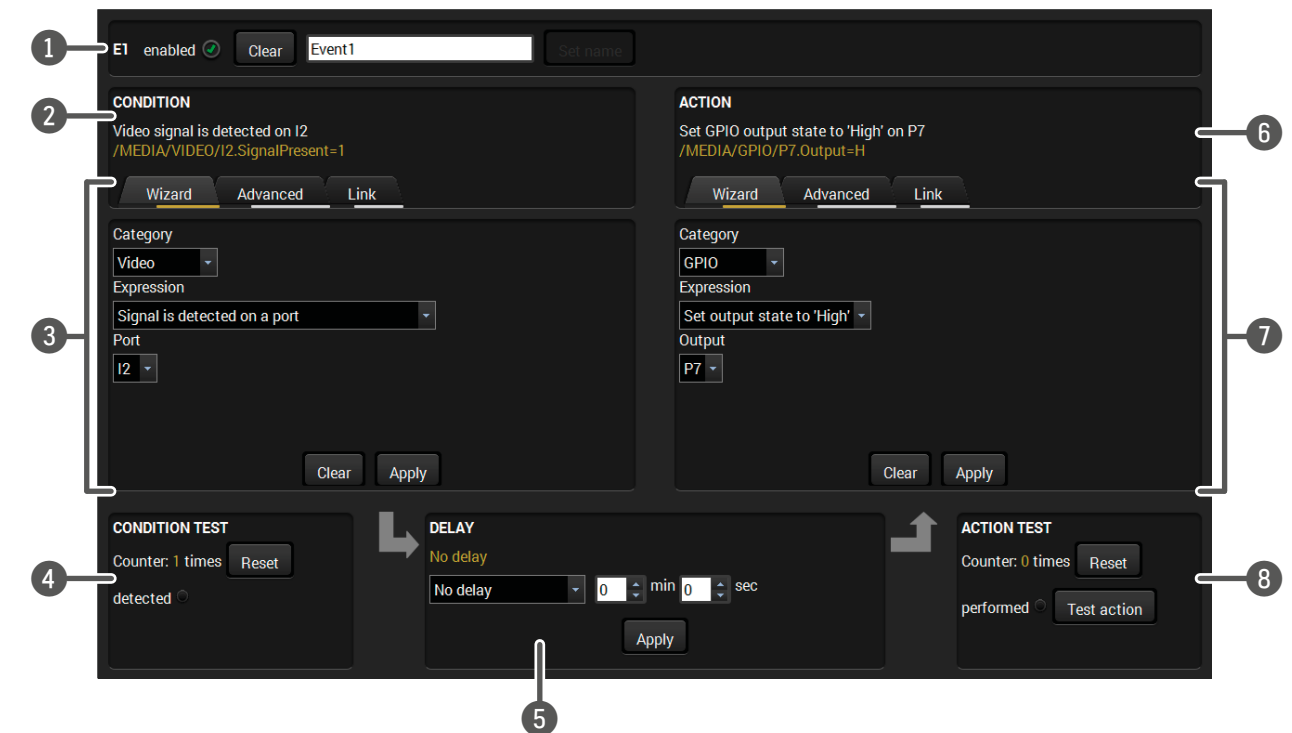

- 1 **Event header** The name of the Event is displayed. Type the desired name and press the Set name button. The Event can be cleared by the Clear button. Use the tick mark to enable/disable the Event.
- 2 **Condition header** If the condition is set, the description (white colored text) and the exact LW3 protocol expression (yellow colored text) can be seen. If the advanced mode was used the description is "Custom condition".
- 3 **Condition panel** The Wizard, the Advanced or the Link tool is available to set the condition. The parameters and settings are displayed below the buttons.
- 4 **Condition test** The set condition can be tested to see the working method in the practice.
- 5 **Delay settings** The action can be scheduled to follow the condition after the set time value.
- 6 **Action header** If the action is set, the description (white colored text) and the exact LW3 protocol expression (yellow colored text) can be seen. If the advanced mode was used the description is "Custom action".
- 7 **Action panel** The Wizard, the Advanced or the Link tool is available to set the action. The parameters and settings are displayed below the buttons.
- 8 **Action test** The set action can be tested to see the working method in the practice.

5.11.2. Create or Modify an Event

Wizard Mode

The wizard mode lists the most common conditions and actions, so the user does not have to look for LW3 nodes and properties.

- Step 1.** Click on the **Edit** button of the desired Event; the **Event editor** is displayed.
- Step 2.** The wizard mode is displayed as default. Select the desired **Category** first (e.g. Audio or Video).
- Step 3.** Select the desired **Expression** from the drop-down menu. If any other parameter is necessary to set, it is going to be displayed.
- Step 4.** Press the **Apply** button to store the settings of the Condition.

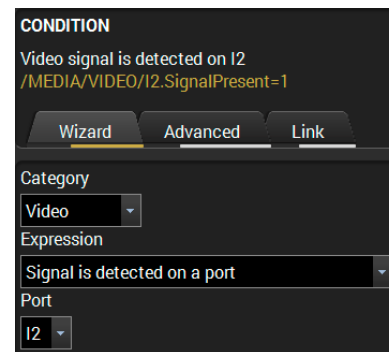

Advanced Mode

The goal of this mode is the same as of the wizard: set the properties and methods for conditions and actions. The difference is the number of the available and usable properties and methods of the LW3 protocol. Advanced mode allows almost all of it.

- Step 1.** Click on the **Edit** button of the desired Event; the **Event editor** is displayed.
- Step 2.** The wizard mode is the default, press the **Advanced** button. The LW3 protocol tree is displayed showing the list of the properties in the drop-down menu. Navigate to the desired node.
- Step 3.** Select the desired **Property** from the menu. The **manual** of the property is displayed below to help to select the necessary property and to set the value.
- Step 4.** Set the desired **value** and **operator**, then press the **Apply** button to store settings.

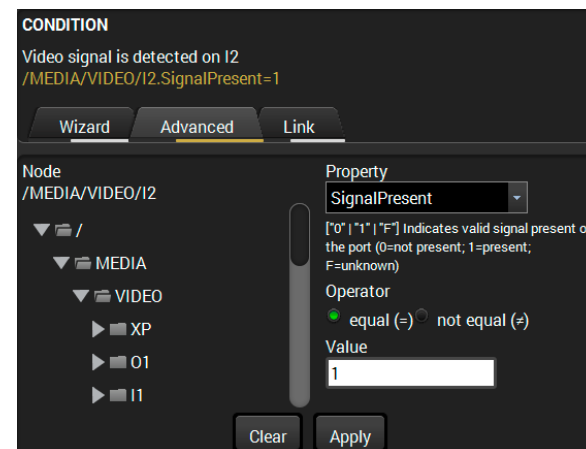

The Link Tool

The new interface allows creating more actions to the same condition. In that case, a condition can trigger more actions. To set such an Event, the Link tool has been introduced.

- Step 1.** Click on the **Edit** button of the desired Event; the **Event editor** is displayed.
- Step 2.** The wizard mode is displayed as default, press the **Link** button.
- Step 3.** All the saved Events are analyzed and the **conditions** are listed (it takes some seconds to finish). The **Show advanced expressions** option allows showing

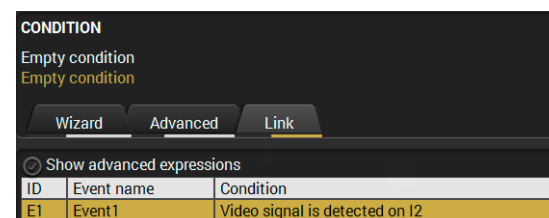

the exact path and set the value of the given property.

- Step 4.** Select the desired **Condition** and press the **Apply** button to store the settings.

5.11.3. Special Tools and Accessories

The Name of the Event

The name of a port can be changed by typing the new name and clicking the **Set** button. The following characters are allowed when naming:

Letters (A-Z) and (a-z), numbers (0-9), special characters: hyphen (-), underscore (_), and space ().

Enable or Disable an Event

The set Event can be enabled or disabled in the Event list, or directly in the Event editor window by setting the **tick mark** beside the name.

Testing the Condition

When the desired Condition is arranged, the setting can be tested. The Event list and the Event editor contains a small panel that shows if the set condition is detected and how many times. The **Counter** can be reset by the button in Event editor. If the Condition is true, the **detected** mark turns green for two seconds and the **Counter** is increased.

Testing the Action

The method is the same as testing the Condition, but in this case, the Action can be triggered manually by pressing the **Test** button.

TIPS AND TRICKS: The Test button is also placed on the Action panel in the Event list. Thus, you can check the Actions without opening the Event editor.

Delay the Action

In most cases the Action is performed immediately after the Condition is detected. But sometimes a delay is necessary between the Condition and the Action. Therefore, the new Event manager contains the Delay panel which allows that feature with below settings:

- **No delay:** when the Condition is detected, the Action is launched.
- **Simple delay:** when the Condition is detected, the Action is launched after the set time interval.
- **Still exists:** when the Condition is detected, the Action is launched after the set time interval only if the Condition still exists.
- **Continuously exists:** when the Condition is detected, the Action is launched after the set time interval only if the Condition has been existing continuously.

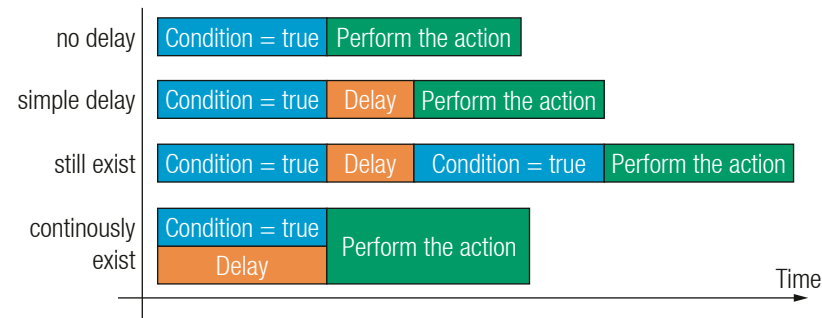

The available delay settings of an Event

TIPS AND TRICKS: **Show advanced expressions** option is a useful tool when you look for the path or value of a property but just the expression is displayed. The option is available in the Event list window or when Link tool is used.

5.11.4. Clear One or More Event(s)

Clear an Event

Press the **Clear** button in the Event list or in the header section in the Event editor.

Clear all Events

When all the Events must be cleared press the **Load factory defaults** button above the Event list. You will be prompted to confirm the process.

5.11.5. Export and Import Events

The feature allows saving all the Events. The backup file can be uploaded to another MMX8x8-HT series matrix.

Export all the Events

Step 1. Press the **Export** button above the Event list.

Step 2. The Save as dialog box will appear. Set the desired folder and file name, then press the **Save** button.

The generated file is a simple text file which contains LW3 protocol commands. The file can be viewed by a simple text editor, e.g. Notepad.

ATTENTION! Editing the file is recommended only for expert users.

Import all the Events

Step 1. Press the **Import** button above the Event list.

Step 2. The Open dialog box will appear. Select the desired folder and file, then press the **Open** button.

5.12. Settings Menu

5.12.1. Status

General information is shown on this tab, such as device label, part number, serial number and hardware health, voltage and temperature values.

Category	Parameter	Value
General	Product name	MMX8x4-HT420M
	MAC address	a8:d2:36:00:54:84
	Hardware version	V10_BAA0
	Device label	MMX8x4-HT420M <input type="button" value="Set"/>
	Part number	91310042
	Serial number	00005484
Operation	System uptime	0 days 03h 48m 34s
	Operation time	2 days 20h 19m 04s
	High temp operation time	0 days 01h 32m 55s
Firmware versions	CPU firmware version	0.0.255b255 r203
Temperatures	CPU temperature	54 °C (26 °C min, 82 °C max)
	System temperature	58 °C (26 °C min, 96 °C max)
	In temperature	58 °C (22 °C min, 96.66 °C max)
	Crosspoint temperature	47 °C (18 °C min, 82.4 °C max)
	Power supply temperature	56.19 °C (5.11 °C min, 62.99 °C max)
	Input board temperature	55 °C (3 °C min, 65 °C max)

Status tab in Settings menu

5.12.2. Network Tab

Network-related settings are available on the tab.

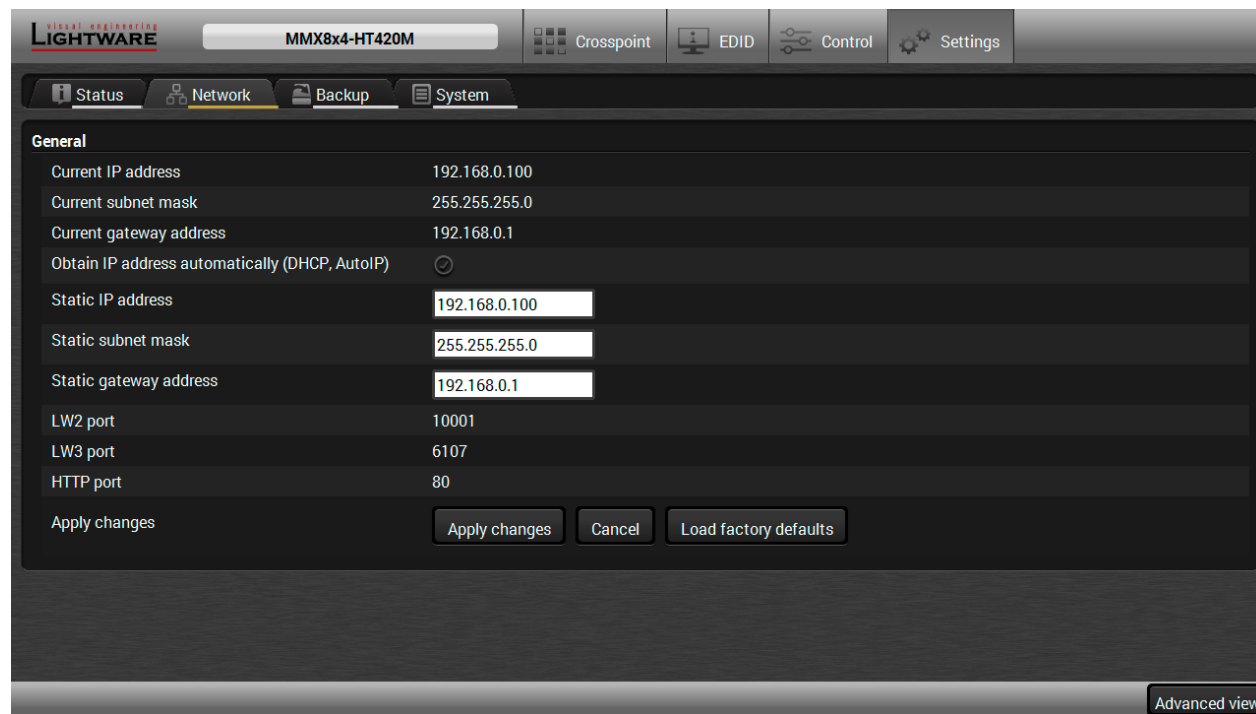

Network tab in Settings menu

5.12.3. Backup

Details about this function can be found in the [Configuration Cloning \(Backup Tab\)](#) section.

5.12.4. System

Three functions are available under System tab:

- **Download system log** - saving the file of the device.
- **Load factory defaults** - recalling factory defaults settings and values. All [Factory Default Settings](#) are listed in the section.
- **Reboot** - rebooting the system.

5.13. Configuration Cloning (Backup Tab)

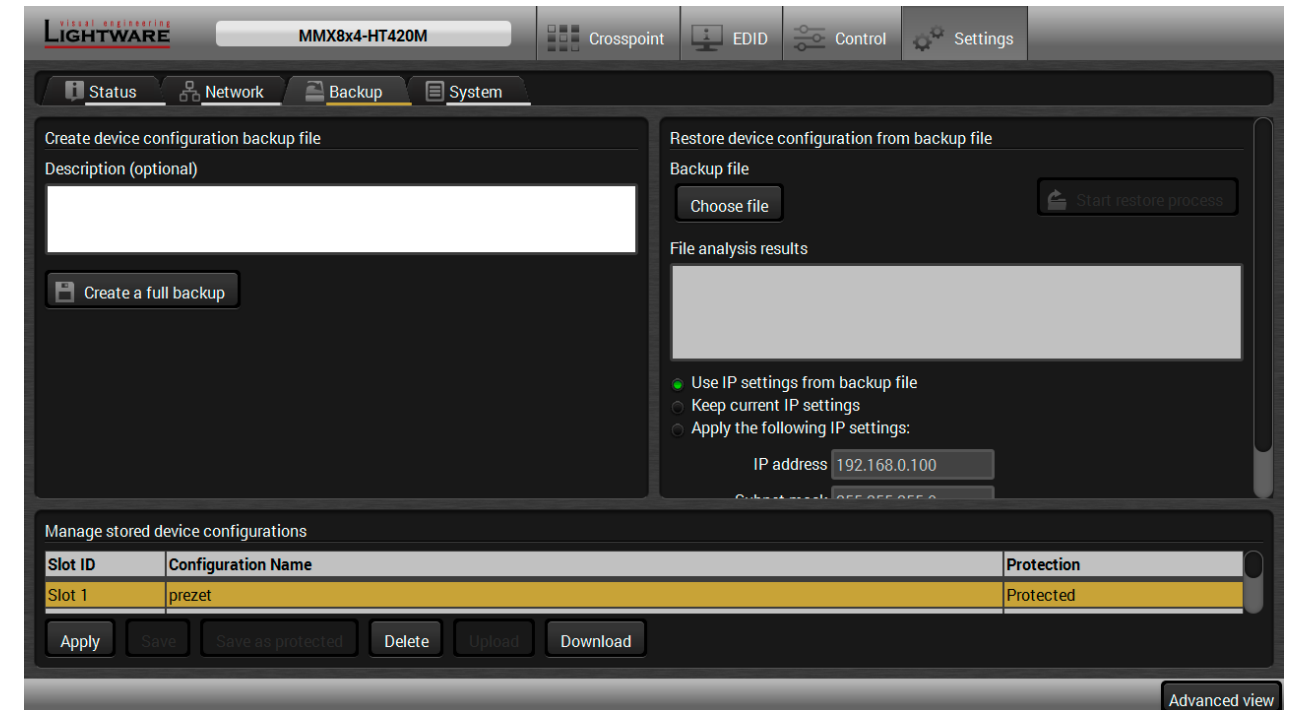

Backup tab in Settings menu

The configuration cloning of Lightware LW3 devices is a simple method that eliminates the need to repeatedly configure certain devices to have identical (non-factory) settings. If the devices are installed in the same type of system multiple times then it is enough to set up only one device to fit the user's needs and then copy those settings to the others, thus saving time and resources.

5.13.1. Cloning Steps in a Nutshell

Installing multiple devices with the same customized configuration settings can be done in a few easy steps:

Step 1. Configure one device with all your desired settings with the LDC software.

Step 2. Backup the full configuration file to your computer.

Step 3. If needed, make some modifications to the configuration file using a text editor (e.g. Notepad). E.g. modifying the static IP address is needed when DHCP is not used.

Step 4. Connect to the other device which has to be configured and upload (restore) your configuration file.

Step 5. Done! You can have as many totally identical, customized devices as you like.

5.13.2. Save the Settings of the Device (Backup)

- Step 1.** Apply the desired settings in the transmitter (port parameters, crosspoint, etc.)
- Step 2.** Select the Settings / Backup tab from the menu.
- Step 3.** Write a short description in the text box on the left (optional).
- Step 4.** Press the Create a full backup button. You will be prompted to save the file to the computer. The default file name is the following:

BACKUP_<DEVICE LABEL>_SN<SERIAL NUMBER>.LW3

- Step 5.** Set the desired file name, select the folder and save the file.

TIPS AND TRICKS: Using the exact product type in the filename is recommended since it makes the file usage more comfortable.

About the Backup File

The backup file is a simple text file which contains LW3 protocol commands. The first line is the description, and the further lines are the commands which will be executed during the restore process. The file can be viewed (and/or edited) by a simple text editor, e.g. Notepad.

ATTENTION! Editing the command lines is only recommended for expert users.

See the entire list of saved data in the Content of Backup File section.

5.13.3. Upload the Settings to a Device (Restore)

WARNING! Please note that the settings will be permanently overwritten with the restored parameters in the device. Withdrawal is not possible.

ATTENTION! The cloning is successful when the backup file is downloaded from the same type of source device as the destination device.

The Restoring Process

- Step 1.** Select the Settings / Backup tab from the menu.
- Step 2.** Click on the Choose file button on the right panel and browse the desired file.
- Step 3.** The file is checked and the result will be displayed in the textbox below. If the file is correct, the settings can be restored.
- Step 4.** Choose IP settings what you want to use after backup. You can apply settings from the backup file, keep actual settings, set it manually in a dialog box or apply DHCP.
- Step 5.** Press the Start restore process button and click on the Yes button when asked.
- Step 6.** Reboot the device to apply the network settings after finishing.

5.13.4. Create and Restore Backups from the Device Memory

MMX8x4 series matrix is able to store backups in its own memory and can be recalled from there so user does not need to save backup files to the local computer. Four slots are available for this purpose.

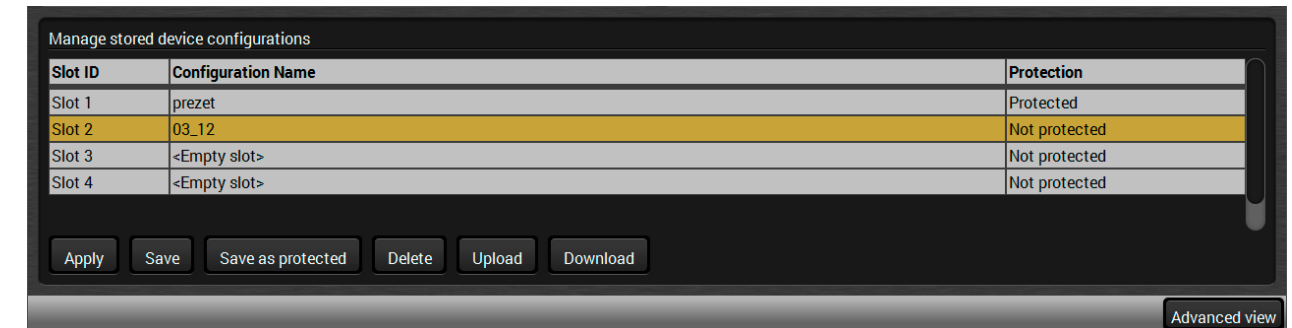

Slot ID	Configuration Name	Protection
Slot 1	prezet	Protected
Slot 2	03_12	Not protected
Slot 3	<Empty slot>	Not protected
Slot 4	<Empty slot>	Not protected

Buttons: Apply, Save, Save as protected, Delete, Upload, Download

Advanced view

You can save presets as not protected with using **Save** button and as protected with using the **Save as protected** button. Restoring a preset select on the slot of the desired backup and click on the **Apply** button. You can save presets from a file from your local computer clicking on the **Upload** button and you can also save a preset from the device's memory to a backup file with using the **Download** button. If you do not need a saved preset any more, select it and click on the **Delete** button.

WARNING! Loading factory default settings will erase all presets which has been saved in the device memory!

5.14. Advanced View

Advanced view is the surface for displaying the LW3 protocol tree. Commands and specific parameters (which are not available on the graphical user interface of the LDC) can be run and set by the controlling tools.

The screenshot shows the LW3 protocol tree interface. At the top, there are two status indicators: 'Enable editing' (checked) and 'Warn before enable editing' (checked). The interface is divided into several sections:

- 1 LW3 protocol help:** A button in the top left corner.
- 2 Terminal Window:** A large text area on the left displaying protocol commands and responses, such as 'pr /MEDIA/VIDEO.17=HDMI IN 7' and 'EDB5=GET /MEDIA/VIDEO/XP.*'.
- 3 Protocol Tree:** A tree view on the left showing the hierarchy of nodes: /, MEDIA, VIDEO, and XP. The XP node is expanded to show sub-nodes like I1, I2, I3, I4, I5, I6, I7, I8, O1, O2, O3, O4, O5, AUDIO, UART, IR, GPIO, RELAY, ETHERNET, EDID, MANAGEMENT, PRESETS, and REMOTE.
- 4 Edit Mode:** A checkbox in the top right, currently checked.
- 5 Node List:** A list of parameters for the selected node (/MEDIA/VIDEO/XP), including SourcePortCount, SourcePortStatus, DestinationPortCount, DestinationPortStatus, DestinationPortAutos..., AutoSelectionConne..., AutoSelectionDiscon..., PortPriorityList, PortGroupList, ModifiableConnectio..., ClickableConnection..., DestinationConnecti..., unlockSource, unlockDestination, unmuteSource, unmuteDestination, and setAutoselectionPrior... Each parameter has a text input field and a 'Manual' button.
- 6 Warn Option:** A checkbox in the top right, currently checked.
- 7 Command Line:** A text input field at the bottom left with 'Send', 'Clear', and 'Autoscroll' (checked) buttons.

- | | |
|--|---|
| <p>1 LW3 Protocol Help</p> <p>2 Terminal Window</p> <p>3 Protocol Tree</p> <p>4 Edit Mode</p> <p>5 Node List</p> <p>6 Warn Option</p> <p>7 Command Line</p> | <p>Short description about the command types and LW3 Protocol.</p> <p>Commands and responses. Sent command starts with ">" character, received response starts with "<" character. The content of the window can be emptied by the Clear button. If the Autoscroll option is ticked, the list is scrolled automatically when a new line is added. Place the mouse cursor on a line to display the date and time stamp in a Hint field.</p> <p>LW3 protocol tree; select an item to see its content.</p> <p>The default appearance is the Edit mode. If the option is unticked the values or parameters cannot be changed.</p> <p>Parameters and nodes of the selected item are shown.</p> <p>The LDC can be set to warn the user before enable the Edit mode.</p> <p>Type the desired command and execute it by the Send button.</p> |
|--|---|

6

LW2 Programmers' Reference

Lightware MMX8x4-HT family can be controlled with external devices which can communicate according to the extender protocol. The supported LW2 commands are described in this chapter.

- ▶ [LW2 PROTOCOL DESCRIPTION](#)
- ▶ [GENERAL LW2 COMMANDS](#)
- ▶ [PORT AND CROSSPOINT SETTINGS](#)
- ▶ [NETWORK CONFIGURATION](#)
- ▶ [GPIO SETTINGS](#)
- ▶ [RELAY SETTINGS](#)
- ▶ [LW2 COMMANDS – QUICK SUMMARY](#)

6.1. LW2 Protocol Description

The device accepts commands surrounded by curly brackets - { } - and responds data surrounded by round brackets - () - only if a command was successfully executed.

Format	Explanation
<in>	Input number in 1 or 2 digit ASCII format (01, 5, 07, 16, etc.)
<out>	Output number in 1 or 2 digit ASCII format
<in ² >	Input number in 2 digit ASCII format (01, 02, 10, 12 etc.)
<out ² >	Output number in 2 digit ASCII format (01, 02, 10, 12 etc.)
<loc>	Location number in 1, 2 or 3 digit ASCII format
<id>	id number in 1 or 2 digit ASCII format
<id ² >	id number in 2 digit ASCII format
CrLf	Carriage return, Line feed (0x0D, 0x0A)
•	Space character (0x20)
→	Each command issued by the controller
←	Each response received from the router

6.2. General LW2 Commands

6.2.1. View Product Type

Description: The device responds its name.

Format	Example
Command {i}	→ {i}
Response (<PRODUCT_TYPE>CrLf	← (I:MMX8x4-HT420M)CrLf

Explanation: The connected device is an MMX8x4-HT420M.

Legend: <PRODUCT_TYPE> shows type.

6.2.2. View Serial Number

Description: The device responds its 8-digit serial number.

Format	Example
Command {s}	→ {s}
Response (SN:<SERIAL_N>)CrLf	← (SN:00005484)CrLf

6.2.3. Query Device Label

Description: The device responds its label.

Format	Example
Command {LABEL=?}	→ {LABEL=?}
Response (LABEL=DEVICE_LABEL>)CrLf	← (LABEL=MMX8x4-HT420M)CrLf

6.2.4. Query Control Protocol

Description: The device can be controlled with different control protocols. This command queries the active protocol of the currently used control interface.

Format	Example
Command {P_?}	→ {P_?}
Response (CURRENT●PROTOCOL●=#<protocol>)CrLf	← (CURRENT PROTOCOL = #1)CrLf

Explanation: The device communicates with LW2 protocol.

6.2.5. View Firmware Version of the CPU

Description: View the CPU firmware revision.

Format	Example
Command {f}	→ {f}
Response (FW:<FW_VER><s>)CrLf	← (FW:1.0.0b15 r17)<CR><LF>

Legend: <FW_VER> is the firmware version. It is followed by <s> string which may indicate special versions. <s>=r indicates standard version.

6.2.6. Connection Test

Description: Simple test to see if the connection is established successfully.

Format	Example
Command {PING}	→ {ping}
Response (PONG!)CrLf	← (PONG!)CrLf

6.2.7. Compile Time

Description: Returns the date, when the microcontroller firmware was compiled.

Format	Example
Command {CT}	→ {ct}
Response (Complied: <DATE&TIME>)CrLf	← (Compiled: Apr 6 2018 13:26:40)<CR><LF>

6.2.8. View Installed Board(s)

Description: Shows the hardware name and revision of the installed boards.

Format	Example
Command {is}	→ {is}
Response (SL#●0●<MB_DESC>)CrLf (SL●END)CrLf	← (SL# 0 Mmx8x4-Mb8) ← (SL# 1 MMX8X4-CONN Right) (SL# 2 MMX8X4-CONN Left) (SL# 3 MX-4TPS2-4HDMI-IB) (SL# 4 MX-HDMI-3D-STEREO-ADDON) (SL# 5 MX-HDMI-3D-STEREO-ADDON) (SL# 6 MX-4TPS2-4HDMI-OB) (SL# 7 MMX8X4-BASIC-MIC-ADDON) (SL# 8 DCM-G3) (SL END)<CR><LF>

Explanation: The device reports its motherboard (slot 0).

6.2.9. View Firmware for all Controllers'

Description: Shows the firmware versions of all installed controllers.

Format	Example
Command {FC}	→ {fc}
Response (CF●<DESC>)CrLf (CF●<DESC>)CrLf ... (CF END)CrLf	← (CF MMX8x4-HT420M 1.0.0b15 r17)<CR><LF> ← (CF END)<CR><LF>

Explanation: The device has one control panel.

6.2.10. Restart the Matrix Router

Description: The device can be restarted without unplugging power.

Format	Example
Command {RST}	→ {RST}
Response	←

Explanation: The device reboots; no response is sent in this case.

6.2.11. Query Health Status

Description: Queries health status. The response depends on the frame type.

Format	Example
Command {ST}	→ {st}
Response (ST•<DESC>)CrLf	← (ST CPU 5.14V 3.38V 57.29C 63.30C 63.00C 51.05C 62.74C 63.25C 58.44C)CrLf

Explanation: Internal voltages, temperature and fan speeds shown.

6.2.12. Restore Factory Default Settings

Description: Settings can be reset to factory default values as follows:

Format	Example
Command {FACTORY=ALL}	→ {factory=all}
Response (FACTORY ALL...)CrLf	← (FACTORY ALL...)CrLf

Explanation: All settings and parameters are reset to factory default, see the table in [Factory Default Settings](#) section.

6.3. Port and Crosspoint Settings

6.3.1. Switch One Input to One Output

Description: Switch input <in> to output <out>.

Format	Example
Command {<in>@<out>}	→ {2@1}
Response (O<out?>•I<in?>)CrLf	← (001 I02)CrLf

Explanation: Input 1 is switched to output 2.

ATTENTION! The response of this command does not show if the output is muted. To check the mute status a separate query has to be used like {VC}. See [View Connection State on the Output](#) section. To achieve multiple switches executed together, see [Batch Switch Outputs](#) section.

6.3.2. Switch One Input to All Output

Description: Switch input <in> to all outputs.

Format	Example
Command {<in>@0}	→ {2@0}
Response (I<in?>•ALL)CrLf	← (I02 ALL)

Explanation: Input 2 is switched to all outputs.

6.3.3. Mute Specified Output

Description: Mute output <out>. The output signal is turned off.

Format	Example
Command {#<out>}	→ {#01}
Response (1MT<out?>)CrLf	← (1MT01)CrLf

Explanation: 01 port is muted.

ATTENTION! Muting does not change the crosspoint's state but disables the output itself. This way the last connection can be easily restored with an unmute command. Switching a muted output does not unmute the output.

6.3.4. Unmute Specified Output

Description: Unmute output <out>.

Format	Example
Command {+<out>}	→ {+01}
Response (0MT<out?>)CrLf	← (0MT01)CrLf

Explanation: 01 port is unmuted.

INFO: Unmuting an output makes the previous connection active as the crosspoint's state has not been changed with the muting command, only the output was disabled.

6.3.5. Lock the Output

Description: Lock output <out>. Output's state cannot be changed until unlocking

Format	Example
Command {#><out>}	→ {#>01}
Response (1LO<out?>)CrLf	← (1LO01)CrLf

Explanation: 01 port is locked.

6.3.6. Unlock the Output

Description: Unlock output <out>. The connection on output can be changed.

Format	Example
Command {+<<out>}	→ {+<01}
Response (0LO<out?>)CrLf	← (0LO01)CrLf

Explanation: Output 1 is unlocked.

INFO: The device issues the above response regardless of the previous state of the output (either it was locked or unlocked).

6.3.7. View Connection State on the Output

Description: Viewing the output's connection results in different response length, because it depends on the device. The response below refers to an MMX8x4-HT420M.

Format	Example
Command {VC}	→ {vc}
Response (ALL●<O1>●<O2>●<O3>●<O4>)CrLf	← (ALL 02 02 02 M02 02)CrLf

Legend: All <Ox> indexes show the corresponding output's connection state. If value <O1> equals 02 it means that output 1 is connected to input 2. All <Ox> indexes are two digit ASCII characters (01, 02, 04, etc.). **State letters**

Letter	State	Example
L	Output is locked	L01
M	Output is muted	M01
U	Output is locked and muted	U01

Explanation: I2 is switched to II outputs.

6.3.8. View Crosspoint Size

Description: Shows the physical crosspoint size.

Format	Example
Command {getsize}	→ {getsize}
Response (SIZE=<size>)CrLf	← (SIZE=8x5)CrLf

Explanation: The device reports that it has a video crosspoint with 8 inputs and 5 outputs.

INFO: IN MMX8x4-HT400MC and MMX8x4-HT420M models five outputs means four video and one independent analog audio outputs).

6.3.9. Batch Switch Outputs

Description: The device is capable of switching multiple outputs exactly at the same time. To do this, the normal switch commands have to be used. If the switch commands arrive at the device with less than 10 milliseconds delay, the commands are collected and changes the output connections together.

Required circumstances:

- Switch commands have this format: {<in>@<out>}{<in>@<out>}
- The delay between two '}' characters must be below 10 milliseconds
- No other command or junk character is allowed between switch commands
- Affected outputs must not be locked

If any of the above circumstances fail, then the commands will be processed separately and the output connections will change one by one.

ATTENTION! The delay timeout applies for the receiving time of characters. Please note that if LAN connection is used then the network may cause additional delays. This could result that batch switching does not occur. Below example shows a command that resulted batch switching:

One by one commands	Batch commands
→ {02@01 V}	→ {02@01}{05@04}
← (001 I02)CrLf	← (001 I02)CrLf
→ {05@04 V}	← (004 I05)CrLf
← (004 I05)CrLf	

6.4. Network Configuration

6.4.1. Query the Current IP Status

Description: IP status can be queried as follows:

Format	Example
Command {IP_STAT=?}	→ {ip_stat=?}
Response (IP_STAT=<type>;<ip_address>;<subnet_mask>;<gateway_addr>)CrLf	← (IP_STAT=0;192.168.0.101;255.255.255.0;192.168.0.1)CrLf

Legend:

- <type>: 0 = static IP; 1 = DHCP.
- <ip_addr>: IP address (four decimal octets separated by dots).
- <subnet_mask>: Subnet mask (four decimal octets separated by dots).
- <gateway_addr>: Gateway address (four decimal octets separated by dots).

Explanation: The device has a static (fix) IP address: 192.168.0.101; the subnet mask is 255.255.255.0, the gateway address is 192.168.0.1.

6.4.2. Query the IP Address

Description: IP address can be queried as follows:

Format	Example
Command {IP_ADDRESS=?}	→ {ip_address=?}
Response (IP_ADDRESS=<type>;<ip_address>)CrLf	← (IP_ADDRESS=0;192.168.0.101)CrLf

Legend:

- <type>: 0 = static IP; 1 = DHCP
- <ip_addr>: IP address (four decimal octets separated by dots).

INFO: The response contains the fix IP address that is stored in the device even if DHCP is enabled; in this case, this IP address is not valid.

6.4.3. Set the IP Address

Description: IP address can be set as follows:

Format	Example
Command {IP_ADDRESS=<type>;<ip_address>}	→ {ip_address=0;192.168.0.110}
Response (IP_ADDRESS=<type>;<ip_address>)CrLf	← (IP_ADDRESS=0;192.168.0.110)CrLf

Legend: <type>: 0 = static IP; 1 = DHCP

6.4.4. Query the Subnet Mask

Description: Subnet mask can be queried as follows.

Format	Example
Command {IP_NETMASK=?}	→ {ip_netmask=?}
Response (IP_NETMASK=<subnet_mask>)CrLf	← (IP_NETMASK=255.255.255.0)CrLf

Legend: <subnet_mask>: Four decimal octets separated by dots.

INFO: The response contains the fix IP subnet mask value that is stored in the device even if DHCP is enabled; in this case, this IP subnet mask is not valid.

6.4.5. Set the Subnet Mask

Description: Subnet mask can be set as follows.

Format	Example
Command {IP_NETMASK=<subnet_mask>}	→ {ip_netmask=255.255.255.0}
Response (IP_NETMASK=<subnet_mask>)CrLf	← (IP_NETMASK=255.255.255.0)CrLf

Legend: <subnet_mask>: Four decimal octets separated by dots.

6.4.6. Query the Gateway Address

Description: Gateway address can be set as follows.

Format	Example
Command {IP_GATEWAY=?}	→ {ip_gateway=?}
Response (IP_GATEWAY=<gateway_addr>)CrLf	← (IP_GATEWAY=192.168.0.50)CrLf

Legend: <gateway_addr>: Four decimal octets separated by dots.

INFO: The response contains the static IP gateway address that is stored in the device even if DHCP is enabled. In that case, the latest valid gateway address (for static IP) is stored.

6.4.7. Set the Gateway Address

Description: Gateway address can be set as follows.

Format	Example
Command {IP_GATEWAY=<gateway_addr>}	→ {ip_gateway=192.168.0.50}
Response (IP_GATEWAY=<gateway_addr>)CrLf	← (IP_GATEWAY=192.168.0.50)CrLf

Legend: <gateway_addr>: Four decimal octets separated by dots.

6.4.8. Apply Network Settings

Description: All the previous settings are applied and the network interface will be restarted.

Format	Example
Command {IP_APPLY}	→ {ip_apply}
Response (IP_APPLY)CrLf	← (IP_APPLY)CrLf

6.5. GPIO Settings

INFO: These commands are available in MMX8x4-HT420M model.

6.5.1. Query GPIO State

Description: Current GPIO state can be queried.

Format	Example
Command {GPIO<port_nr>=?}	→ {GPIO1=?}
Response (GPIO<port_nr>=<direction>;<output_level>)CrLf	← (GPIO1=0;H)

Legend: <direction>: I=Input O=Output
<output_level>: H=High L=Low

Explanation: The direction of GPIO1 is output and the output level is high.

6.5.2. Set GPIO State

Description: GPIO state can be changed.

Format	Example
Command {GPIO<port_nr>=<direction>;<output_level>}	→ {GPIO1=I;H}
Response (GPIO<port_nr>=<direction>;<output_level>)CrLf	← (GPIO1=I)

Legend: <direction>: I=Input O=Output
<output_level>: H=High L=Low

Explanation: The direction of GPIO1 is input (and the input level is always high).

6.6. Relay Settings

INFO: These commands are available in MMX8x4-HT420M model.

6.6.1. Query Relay Connection State

Description: Current relay connection state can be queried.

Format	Example
Command {RELAY<port_nr>=?}	→ {RELAY1=?}
Response (RELAY<port_nr>=<dir>;<state>)CrLf	← (RELAY1=0;0)

Legend: <dir>: it is always 0.

<state>: 0=opened; C=closed

Explanation: Relay1 is opened now.

6.6.2. Set Relay Connection State

Description: Relay connection state can be changed to be opened or closed.

Format	Example
Command {RELAY<port_nr>=<dir>;<state>}	→ {RELAY1=0;C}
Response (RELAY<port_nr>=<dir>;<state>)CrLf	← (RELAY1=0;C)

Legend: <dir>: it is always 0.

<state>: 0=opened; C=closed

Explanation: Relay1 is opened now.

6.7. LW2 Commands – Quick Summary

General LW2 Commands

Operation	See in section	Command
View Product Type	6.2.1	{I}
View Serial Number	6.2.2	{S}
Query Device Label	6.2.3	{LABEL=?}
Query Control Protocol	6.2.4	{P_?}
View Firmware Version of the CPU	6.2.5	{F}
Connection Test	6.2.6	{PING}
Compile Time	6.2.7	{CT}
View Installed Board(s)	6.2.8	{IS}
View Firmware for all Controllers'	6.2.9	{FC}

Operation	See in section	Command
Restart the Matrix Router	6.2.10	{RST}
Query Health Status	6.2.11	{ST}
Restore Factory Default Settings	6.2.12	{FACTORY=ALL}

Port and Crosspoint Settings

Operation	See in section	Command
Switch One Input to One Output	6.3.1	{<in>@<out>}
Switch One Input to All Output	6.3.2	{<in>@0}
Mute Specified Output	6.3.3	{#<out>}
Unmute Specified Output	6.3.4	{+<out>}
Lock the Output	6.3.5	{#><out>}
Unlock the Output	6.3.6	{+<<out>}
View Connection State on the Output	6.3.7	{VC}
View Crosspoint Size	6.3.8	{getsize}
Batch Switch Outputs	6.3.9	{<in>@<out>}{<in>@<out>}

Network Configuration

Operation	See in section	Command
Query the Current IP Status	6.4.1	{IP_STAT=?}
Query the IP Address	6.4.2	{IP_ADDRESS=?}
Set the IP Address	6.4.3	{IP_ADDRESS=<type>;<ip_address>}
Query the Subnet Mask	6.4.4	{IP_NETMASK=?}
Set the Subnet Mask	6.4.5	{IP_NETMASK=<subnet_mask>}
Query the Gateway Address	6.4.6	{IP_GATEWAY=?}
Set the Gateway Address	6.4.7	{IP_GATEWAY=<gateway_addr>}
Apply Network Settings	6.4.8	{IP_APPLY}

GPIO Settings

Operation	See in section	Command
Query GPIO State	6.5.1	{GPIO<port_nr>=?}
Set GPIO State	6.5.2	{GPIO<port_nr>=<direction>;<output_level>}

Relay Settings

Operation	See in section	Command
Query Relay Connection State	6.6.1	{RELAY<port_nr>=?}
Set Relay Connection State	6.6.2	{RELAY<port_nr>=<dir>;<state>}

7

LW3 Programmers' Reference

The device can be controlled through Lightware 3 (LW3) protocol commands to ensure the compatibility with other Lightware products. The supported LW3 commands are described in this chapter.

- ▶ OVERVIEW
- ▶ PROTOCOL RULES
- ▶ SYSTEM COMMANDS
- ▶ SWITCHING AND CROSSPOINT SETTINGS
- ▶ VIDEO PORT SETTINGS
- ▶ EDID MANAGEMENT
- ▶ AUX ANALOG AUDIO I/O PORT SETTINGS
- ▶ ADVANCED AUDIO SETTINGS
- ▶ SERIAL PORT SETTINGS
- ▶ IR PORT SETTINGS
- ▶ RELAY PORT SETTINGS
- ▶ GPIO PORT SETTINGS
- ▶ NETWORK CONFIGURATION
- ▶ SENDING MESSAGE VIA THE COMMUNICATION PORTS
- ▶ SYSTEM MONITORING COMMANDS
- ▶ LW3 QUICK SUMMARY

7.1. Overview

The Lightware Protocol #3 (LW3) is implemented in almost all new Lightware devices (matrix switchers, signal extenders and distribution amplifiers) since 2012. The protocol is ASCII-based and all commands are terminated with a carriage return (Cr, '\r') and line feed (Lf, '\n') pair. It is organized as a tree structure that provides outstanding flexibility and user-friendly handling with 'nodes', 'properties' and 'methods'. The **Advanced View** of the Lightware Device Controller software is the perfect tool for browsing and learning how the LW3 protocol can be used in practice.

7.2. Protocol Rules

7.2.1. LW3 Tree Structure and Command Structure (examples)

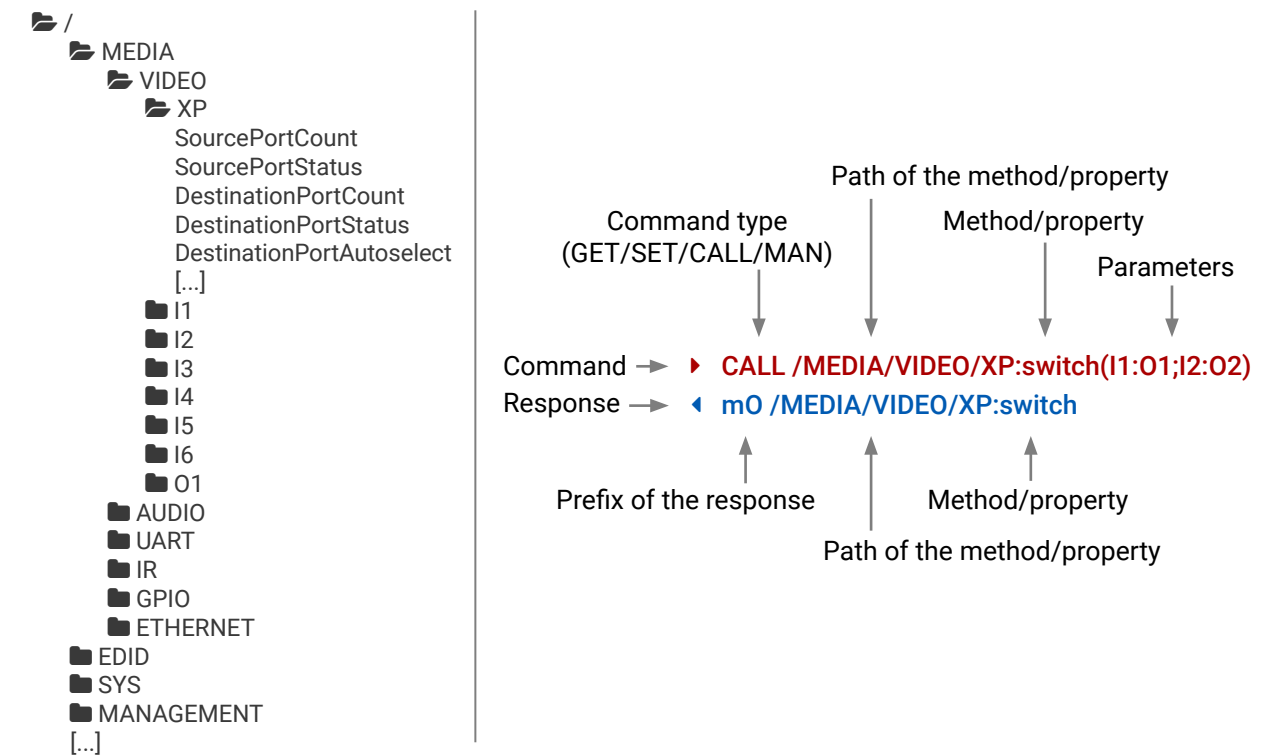

7.2.2. General Rules

- All names and parameters are **case-sensitive**.
- The nodes are separated by a slash (/) character.
- The node name can contain the elements of the English alphabet and numbers.
- Use the **TCP port no. 6107** when using LW3 protocol over Ethernet.
- When a command is issued by the device, the received response cannot be processed by the CPU.
- The node paths describe the exact location of the node, listing each parent node up to the root.

7.2.3. Command Types

GET command

The **GET** command can be used to get the child nodes, properties and methods of a specific node. It can also be used to get the value of a property. Use the dot character (.) when addressing a property:

- ▶ **GET /.SerialNumber**
- ◀ **pr /.SerialNumber=87654321**

GETALL command

The **GETALL** command can be used to get all child nodes, properties and methods of a node with one command.

- ▶ **GETALL /MEDIA/UART**
- ◀ **ns /MEDIA/UART/P1**
- ◀ **ns /MEDIA/UART/P2**
- ◀ **pr /MEDIA/UART.PortCount=2**
- ◀ **pr /MEDIA/UART.PortUi=P1:12209;P2:12224**
- ◀ **pr /MEDIA/UART.P1=Local RS-232**
- ◀ **pr /MEDIA/UART.P2=TPS out RS-232**

SET command

The **SET** command can be used to modify the value of a property. Use the dot character (.) when addressing the property:

- ▶ **SET /MEDIA/VIDEO/I1.ColorSpaceMode=0**
- ◀ **pw /MEDIA/VIDEO/I1.ColorSpaceMode=0**

CALL command

A method can be invoked by the **CALL** command. Use the colon character (:) when addressing the method:

- ▶ **CALL /MEDIA/VIDEO/XP:switch(I1:01)**
- ◀ **mO /MEDIA/VIDEO/XP:switch**

MAN command

The manual is a human readable text that describes the syntax and provides a hint for how to use the primitives. For every node, property and method in the tree there is a manual, type the MAN command to get the manual:

- ▶ **MAN /MEDIA/VIDEO/O1.Pwr5vMode**
- ◀ **pm /MEDIA/VIDEO/O1.Pwr5vMode ["0" | "1" | "2"] 0 - Auto, 1 - Always On, 2 - Always Off**

7.2.4. Prefix Summary

DEFINITION: The prefix is a 2-character long code that describes the type of the response.

The following prefixes are defined in the LW3 protocol:

Prefix	Description	Prefix	Description
n-	a node	pm	a manual for the property
nE	an error for a node	m-	a method
nm	a manual for a node	mO	a response after a success method execution
pr	a read-only property	mF	a response after a failed method execution
pw	read-write property	mE	an error for a method
pE	an error for the property	mm	a manual for a method

7.2.5. Error Messages

There are several error messages defined in the LW3 protocol, all of them have a unique error number.

- ▶ **CALL /MEDIA/VIDEO/XP:switch(IA:01)**
- ◀ **mE /MEDIA/VIDEO/XP:switch %E004:Invalid value**

7.2.6. Escaping

DEFINITION: An escape sequence is a sequence of characters that does not represent itself when used inside a character or string literal, but is translated into another character or a sequence of characters.

Property values and method parameters can contain characters which are used as control characters in the protocol. They must be escaped. The escape character is the backslash (\) and escaping means injecting a backslash before the character that should be escaped (like in C language).

Control characters are the following: \ { } # % () \r \n \t

The **original** message: **CALL /MEDIA/UART/P1:sendMessage(Set(01))**

The **escaped** message: **CALL /MEDIA/UART/P1:sendMessage(Set\01\))**

7.2.7. Signature

DEFINITION: The signature is a four-digit-long hexadecimal value that can be optionally placed before every command to keep a command and the corresponding responses together as a group.

Each line is terminated with a carriage return (Cr, '\r') and line feed (Lf, '\n') characters. In several cases the number of the lines in the response cannot be determined in advance, e.g. the client intends to receive for the whole response and also wants to be sure, that the received lines belong together and to the same command. In these cases, a special feature the 'signature' can be used. The response to that particular command will also be preceded by the signature, and the corresponding lines will be between brackets:

```
▶ 1700#GET /EDID.*
◀ {1700
◀ pr /EDID.EdidStatus=F89:E1;D1:E2;D1:E3;D1:E4;F89:E5
◀ m- /EDID:copy
◀ m- /EDID:delete
◀ m- /EDID:reset
◀ m- /EDID:switch
◀ m- /EDID:switchAll
◀ }
```

INFO: The lines of the signature are also Cr and Lf terminated.

7.2.8. Subscription

DEFINITION: Subscription to a node means that the user will get a notification if a property of the node changes.

A user can subscribe to any node. These notifications are asynchronous messages and are useful to keep the client application up to date, without having to periodically poll the node to detect a changed property. When the user does not want to be informed about the changes anymore, he can simply unsubscribe from the node.

ATTENTION! The subscriptions are handled separately for connections. Hence, if the connection is terminated all registered subscriptions are deleted. After reopening a connection all subscribe commands have to be sent in order to get the notifications of the changes on that connection.

Subscribe to a Node

```
▶ OPEN /MEDIA/VIDEO
◀ o- /MEDIA/VIDEO
```

Get the Active Subscriptions

```
▶ OPEN
◀ o- /MEDIA/VIDEO
◀ o- /EDID
◀ o- /DISCOVERY
```

Subscribe to Multiple Nodes

```
▶ OPEN /MEDIA/VIDEO/*
◀ o- /MEDIA/VIDEO/*
```

Unsubscribe from a Node

```
▶ CLOSE /MEDIA/VIDEO
◀ c- /MEDIA/VIDEO
```

Unsubscribe from Multiple Nodes

```
▶ CLOSE /MEDIA/VIDEO/*
◀ c- /MEDIA/VIDEO/*
```

7.2.9. Notifications about the Changes of the Properties

When the value of a property is changed and the user is subscribed to the node, which the property belongs to, an asynchronous notification is generated. This notification is called as the 'change message'. The format of such a message is very similar to the response for the **GET** command:

```
◀ CHG /EDID.EdidStatus=F48:E1
```

A Short Example of How to Use the Subscription

There are two independent users controlling the device through two independent connections (**Connection #1** and **Connection #2**). The events in the rows occur after each other.

```
▶ OPEN /MEDIA/VIDEO/QUALITY
◀ o- /MEDIA/VIDEO/QUALITY
▶ GET /MEDIA/VIDEO/Quality.QualityMode
◀ pm /MEDIA/VIDEO/QUALITY.QualityMode=graphic
▶ GET /MEDIA/VIDEO/Quality.QualityMode
◀ pm /MEDIA/VIDEO/QUALITY.QualityMode=graphic
▶ SET /MEDIA/VIDEO/Quality.QualityMode=video
◀ pw /MEDIA/VIDEO/QUALITY.QualityMode=video
◀ CHG /MEDIA/VIDEO/QUALITY.QualityMode=video
```

} Connection #1
} Connection #2
→ Connection #1

Explanation: The first user (**Connection #1**) set a subscription to a node. Later the other user (**Connection #2**) made a change, and thanks for the subscription, the first user got a notification about the change.

7.2.10. Legend for the Control Commands

Format	Description
<in>	Input port number
<out>	Output port number
<port>	Input or output port number
<loc>	Location number
<parameter>	Variable, which is defined and described in the command
<expression>	Batched parameters: the underline means that more expressions or parameters can be placed by using a semicolon, e.g. <u>I2;I4;I5</u> or <u>F27:E1;F47:E2</u>
▶	Sent command
◀	Received response
•	Space character

7.3. System Commands

7.3.1. Query the Product Name

The name of the product is a read-only parameter and cannot be modified.

Command and Response

- ▶ GET•/.ProductName
- ◀ pr•/.ProductName=<product_name>

Example

- ▶ GET /.ProductName
- ◀ pr /.ProductName=MMX8x4-HT420M

7.3.2. Query the Device Label

Command and Response

- ▶ SET•/MANAGEMENT/UID/DeviceLabel=<custom_name>
- ◀ pw•/MANAGEMENT/UID/DeviceLabel=<custom_name>

Parameters

<custom_name> The Device Label can be 39 character long and ASCII characters are allowed. Longer names will be truncated.

Example

- ▶ SET /MANAGEMENT/UID.DeviceLabel=MMX_Control_room
- ◀ pw /MANAGEMENT/UID.DeviceLabel=MMX_Control_room

7.3.3. Set the Device Label

ATTENTION! The device label can be changed to a custom text which is displayed in many windows of the LDC. This writable parameter is not the same as the ProductName parameter.

Command and Response

- ▶ SET•/MANAGEMENT/UID/DeviceLabel=<custom_name>
- ◀ pw•/MANAGEMENT/UID/DeviceLabel=<custom_name>

Parameters

<custom_name> The Device Label can be 39 character long and ASCII characters are allowed. Longer names will be truncated.

Example

- ▶ SET /MANAGEMENT/UID.DeviceLabel=MMX_Control_room
- ◀ pw /MANAGEMENT/UID.DeviceLabel=MMX_Control_room

7.3.4. Query the Serial Number

Command and Response

- ▶ GET•/.SerialNumber
- ◀ pr•/.SerialNumber=<serial_nr>

Example

- ▶ GET /.SerialNumber
- ◀ pr /.SerialNumber=00005484

7.3.5. Setting the Rotary Direction of the Jog Dial Knob

Command and Response

- ▶ SET•/MANAGEMENT/UI.RotaryDirection=<direction>
- ◀ pw•/MANAGEMENT/UI.RotaryDirection=<direction>

Parameters

- <direction> 0: The rotary direction of down is clockwise.
- 1: The rotary direction of down is counter clockwise.

Example

- ▶ SET /MANAGEMENT/UI.RotaryDirection=0
- ◀ pw /MANAGEMENT/UI.RotaryDirection=0

7.3.6. Control Lock

Enable/disable the operation of the jog dial control knob.

Command and Response

- ▶ SET•/MANAGEMENT/UI.ControlLock=<control_state>
- ◀ pw•/MANAGEMENT/UI.ControlLock=<control_state>

Parameters

- <control_state> 0: Unlocked - The jog dial knob (and the buttons) are unlocked.
- 1: Locked - The jog dial knob (and the buttons) are locked. In MMX8x8-HDMI-4K-A model, locked status can be changed with LW3 protocol command or by pressing Control Lock button for three seconds.
- 2: Force locked - The jog dial knob (and the buttons) are locked. This status can be changed only with LW3 protocol command.

Example

- ▶ SET /MANAGEMENT/UI.ControlLock=1
- ◀ pw /MANAGEMENT/UI.ControlLock=1

7.3.7. Identify the Device

Calling the method results **Device identified!** message on the LCD screen. The feature helps to identify the device itself in the rack shelf.

Command and Response

- ▶ CALL•/MANAGEMENT/UI:identifyMe()
- ◀ mO•/MANAGEMENT/UI:identifyMe

Example

- ▶ CALL /MANAGEMENT/UI:identifyMe()
- ◀ mO /MANAGEMENT/UI:identifyMe

7.3.8. Resetting the Matrix

The matrix can be restarted – the current connections (LAN, RS-232) will be terminated.

Command and Response

- ▶ CALL•/SYS:reset()
- ◀ mO•/SYS:reset=

Example

- ▶ CALL /SYS:reset()
- ◀ mO /SYS:reset=

7.3.9. Restore the Factory Default Settings

Command and Response

- ▶ CALL•/SYS:factoryDefaults()
- ◀ mO•/SYS:factoryDefaults=

Example

- ▶ CALL /SYS:factoryDefaults()
- ◀ mO /SYS:factoryDefaults=

The device is restarted, current connections are terminated, and the default settings are restored.

See the complete list in [Factory Default Settings](#) section.

7.4. Switching and Crosspoint Settings

7.4.1. Query the Video Crosspoint State

Command and Response

- ▶ GET•/MEDIA/VIDEO/XP.DestinationConnectionList
- ◀ pr•/MEDIA/VIDEO/XP.DestinationConnectionList=<out1_state>;<out2_state>;<...>;<o5_state>

Example

- ▶ GET /MEDIA/VIDEO/XP.DestinationConnectionList
- ◀ pr /MEDIA/VIDEO/XP.DestinationConnectionList=I1;I1;I8;I8;I1

I1 port is connected to O1,O2 and O5, I8 is connected to O3 and O4.

INFO: The response depends on the number of the output ports. MMX8x4-HT400MC and MMX8x4-HT420M models have 4 output ports, MMX8x8-HDMI-4K-A model has 8 output ports.

7.4.2. Switching an Input to an Output

Command and Response

- ▶ CALL•/MEDIA/VIDEO/XP:switch(<in>:<out>)
- ◀ mO•/MEDIA/VIDEO/XP:switch

Example

- ▶ CALL /MEDIA/VIDEO/XP:switch(I4:O1)
- ◀ mO /MEDIA/VIDEO/XP:switch

I4 port is connected to O1 port.

7.4.3. Switching an Input to All Outputs

Command and Response

- ▶ CALL•/MEDIA/VIDEO/XP:switchAll(<in>)
- ◀ mO•/MEDIA/VIDEO/XP:switchAll

Example

- ▶ CALL /MEDIA/VIDEO/XP:switchAll(I1)
- ◀ mO /MEDIA/VIDEO/XP:switchAll

TIPS AND TRICKS: All output ports can be disconnected by the '0' value:
CALL /MEDIA/VIDEO/XP:switchAll(0).

7.5. Video Port Settings

7.5.1. Mute an Input Port

Command and Response

- ▶ CALL•/MEDIA/VIDEO/XP:muteSource(<in>)
- ◀ mO•/MEDIA/VIDEO/XP:muteSource

Example

- ▶ CALL /MEDIA/VIDEO/XP:muteSource(I2)
- ◀ mO /MEDIA/VIDEO/XP:muteSource

7.5.2. Unmute an Input Port

Command and Response

- ▶ CALL•/MEDIA/VIDEO/XP:unmuteSource(<in>)
- ◀ mO•/MEDIA/VIDEO/XP:unmuteSource

Example

- ▶ CALL /MEDIA/VIDEO/XP:unmuteSource(I2)
- ◀ mO /MEDIA/VIDEO/XP:unmuteSource

7.5.3. Mute an Output Port

Command and Response

- ▶ CALL•/MEDIA/VIDEO/XP:muteDestination(<out>)
- ◀ mO•/MEDIA/VIDEO/XP:muteDestination

Example

- ▶ CALL /MEDIA/VIDEO/XP:muteDestination(O1)
- ◀ mO /MEDIA/VIDEO/XP:muteDestination

7.5.4. Unmute an Output Port

Command and Response

- ▶ CALL•/MEDIA/VIDEO/XP:unmuteDestination(<out>)
- ◀ mO•/MEDIA/VIDEO/XP:unmuteDestination

Example

- ▶ CALL /MEDIA/VIDEO/XP:unmuteDestination(O1)
- ◀ mO /MEDIA/VIDEO/XP:unmuteDestination

7.5.5. Lock an Input Port

Command and Response

- ▶ CALL•/MEDIA/VIDEO/XP:lockSource(<in>)
- ◀ mO•/MEDIA/VIDEO/XP:lockSource

Example

- ▶ CALL /MEDIA/VIDEO/XP:lockSource(I1)
- ◀ mO /MEDIA/VIDEO/XP:lockSource

7.5.6. Unlock an Input Port

Command and Response

- ▶ CALL•/MEDIA/VIDEO/XP:unlockSource(<in>)
- ◀ mO•/MEDIA/VIDEO/XP:unlockSource

Example

- ▶ CALL /MEDIA/VIDEO/XP:unlockSource(I1)
- ◀ mO /MEDIA/VIDEO/XP:unlockSource

7.5.7. Lock an Output Port

Command and Response

- ▶ CALL•/MEDIA/VIDEO/XP:lockDestination(<out>)
- ◀ mO•/MEDIA/VIDEO/XP:lockDestination

Example

- ▶ CALL /MEDIA/VIDEO/XP:lockDestination(O1)
- ◀ mO /MEDIA/VIDEO/XP:lockDestination

7.5.8. Unlock an Output Port

Command and Response

- ▶ CALL•/MEDIA/VIDEO/XP:unlockDestination(<out>)
- ◀ mO•/MEDIA/VIDEO/XP:unlockDestination

Example

- ▶ CALL /MEDIA/VIDEO/XP:unlockDestination(O1)
- ◀ mO /MEDIA/VIDEO/XP:unlockDestination

7.5.9. HDCP Setting (Input Port)

HDCP capability can be enabled/disabled on the input ports, thus, non-encrypted content can be seen on a non-HDCP compliant display. See more information in [HDCP Management](#) section.

Command and Response

- ▶ SET•/MEDIA/VIDEO/<In>.HdcpEnable=<hdcp_status>
- ◀ pw•/MEDIA/VIDEO/<In>.HdcpEnable=<hdcp_status>

Parameters

<hdcp_status> **true:** HDCP enabled
false: HDCP disabled

Example

- ▶ SET /MEDIA/VIDEO/I1.HdcpEnable=false
- ◀ pw /MEDIA/VIDEO/I1.HdcpEnable=false

7.5.10. HDCP Setting (Output Port)

HDCP capability can be set to Auto/Always on the output ports, thus, non-encrypted content can be transmitted to a non-HDCP compliant display. See more information in [HDCP Management](#) section.

Command and Response

- ▶ SET•/MEDIA/VIDEO/<On>.HdcpModeSetting=<hdcp_mode>
- ◀ pw•/MEDIA/VIDEO/<On>.HdcpModeSetting=<hdcp_mode>

Parameters

<hdcp_mode> **0:** Auto
1: Always

Example

- ▶ SET /MEDIA/VIDEO/O1.HdcpModeSetting=0
- ◀ pw /MEDIA/VIDEO/O1.HdcpModeSetting=0

7.5.11. Query the Status of Source Port

Command and Response

- ▶ GET•/MEDIA/VIDEO/XP.SourcePortStatus
- ◀ pr•/MEDIA/VIDEO/XP.SourcePortStatus=<in1_state>;<in2_state>;<...>;<in#_state>

Parameters

<in#_state> the The responses contain one letter and a 1-byte long HEX code showing the current state of the input ports. See the legend below.

Example

- ▶ GET /MEDIA/VIDEO/XP.SourcePortStatus
- ◀ pr /MEDIA/VIDEO/XP.SourcePortStatus=M00AA;L00AA;T00AA;T00AA;T00AA;T00AA;T00EF;T00AA

Legend

Letter (Character 1)		
	Mute state	Lock state
T	Unmuted	Unlocked
L	Unmuted	Locked
M	Muted	Unlocked
U	Muted	Locked

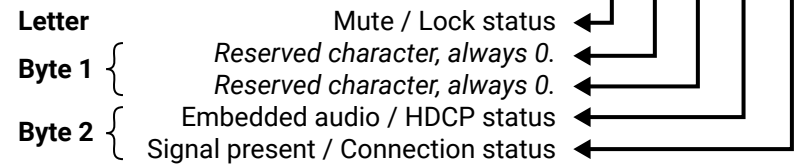

	Byte 1				Byte 2			
	Character 2		Character 3		Character 4		Character 5	
	BIT 7-6	BIT 5-4	BIT 3-2	BIT 1-0	BIT 7-6	BIT 5-4	BIT 3-2	BIT 1-0
	Reserved	Reserved	Reserved	Reserved	Embedded audio status	HDCP status	Signal present status	Connection status
00	Reserved	Reserved	Reserved	Reserved	Unknown			
01					Reserved			
10					No embedded audio	Not encrypted	No signal	Not connected
11					Embedded audio presents	Encrypted	Signal presents	Connected

Example and Explanation (M00AA):

T	0		0		A		A	
Unlocked, Unmuted	00	00	00	00	10	10	10	10
	Reserved	Reserved	Reserved	Reserved	No embedded audio	Not encrypted	No signal	Not connected

The Most Common Received Port Status Responses

T00AA	T	0		0		A		A	
Unlocked, Unmuted	00	00	00	00	10	10	10	10	
	Reserved	Reserved	Reserved	Reserved	No embedded audio	Not encrypted	No signal	Not connected	

T00AB	T	0		0		A		B	
Unlocked, Unmuted	00	00	00	00	10	10	10	11	
	Reserved	Reserved	Reserved	Reserved	No embedded audio	Not encrypted	No signal	Connected	

T00AF	T	0		0		A		F	
Unlocked, Unmuted	00	00	00	00	10	10	11	11	
	Reserved	Reserved	Reserved	Reserved	No embedded audio	Not encrypted	Signal presents	Connected	

T00EF	T	0		0		E		F	
Unlocked, Unmuted	00	00	00	00	11	10	11	11	
	Reserved	Reserved	Reserved	Reserved	Embedded audio presents	Not encrypted	Signal presents	Connected	

T00BF	T	0		0		B		F	
Unlocked, Unmuted	00	00	00	00	10	11	11	11	
	Reserved	Reserved	Reserved	Reserved	No embedded audio	Encrypted	Signal presents	Connected	

T00FF	T	0		0		F		F	
Unlocked, Unmuted	00	00	00	00	11	11	11	11	
	Reserved	Reserved	Reserved	Reserved	Embedded audio presents	Encrypted	Signal presents	Connected	

7.5.12. Query the Status of Destination Port

Command and Response

- ▶ GET•/MEDIA/XP/VIDEO.DestinationPortStatus
- ◀ pr•/MEDIA/XP/VIDEO.DestinationPortStatus=<out1_state>;<out2_state>;<...>;<out#_state>

Parameters

<out#_state> The responses contain one letter and a 1-byte long HEX code showing the current state of the output ports. See the Legend in [Query the Status of Source Port](#) section.

INFO: The response depends on the number of the output ports. MMX8x4-HT400MC and MMX8x4-HT420M models have 4 output ports, MMX8x8-HDMI-4K-A model has 8 output ports.

Example

- ▶ GET /MEDIA/VIDEO/XP.DestinationPortStatus
 - ◀ pr /MEDIA/VIDEO/XP.DestinationPortStatus=L00AA;T00AE;T00AF;T00AA;T00AB
- INFO: Output 5 in MMX8x4-HT400MC and MMX8x4-HT420M models means the advanced analog audio output.

7.5.13. Query the Video Autoselect Settings

Command and Response

- ▶ GET•/MEDIA/VIDEO/XP.DestinationPortAutoselect
- ◀ pr•/MEDIA/VIDEO/XP.DestinationPortAutoselect=<out1_set>;<out2_set>;<...>;<out#_set>

The response shows the settings of each output one by one.

Parameters

Identifier	Parameter description		Parameter values
<out#_set>	Two-letter code of the Autoselect settings	1 st letter	E: Autoselect is enabled D: Autoselect is disabled
		2 nd letter	F: First detect mode: the first active video input is selected. P: Priority detect: always the highest priority active video input will be selected. L: Last detect: always the last attached input is switched to the output automatically.

Example

- ▶ GET /MEDIA/VIDEO/XP.DestinationPortAutoselect
- ◀ pr /MEDIA/VIDEO/XP.DestinationPortAutoselect=DP;EP;EF;DP;DP

DP: the autoselect is Disabled on output 1, output 4, and output 5.

EP: the Autoselect is Enabled on output 2 (selected mode is Priority detect).

EF: the Autoselect is Enabled on output 3 (selected mode is First detect).

INFO: For more information see [The Autoselect Feature](#) section.

INFO: Output 5 in MMX8x4-HT400MC and MMX8x4-HT420M models means the advanced analog audio output.

7.5.14. Change the Autoselect Mode

Command and Response

- ▶ CALL•/MEDIA/VIDEO/XP:setDestinationPortAutoselect(<out>:<out_set>)
- ◀ mO•/MEDIA/VIDEO/XP:setDestinationPortAutoselect

Parameters

See the previous section.

Example

- ▶ CALL /MEDIA/VIDEO/XP:setDestinationPortAutoselect(O1:EF)
- ◀ mO /MEDIA/VIDEO/XP:setDestinationPortAutoselect

The Autoselect mode is Enabled on Output 1 in First detect mode.

INFO: Output 5 in MMX8x4-HT400MC and MMX8x4-HT420M models means the advanced analog audio output.

7.5.15. Query the Input Port Priority

Command and Response

- ▶ GET•/MEDIA/VIDEO/XP.PortPriorityList
- ◀ pr•/MEDIA/VIDEO/XP.PortPriorityList=<out1_list>;<out2_list>;<...>;<out#_list>

The response shows the priority of each output one after another. The priority number can be from 0 to 31; 0 is the highest- and 30 is the lowest priority. 31 means that the port will be skipped from the priority list.

Parameters

<out_list> The input port priority order of the given output port: <in1>;<in2>;<...>;<in>

Example

- ▶ GET /MEDIA/VIDEO/XP.PortPriorityList
- ◀ /MEDIA/VIDEO/XP.PortPriorityList=7,6,5,4,3,2,1,0;0,1,2,3,4,5,6,7;0,1,2,3,4,5,6,7;0,1,2,3,4,5,6,7;0,1,2,3,4,5,6,7

There are five outputs, so there are five groups listed in the response (divided by semicolons) and each group (list) contains eight priority numbers.

The response: 7,6,5,4,3,2,1,0;0,1,2,3,4,5,6,7;0,1,2,3,4,5,6,7;0,1,2,3,4,5,6,7;0,1,2,3,4,5,6,7.

Those values show the priority order of the video input ports:

Output 1								Output 2								Output 3							
I1	I2	I3	I4	I5	I6	I7	I8	I1	I2	I3	I4	I5	I6	I7	I8	I1	I2	I3	I4	I5	I6	I7	I8
7	6	5	4	3	2	1	0	0	1	2	3	4	5	6	7	0	1	2	3	4	5	6	7

Output 3								Output 5							
I1	I2	I3	I4	I5	I6	I7	I8	I1	I2	I3	I4	I5	I6	I7	I8
0	1	2	3	4	5	6	7	0	1	2	3	4	5	6	7

In the above example, the Input 8 has the highest priority and Input 7 has the lowest priority on O1. On O2 O3, O4 and O5 ports the setting is the opposite.

ATTENTION! The same priority number can be set to different input ports. When the priority numbers match, the input port with the lowest port number will have the highest priority.

INFO: Output 5 in MMX8x4-HT400MC and MMX8x4-HT420M models means the advanced analog audio output.

7.5.16. Changing the Input Port Priority

This method **required** escaping the control characters. For more information see the [Escaping](#) section. One or more input can be set in the same time.

Command and Response

- ▶ CALL•/MEDIA/VIDEO/XP:setAutoselectionPriority(<in>\(<out>\):<prio>);(<in>\(<out>\):<prio>)
- ◀ mO•/MEDIA/VIDEO/XP:setAutoselectionPriority

Parameters

<prio> Priority number from 0 to 31, equal numbers are allowed (31 means that the port will be skipped from the priority list).

An input port priority can be set on an output port. Many settings can be executed by separating a semicolon (no space), see the example below.

Example

- ▶ CALL /MEDIA/VIDEO/XP:setAutoselectionPriority(I1(O1):31;I2(O1):1;I3(O1):2;I4(O1):3;5(O1):4;I6(O1):5;I7(O1):6;I8(O1):7)
- ◀ mO /MEDIA/VIDEO/XP:setAutoselectionPriority

The Input 1 is ignored from the autoselection, priority order of the inputs are: I2, I3, I4, I5, I6, I7, I8.

7.5.17. TPS Mode Settings on TPS Ports

INFO: This command is available in MMX8x4-HT400MC and MMX8x4-HT420M models.

Command and Response

- ▶ SET•/REMOTE/<tps_port>.tpsModeSetting=<tps_mode_setting>
- ◀ pw•/REMOTE/<tps_port>.tpsModeSetting=<tps_mode_setting>

Example

- ▶ SET /REMOTE/S2.tpsModeSetting=A
- ◀ pw /REMOTE/S2.tpsModeSetting=A

Parameters

Identifier	Parameter description	Parameter values
<tps_port>	TPS input or output port	S1-S4 for inputs D1-D2* for outputs
<tps_mode_setting>	TPS mode	A: Auto H: HDBaseT L**: Longreach 1: LPPF1 2**: LPPF2

* TPS output ports are not available in MMX8x4-HT400MC model.

** Long reach and LPPF2 mode is not available in MMX8x4-HT400MC model.

For more information see [TPS Working Modes](#) section.

7.5.18. Sending CEC Commands

INFO: The hidden first 2 bit of the CEC command is static (always 04), it refers to the logical address of the sender and the addressee. **0**: sender is a **TV**; **4**: the addressee is the **Playback Device 1**.

7.5.18.1. Sending OSD String

Sending the OSD string consists of two steps. First, set the CEC.OsdString property with the desired text, after that, call the CEC.send(set_osd) method.

Step 1. Set the **CEC.OsdString** property.

- ▶ SET /MEDIA/CEC/<port>.OsdString=<text>
- ◀ pw /MEDIA/CEC/<port>.OsdString=<text>

Step 2. Call the **CEC.send(set_osd)** method.

- ▶ CALL /MEDIA/CEC/<port>:send(set_osd)
- ◀ mO /MEDIA/CEC/<port>:send

Parameters

Identifier	Parameter description	Parameter values
<port>	Port identifier	I1-I8 : Source port number. O1-O5 : Destination port number in MMX8x4-HT-400MC and MMX8x4-HT-420M models. O1-O8 : Destination port number in MMX8x8-HDMI-4K-A.
<text>	On-screen displayed text	The following characters are allowed in the text: Letters (A-Z) and (a-z), hyphen (-), underscore (_), numbers (0-9), and dot (.). Max length: 14 characters.

Example

- ▶ SET /MEDIA/CEC/I1.OsdString=Lightware
- ◀ pw /MEDIA/CEC/I1.OsdString=Lightware
- ▶ CALL /MEDIA/CEC/I1:send(set_osd)
- ◀ mO /MEDIA/CEC/I1:send

7.5.18.2. Send CEC Command in Text Format

- ▶ CALL /MEDIA/CEC/<port>:send(<command>)
- ◀ mO /MEDIA/CEC/<port>:send

Parameters

Identifier	Parameter description	Parameter values
<port>	Port identifier	I1-I8 : Source port number. O1-O5 : Destination port number in MMX8x4-HT-400MC and MMX8x4-HT-420M models. O1-O8 : Destination port number in MMX8x8-HDMI-4K-A.
<command>	CEC command	image_view_on / standby ok / back up / down / left / right root_menu / setup_menu / contents_menu / favorite_menu/ media_top_menu / media_context_menu number_0 / number_1 / number_2 / number_3 / number_4 / number_5 / number_6 / number_7 / number_8 / number_9 / dot / enter / clear channel_up / channel_down sound_select / input_select display_info / power_legacy page_up / page_down volume_up / volume_down mute_toggle / mute / unmute play/ stop/ pause / record / rewind / fast_forward / eject/ skip_forward/ skip_backward 3d_mode stop_record / pause_record play_forward / play_reverse select_next_media / select_media_1/ select_media_2 / select_media_3 /select_media_4 / select_media_5 power_toggle / power_on / power_off f1 / f2 / f3 / f4 / stop_function

Example

- ▶ CALL /MEDIA/CEC/I5:send(play)
- ◀ mO /MEDIA/CEC/I5:send

7.5.18.3. Send CEC Command in Hexadecimal Format

- ▶ CALL /MEDIA/CEC/<port>:sendHex(<hex_code>)
- ◀ mO /MEDIA/CEC/<port>:sendHex

Parameters

<hex_code> Accepted command is max. 30 character long (15 byte) in hexadecimal format.

Example

- ▶ CALL /MEDIA/CEC/I5:sendHex(8700E091)
- ◀ mO /MEDIA/CEC/I5:sendHex

7.5.19. PoE Enable

INFO: This command is available in MMX8x4-HT420M model.

Command and Response

- ▶ SET•/REMOTE/<tps_port>.PoeEnabled=<poe_status>
- ◀ pw•/REMOTE/<tps_port>.PoeEnabled=<poe_status>

Parameters

Identifier	Parameter description	Parameter values
<tps_port>	TPS port number	S1-S4 for inputs D1-D2* for outputs
<poe_status>	PoE status	true: PoE enabled false: PoE disabled

* TPS output ports are not available in MMX8x4-HT400MC model.

Example

- ▶ SET /REMOTE/S2.PoeEnabled=true
- ◀ pw /REMOTE/S2.PoeEnabled=true

7.5.20. Signal Type Settings (Output Ports)

Command and Response

- ▶ SET•/MEDIA/VIDEO/<out>.HdmiModeSetting=<signal_type>
- ◀ pw•/MEDIA/VIDEO/<out>.HdmiModeSetting=<signal_type>

Example

- ▶ SET /MEDIA/VIDEO/O1.HdcpModeSetting=1
- ◀ pw /MEDIA/VIDEO/O1.HdcpModeSetting=1

Parameters

<signal_type> Signal type **0:** Auto; **1:** DVI; **2:** HDMI

7.5.21. Test Pattern

The output ports can send a special image towards the sink devices for testing purposes. The setting is available on output ports with the below-listed parameters.

ATTENTION! The Mode can be set individually on each port, but the Clock source and the Pattern settings are common on the O1 and O2, O3 and O4 output ports.

7.5.21.1. Test pattern generator mode setting

Command and Response

- ▶ SET•/MEDIA/VIDEO/<out>.TpgMode=<tpg_mode>
- ◀ pw•/MEDIA/VIDEO/<out>.TpgMode=<tpg_mode>

Parameters

Identifier	Parameter description	Parameter values
<tpg_mode>	Test pattern generator mode	0: Disabled - The test pattern is not displayed on the output. 1: Enabled - The test pattern is displayed on the output. 2: No signal mode - The test pattern is displayed if there is no signal on the output port.

Example

- ▶ SET /MEDIA/VIDEO/O1.TpgMode=1
- ◀ pw /MEDIA/VIDEO/O1.TpgMode=1

7.5.21.2. Clock source – the clock frequency of the test pattern

Command and Response

- ▶ SET•/MEDIA/VIDEO/<out>.TpgClockSource=<tpg_clocksource>
- ◀ pw•/MEDIA/VIDEO/<out>.TpgClockSource=<tpg_clocksource>

Parameters

Identifier	Parameter description	Parameter values
<tpg_clocksource>	Clock frequency	480: 480p 576: 576p EXT: External clock (from current TMDS source)

Example

- ▶ SET /MEDIA/VIDEO/O1.TpgClockSource=576
- ◀ pw /MEDIA/VIDEO/O1.TpgClockSource=576

7.5.21.3. Test pattern

Command and Response

- ▶ SET•/MEDIA/VIDEO/<out>.TpgPattern=<pattern>
- ◀ pw•/MEDIA/VIDEO/<out>.TpgPattern=<pattern>

Parameters

<pattern> RED GREEN BLUE BLACK WHITE RAMP CHESS BAR CYCLE

Cycle setting means all the patterns are changed sequentially approx. in every 2 seconds.

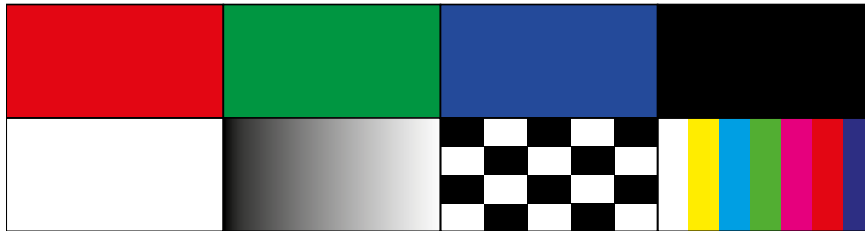

Example

- ▶ SET /MEDIA/VIDEO/O3.TpgPattern=BLUE
- ◀ pw /MEDIA/VIDEO/O3.TpgPattern=BLUE

7.6. EDID Management

7.6.1. Query the Emulated EDIDs

It displays the emulated EDID memory place for each input port (I1-I8).

Command and Response

- ▶ GET•/EDID.EdidStatus
- ◀ pr•/EDID.EdidStatus=<source>:E1;<source>:E2;<...>;<source>:E8

Parameters

Identifier	Parameter description	Parameter values
<source>	Source EDID memory place	F#: Factory (F1-149) U#: User (U1- U24* or U1- U27) D#: Dynamic (D1-D5 or D1-D8*)

* In MMX8x8-HDMI-4K-A model.

Example

- ▶ GET /EDID.EdidStatus
- ◀ pr /EDID.EdidStatus=F149:E1;F47:E2;F47:E3;F47:E4;F47:E5;F47:E6;F47:E7;F47:E8

All emulated EDID memories (inputs) are listed with the EDID number that is currently emulated on the input separated by semicolons. Above example shows that F149 EDID (149th Factory EDID) is emulated on I1 (E1) port, and F47 is emulated on all other input ports.

7.6.2. Set the Emulated EDID

Command and Response

- ▶ CALL•/EDID:switch(<source>:<destination>)
- ◀ mO•/EDID:switch

Parameters

Identifier	Parameter description	Parameter values
<source>	Source EDID memory place	F#: Factory (F1-149) U#: User (U1- U24* or U1- U27) D#: Dynamic (D1-D5 or D1-D8*)
<destination>	The emulated EDID memory of the desired input port.	E#: Emulated (E1-E8)

* In MMX8x8-HDMI-4K-A model.

Example

- ▶ CALL /EDID:switch(F149:E2)
- ◀ mO /EDID:switch

7.6.3. Copy an EDID into Another Slot

ATTENTION! The (User) EDID memory slot will be overwritten without notification even if it was not empty.

Command and Response

- ▶ CALL•/EDID:copy(<source>:<destination>)
- ◀ mO•/EDID:copy

Parameters

Identifier	Parameter description	Parameter values
<source>	Source EDID memory place	F#: Factory (F1-149) U#: User (U1- U24* or U1- U27) D#: Dynamic (D1-D5 or D1-D8*)
<destination>	The desired User EDID memory slot	U#: User (U1- U24* or U1- U27)

* In MMX8x8-HDMI-4K-A model.

Many copy operations can be performed at the same time by using semicolons (see **Example2**).

Example1:

- ▶ CALL /EDID:copy(D2:U2)
- ◀ mO /EDID:copy

Example2:

- ▶ CALL /EDID:copy(D2:U5;D3:U6)
- ◀ mO /EDID:copy

7.7. AUX Analog Audio I/O Port Settings

INFO: Analog audio input/output setting commands are available in MMX8x4-HT420M model (I5 and I6 audio ports) and MMX8x8-HDMI-4K-A model (I2, I4, I6 and I8 audio ports).

7.7.1. Audio Mode Setting

Command and Response

- ▶ SET•/MEDIA/AUDIO/<in>.AudioMode=<audio_mode>
- ◀ pw•/MEDIA/AUDIO/<in>.AudioMode=<audio_mode>

Parameters

Identifier	Parameter description	Parameter values
<audio_mode>	Audio mode	0: HDMI audio passthrough 1: Embed from aux audio 2: De-embed to aux audio

Example

- ▶ SET /MEDIA/AUDIO/I6.AudioMode=1
- ◀ pw /MEDIA/AUDIO/I6.AudioMode=1

See more details see [Port diagram of the AUX analog audio I/O](#) in [Audio Interface](#) section.

7.7.2. AUX Analog Audio Input Settings

7.7.2.1. Mute

Command and Response

- ▶ SET•/MEDIA/AUDIO/<in>/ADCVOLUME.Mute=<mute_status>
- ◀ pw•/MEDIA/AUDIO/<in>/ADCVOLUME.Mute=<mute_status>

Parameters

<mute_status> **true:** muted;
 false: unmuted

Example

- ▶ SET /MEDIA/AUDIO/I6/ADCVOLUME.Mute=true
- ◀ pw /MEDIA/AUDIO/I6/ADCVOLUME.Mute=true

7.7.2.2. Volume

This command sets the volume in dB scale.

Command and Response

- ▶ SET•/MEDIA/AUDIO/<in>/ADCVOLUME.VoluedB=<volume_dB>
- ◀ pw•/MEDIA/AUDIO/<in>/ADCVOLUME.VoluedB=<volume_dB>

Parameters

<volume_dB> Volume can be set between -48.18dB and 0.00dB.

Example

- ▶ SET /MEDIA/AUDIO/I6/ADCVOLUME.VoluedB=-1
- ◀ pw /MEDIA/AUDIO/I6/ADCVOLUME.VoluedB=-1

7.7.2.3. Balance

Command and Response

- ▶ SET•/MEDIA/AUDIO/<in>/ADCVOLUME.Balance=<balance_value>
- ◀ pw•/MEDIA/AUDIO/<in>/ADCVOLUME.Balance=<balance_value>

Parameters

<balance_value> The balance value can be set between -100 (left) and +100 (right). Zero balance means the center setting.

Example

- ▶ SET /MEDIA/AUDIO/I6/ADCVOLUME.Balance=100
- ◀ pw /MEDIA/AUDIO/I6/ADCVOLUME.Balance=100

7.7.2.4. Gain

This command sets the input gain in dB scale.

Parameters

<gain_dB> The gain can be set between 0.00dB and 24.00dB.

Command and Response

- ▶ SET•/MEDIA/AUDIO/<in>/ADCVOLUME.Gain=<gain_dB>
- ◀ pw•/MEDIA/AUDIO/<in>/ADCVOLUME.Gain=<gain_dB>

Example

- ▶ SET /MEDIA/AUDIO/I6/ADCVOLUME.Gain=1.00
- ◀ pw /MEDIA/AUDIO/I6/ADCVOLUME.Gain=1.00

7.7.3. AUX Analog Audio Output Settings

7.7.3.1. Mute

Command and Response

- ▶ SET•/MEDIA/AUDIO/<in>.DACVOLUME.Mute=<mute_status>
- ◀ pw•/MEDIA/AUDIO/<in>.DACVOLUME.Mute=<mute_status>

Parameters

<mute_status> **true:** muted;
 false: unmuted

Example

- ▶ SET /MEDIA/AUDIO/I6/DACVOLUME.Mute=true
- ◀ pw /MEDIA/AUDIO/I6/DACVOLUME.Mute=true

7.7.3.2. Volume

This command sets the volume in dB scale.

Command and Response

- ▶ SET•/MEDIA/AUDIO/<in>/DACVOLUME.VoluedB=<volume_dB>
- ◀ pw•/MEDIA/AUDIO/<in>/DACVOLUME.VoluedB=<volume_dB>

Example

- ▶ SET /MEDIA/AUDIO/I6/DACVOLUME.VoluedB=-1
- ◀ pw /MEDIA/AUDIO/I6/DACVOLUME.VoluedB=-1

Parameters

<volume_dB> Volume can be set between -95.62dB and 0.00dB.

7.7.3.3. Balance

Command and Response

- ▶ SET•/MEDIA/AUDIO/<in>/DACVOLUME.Balance=<balance_value>
- ◀ pw•/MEDIA/AUDIO/<in>/DACVOLUME.Balance=<balance_value>

Example

- ▶ SET /MEDIA/AUDIO/I6/DACVOLUME.Balance=-100
- ◀ pw /MEDIA/AUDIO/I6/DACVOLUME.Balance=-100

Parameters

<balance_value> The balance value can be set between -100 (left) and +100 (right). Zero balance means the center setting.

7.8. Advanced Audio Settings

INFO: Advanced audio setting commands are available in MMX8x4-HT400MC and MMX8x4-HT420M models.

7.8.1. Microphone Input Settings

INFO: Microphone input setting commands are available in MMX8x4-HT400MC (for I9 audio port) and MMX8x4-HT420M (for I9 audio port) model.

7.8.1.1. Mute on Microphone Input

Command and Response

- ▶ SET•/MEDIA/AUDIO/I9.Mute=<mute_status>
- ◀ pw•/MEDIA/AUDIO/I9.Mute=<mute_status>

Parameters

<mute_status> **true:** muted;
 false: unmuted

Example

- ▶ SET /MEDIA/AUDIO/I9.Mute=true
- ◀ pw /MEDIA/AUDIO/I9.Mute=true

7.8.1.2. Set the Volume with Exact Value on Microphone Input

This command sets the volume in dB.

Command and Response

- ▶ SET•/MEDIA/AUDIO/I9.Volume=<volume_dB>
- ◀ pw•/MEDIA/AUDIO/I9.Volume=<volume_dB>

Parameters

<volume_dB> Volume can be set between -80.00dB and 10.00dB, but the it will be rounded for fix values:

-80.00; -60.00; -50.00; -40.00; -35.00; -25.00; -20.00; -15.00; -12.00; -9.00; -6.00; -3.00; 0.00; 3.00; 6.00; 10.00.

Example

- ▶ SET /MEDIA/AUDIO/I9.Volume=-8
- ◀ pw /MEDIA/AUDIO/I9.Volume=-6.00

7.8.1.3. Set the Volume by Step Value - Volume up

This command increases the volume in dB by one step on the fix value list (see the list in the previous section).

Command and Response

- ▶ CALL•/MEDIA/AUDIO/I9:volumeUp()
- ◀ m0•/MEDIA/AUDIO/I9:volumeUp()

Example

- ▶ CALL /MEDIA/AUDIO/I9:volumeUp()
- ◀ m0 /MEDIA/AUDIO/I9:volumeUp

7.8.1.4. Set the Volume by Step Value - Volume down

This command decreases the volume in decibel by one step on the fix value list (see the value list in the [Set the Volume with Exact Value on Microphone Input](#) section).

Command and Response

- ▶ CALL•/MEDIA/AUDIO/I9:volumeDown()
- ◀ m0•/MEDIA/AUDIO/I9:volumeDown()

Example

- ▶ CALL /MEDIA/AUDIO/I9:volumeDown()
- ◀ m0 /MEDIA/AUDIO/I9:volumeDown

7.8.1.5. Set the Panorama on the Microphone Input

Command and Response

- ▶ SET•/MEDIA/AUDIO/I9.Panorama=<pan_set>
- ◀ pw•/MEDIA/AUDIO/I9.Panorama=<pan_set>

Parameters

Identifier	Parameter description	Parameter values
<pan_set>	Panorama setting	R1-R6: Right channel, value can be set between 1 and 6. L1-L6: Left channel, value can be set between 1 and 6. 0: Center

Example

- ▶ SET /MEDIA/AUDIO/I9.Panorama=L6
- ◀ pw /MEDIA/AUDIO/I9.Panorama=L6

Microphone sound will be transmitted to the left channel of the audio output.

INFO: L1 and R1 are near the center, L6 means the maximum left side, R6 means the maximum right side.

7.8.1.6. Query the Gain on the Microphone Input

Command and Response

- ▶ GET•/MEDIA/AUDIO/I9.InputGain
- ◀ pw•/MEDIA/AUDIO/I9.InputGain=<gain_value>

Parameters

<gain_value> Microphone input gain in dB.

Example

- ▶ GET /MEDIA/AUDIO/I9.InputGain
- ◀ pw /MEDIA/AUDIO/I9.InputGain=1.00

7.8.1.7. Set the Gain n the Microphone Input

Command and Response

- ▶ SET•/MEDIA/AUDIO/I9.InputGain=<gain_value>
- ◀ pw•/MEDIA/AUDIO/I9.InputGain=<gain_value>

Parameters

<gain_value> Gain value can be set between -12dB and +55dB (1 dB step).

Example

- ▶ SET /MEDIA/AUDIO/I9.InputGain=1
- ◀ pw /MEDIA/AUDIO/I9.InputGain=1.00

7.8.1.8. Switch on the Phantom Power

WARNING! Phantom power supplies the condenser microphone by 48V via the microphone cable which is necessary for normal operation of the condenser microphone. Application of the phantom power can cause a damage if dynamic or wireless microphone is connected.

Command and Response

- ▶ SET•/MEDIA/AUDIO/I9.PhantomPower=<phantom_status>
- ◀ pw•/MEDIA/AUDIO/I9.PhantomPower=<phantom_status>

Parameters

<phantom_status> **true:** Phantom power is switched on.
 false: Phantom power is switched off.

Example

- ▶ SET /MEDIA/AUDIO/I9.PhantomPower=true
- ◀ pw /MEDIA/AUDIO/I9.PhantomPower=true

See more details about using the phantom power in [Installation Guide for Connecting a Microphone](#) section.

7.8.1.9. Set the Phase Inverter on Microphone Input

Command and Response

- ▶ SET•/MEDIA/AUDIO/I9.InvertPhase=<invertphase_status>
- ◀ pw•/MEDIA/AUDIO/I9.InvertPhase=<invertphase_status>

Parameters

<invertphase_status> **true:** Invert Phase is turned on.
 false: Invert Phase is turned off.

Example

- ▶ SET /MEDIA/AUDIO/I9.InvertPhase=true
- ◀ pw /MEDIA/AUDIO/I9.InvertPhase=true

For more details about the Phase Inverter see [Legend of Microphone Input Channel](#) section.

7.8.1.10. Set the Feedback on Microphone Input

Command and Response

- ▶ SET•/MEDIA/AUDIO/I9.FeedbackCancel=<feedback_status>
- ◀ pw•/MEDIA/AUDIO/I9.FeedbackCancel=<feedback_status>

Parameters

<feedback_status> **true:** Feedback cancel is on.
 false: Feedback cancel is off.

Example

- ▶ SET /MEDIA/AUDIO/I9.FeedbackCancel=true
- ◀ pw /MEDIA/AUDIO/I9.FeedbackCancel=true

For more details about the Feedback cancel see [Legend of Microphone Input Channel](#) section.

7.8.1.11. Set the Highpass Filter on Microphone Input

Command and Response

- ▶ SET•/MEDIA/AUDIO/I9.HPF=<hpf_status>
- ◀ pw•/MEDIA/AUDIO/I9.HPF=<hpf_status>

Parameters

<hpf_status> **true:** Highpass filter is on.
 false: Highpass filter is off.

Example

- ▶ SET /MEDIA/AUDIO/I9.HPF=true
- ◀ pw /MEDIA/AUDIO/I9.HPF=true

For more details about the Highpass Filter see [Legend of Microphone Input Channel](#) section.

7.8.1.12. Set the Lowpass Filter on Microphone Input

Command and Response

- ▶ SET•/MEDIA/AUDIO/I9.LPF=<lpf_status>
- ◀ pw•/MEDIA/AUDIO/I9.LPF=<lpf_status>

Parameters

<lpf_status> **true:** Lowpass filter is on.
 false: Lowpass filter is off.

Example

- ▶ SET /MEDIA/AUDIO/I9.LPF=true
- ◀ pw /MEDIA/AUDIO/I9.LPF=true

For more details about the Lowpass Filter see [Legend of Microphone Input Channel](#) section.

7.8.1.13. Equalizer (EQ) Settings on Microphone Input

Command and Response

- ▶ SET•/MEDIA/AUDIO/I9.<eq_nr>Gain=<gain_value>
- ◀ pw•/MEDIA/AUDIO/I9.<eq_nr>Gain=<gain_value>

Parameters

Identifier	Parameter values
<eq_nr>	PEQ1: Low (120 Hz) PEQ2: Lmid (400 Hz) PEQ3: Hmid: (1.6 kHz) PEQ4: High: (12 kHz)
<gain_value>	The EQ gain value can be set between -18dB and +18dB, in step of 3.00 dB. The value is rounded down if necessary to match with the step value. For more details, see Equalization (EQ) Settings .

Example

- ▶ SET /MEDIA/AUDIO/I9.PEQ1Gain=-16
- ◀ pw /MEDIA/AUDIO/I9.PEQ1Gain=-18.00

7.8.1.14. Load Factory Mic Preset

Command and Response

- ▶ SET•/MEDIA/AUDIO/I9.MicPreset=<preset_nr>
- ◀ pw•/MEDIA/AUDIO/I9.MicPreset =<preset_nr>

Parameters

Identifier	Parameter values
<preset_nr>	0: Manual 1: None 2: Lavarier (condenser) 3: Boundary (condenser) 4: Gooseneck 5:e945 (dynamic) 6: SM58 (dynamic)

Example

- ▶ SET /MEDIA/AUDIO/I9.MICPreset=3
- ◀ pw /MEDIA/AUDIO/I9.MICPreset=3

For more details about the microphone factory presets see [Factory MIC presets](#) section.

ATTENTION! When MicPreset property is set **2-6**, EQ settings can be modified only with LW3 commands, but it has no immediate effect to the microphone sound. They became valid when MicPreset property is set **0-1**.

7.8.2. Advanced Analog Audio Input

INFO: Advanced analog audio input setting commands are available in MMX8x4-HT400MC (for I10 audio port) and MMX8x4-HT420M (for I10 audio port) model.

7.8.2.1. Mute the Advanced Analog In

Command and Response

- ▶ SET•/MEDIA/AUDIO/I10.Mute=<mute_status>
- ◀ pw•/MEDIA/AUDIO/I10.Mute=<mute_status>

Parameters

<mute_status> **true:** muted;
 false: unmuted

Example

- ▶ SET /MEDIA/AUDIO/I10.Mute=true
- ◀ pw /MEDIA/AUDIO/I10.Mute=true

7.8.2.2. Set the Volume with Exact Value on Advanced Analog In

This command sets the volume in dB.

Command and Response

- ▶ SET•/MEDIA/AUDIO/I10.Volume=<volume_dB>
- ◀ pw•/MEDIA/AUDIO/I10.Volume=<volume_dB>

Parameters

<volume_dB> Volume can be set between -80.00dB and 10.00dB, but the it will be rounded for fix values:

-80.00; -60.00; -50.00; -40.00; -35.00; -25.00; -20.00; -15.00; -12.00; -9.00; -6.00; -3.00; 0.00; 3.00; 6.00; 10.00.

Example

- ▶ SET /MEDIA/AUDIO/I10.Volume=-8
- ◀ pw /MEDIA/AUDIO/I10.Volume=-6.00

7.8.2.3. Set the Volume by Step Value - Volume up

This command increases the volume in decibel by one step on the fix value list (see the list in the previous section).

Command and Response

- ▶ CALL•/MEDIA/AUDIO/I10:volumeUp()
- ◀ m0•/MEDIA/AUDIO/I10:volumeUp()

Example

- ▶ CALL /MEDIA/AUDIO/I10:volumeUp()
- ◀ m0 /MEDIA/AUDIO/I10:volumeUp

7.8.2.4. Set the Volume by Step Value - Volume down

This command decreases the volume in dB by one step on the fix value list (see the value list in the [Set the Volume with Exact Value on Advanced Analog In](#) section).

Command and Response

- ▶ CALL•/MEDIA/AUDIO/I10:volumeDown()
- ◀ m0•/MEDIA/AUDIO/I10:volumeDown()

Example

- ▶ CALL /MEDIA/AUDIO/I10:volumeDown()
- ◀ m0 /MEDIA/AUDIO/I10:volumeDown

7.8.2.5. Set the Balance on the Advanced Analog In

Command and Response

- ▶ SET•/MEDIA/AUDIO/I10.Balance=<bal_set>
- ◀ pw•/MEDIA/AUDIO/I10.Balance=<bal_set>

Parameters

Identifier	Parameter description	Parameter values
<bal_set>	Balance setting	R1-R6: Right channel, value can be set between 1 and 6. L1-L6: Left channel, value can be set between 1 and 6. 0: Center

Example

- ▶ SET /MEDIA/AUDIO/I10.Balance=L6
- ◀ pw /MEDIA/AUDIO/I10.Balance=L6

Audio sound will be transmitted to the left channel of the audio output.

INFO: L1 and R1 are near the center, L6 means the maximum left side, R6 means the maximum right side.

7.8.2.6. Query the Gain on the Advanced Analog In

Command and Response

- ▶ GET•/MEDIA/AUDIO/I10.InputGain
- ◀ pw•/MEDIA/AUDIO/I10.InputGain=<gain_value>

Parameters

<gain_value> Analog audio input gain in dB.

Example

- ▶ GET /MEDIA/AUDIO/I10.InputGain
- ◀ pw /MEDIA/AUDIO/I10.InputGain=0.00

7.8.2.7. Set the Gain on the Advanced Analog In

Command and Response

- ▶ SET•/MEDIA/AUDIO/I10.InputGain=<gain_value>
- ◀ pw•/MEDIA/AUDIO/I10.InputGain=<gain_value>

Parameters

<gain_value> The gain value can be set between -12dB and +21dB, in step of 3.00dB. The value is rounded down if necessary to match with the step value.

Example

- ▶ SET /MEDIA/AUDIO/I10.InputGain=1
- ◀ pw /MEDIA/AUDIO/I10.InputGain=1.00

7.8.2.8. Set the Phase Invert on Advanced Analog In

Command and Response

- ▶ SET•/MEDIA/AUDIO/I10.InvertPhase=<invertphase_status>
- ◀ pw•/MEDIA/AUDIO/I10.InvertPhase=<invertphase_status>

Parameters

<invertphase_status> **true:** Invert phase is on;
false: Invert phase is off.

Example

- ▶ SET /MEDIA/AUDIO/I10.InvertPhase=true
- ◀ pw /MEDIA/AUDIO/I10.InvertPhase=true

For more details about the Phase Invert feature see [Advanced Analog Input Channel](#) section.

7.8.2.9. Set the Highpass Filter on Advanced Analog In

Command and Response

- ▶ SET•/MEDIA/AUDIO/I10.HPF=<hpf_status>
- ◀ pw•/MEDIA/AUDIO/I10.HPF=<hpf_status>

Example

- ▶ SET /MEDIA/AUDIO/I10.HPF=true
- ◀ pw /MEDIA/AUDIO/I10.HPF=true

<hpf_status> **true:** Highpass filter is on.
 false: Highpass filter is off.

For more details about the Highpass Filter see [Legend of Microphone Input Channel](#) section.

7.8.2.10. Set the Lowpass Filter on Advanced Analog In

Command and Response

- ▶ SET•/MEDIA/AUDIO/I10.LPF=<lpf_status>
- ◀ pw•/MEDIA/AUDIO/I10.LPF=<lpf_status>

Parameters

<lpf_status> **true:** Lowpass filter is on.
 false: Lowpass filter is off.

Example

- ▶ SET /MEDIA/AUDIO/I10.LPF=true
- ◀ pw /MEDIA/AUDIO/I10.LPF=true

For more details about the Lowpass Filter see [Legend of Microphone Input Channel](#) section.

7.8.2.11. Equalizer (EQ) Settings on Advanced Analog In

Command and Response

- ▶ SET•/MEDIA/AUDIO/I10.<eq_nr>Gain=<gain_value>
- ◀ pw•/MEDIA/AUDIO/I10.<eq_nr>Gain=<gain_value>

Parameters

Identifier	Parameter values
<eq_nr>	PEQ1: Low (100 Hz)PEQ2: Lmid (400 Hz) PEQ3: Hmid: (1.6 kHz) PEQ4: High: (8 kHz)
<gain_value>	The EQ gain value can be set between -18dB and +18dB, in step of 3.00 dB. The value is rounded down if necessary to match with the step value. For more details, see Equalization (EQ) Settings .

Example

- ▶ SET /MEDIA/AUDIO/I10.PEQ1Gain=-16
- ◀ pw /MEDIA/AUDIO/I10.PEQ1Gain=-15.00

For more details, see [Equalization \(EQ\) Settings](#).

7.8.3. Embedded Audio Input Settings

INFO: Embedded audio input setting commands are available in MMX8x4-HT400MC and MMX8x4-HT420M model. The settings refer to the chosen embedded audio channel in the audio mixer. See more details in [Audio Interface](#) section.

7.8.3.1. Set the Audio Channel

Command and Response

- ▶ SET•/MEDIA/AUDIO/I11.AudioSource=<in><a_v>
- ◀ pw•/MEDIA/AUDIO/I11.AudioSource=<in><a_v>

Parameters

<a_v> A: Embed from AUX audio
 V: HDMI audio

Example

- ▶ SET /MEDIA/AUDIO/I11.AudioSource=I5A
- ◀ pw /MEDIA/AUDIO/I11.AudioSource=I5A

Embedded analog audio of I5 port is chosen.

ATTENTION! This setting affects to the crosspoint state.

7.8.3.2. Query the Sampling Frequency

Command and Response

- ▶ GET•/MEDIA/AUDIO/<in>.SamplingFreq
- ◀ pr•/MEDIA/AUDIO/<in>.SamplingFreq=<sampling_frequency>

Parameters:

<sampling_frequency> 0=44.1kHz; 1=undefined; 2=48kHz;
 3=32kHz; 4=22.05kHz; 6=24kHz;
 8=88.2kHz; 9=768kHz; A=96kHz;
 C=176.4 kHz; E=192kHz; F=unknown

Example

- ▶ GET /MEDIA/AUDIO/I6.SamplingFreq
- ◀ pr /MEDIA/AUDIO/I6.SamplingFreq=0

Sampling Frequency of the I6 is 44.1kHz.

7.8.3.3. Mute the Emb. Audio In

Command and Response

- ▶ SET•/MEDIA/AUDIO/I11.Mute=<mute_status>
- ◀ pw•/MEDIA/AUDIO/I11.Mute=<mute_status>

Parameters

<mute_status> **true:** muted;
 false: unmuted

Example

- ▶ SET /MEDIA/AUDIO/I11.Mute=true
- ◀ pw /MEDIA/AUDIO/I11.Mute=true

7.8.3.4. Set the Volume with Exact Value on the Emb. Audio In

This command sets the volume in dB.

Command and Response

- ▶ SET•/MEDIA/AUDIO/I11.Volume=<volume_dB>
- ◀ pw•/MEDIA/AUDIO/I11.Volume=<volume_dB>

Example

- ▶ SET /MEDIA/AUDIO/I11.Volume=-8
- ◀ pw /MEDIA/AUDIO/I11.Volume=-6.00

Parameters:

<volume_dB> Volume can be set between -80.00dB and 10.00dB, but the it will be rounded for fix values:
 -80.00; -60.00; -50.00; -40.00; -35.00; -25.00; -20.00; -15.00; -12.00;
 -9.00; -6.00; -3.00; 0.00; 3.00; 6.00; 10.00.

7.8.3.5. Set the Volume by Step Value - Volume up

This command increases the volume in dB by one step on the fix value list (see the list in the previous section).

Command and Response

- ▶ CALL•/MEDIA/AUDIO/I11:volumeUp()
- ◀ m0•/MEDIA/AUDIO/I11:volumeUp()

Example

- ▶ CALL /MEDIA/AUDIO/I11:volumeUp()
- ◀ m0 /MEDIA/AUDIO/I11:volumeUp

7.8.3.6. Set the Volume by Step Value - Volume down

This command decreases the volume in dB by one step on the fix value list (see the value list in the [Set the Volume with Exact Value on the Emb. Audio In](#) section).

Command and Response

- ▶ CALL•/MEDIA/AUDIO/I11:volumeDown()
- ◀ m0•/MEDIA/AUDIO/I11:volumeDown()

Example

- ▶ CALL /MEDIA/AUDIO/I11:volumeDown()
- ◀ m0 /MEDIA/AUDIO/I11:volumeDown

7.8.3.7. Set the Balance on the Emb. Audio In

Command and Response

- ▶ SET•/MEDIA/AUDIO/I11.Balance=<bal_set>
- ◀ pw•/MEDIA/AUDIO/I11.Balance=<bal_set>

Parameters

Identifier	Parameter description	Parameter values
<bal_set>	Balance setting	R1-R6: Right channel, value can be set between 1 and 6. L1-L6: Left channel, value can be set between 1 and 6. 0: Center

Example

- ▶ SET /MEDIA/AUDIO/I11.Balance=L6
- ◀ pw /MEDIA/AUDIO/I11.Balance=L6

Audio sound will be transmitted to the left channel of the audio output.

INFO: L1 and R1 are near the center, L6 means the maximum left side, R6 means the maximum right side.

7.8.3.8. Set the Phase Invert on the Emb. Audio In

Command and Response

- ▶ SET•/MEDIA/AUDIO/I11.InvertPhase=<invertphase_status>
- ◀ pw•/MEDIA/AUDIO/I11.InvertPhase=<invertphase_status>

Parameters

<invertphase_status> **true:** Invert phase is on;
false: Invert phase is off.

Example

- ▶ SET /MEDIA/AUDIO/I11.InvertPhase=true
- ◀ pw /MEDIA/AUDIO/I11.InvertPhase=true

For more details about the Phase Invert feature see [Legend of Embedded or Advanced Input Channel](#) section.

7.8.3.9. Set the Duck on the Emb. Audio In

Command and Response

- ▶ SET•/MEDIA/AUDIO/I11.Ducker=<duck_status>
- ◀ pw•/MEDIA/AUDIO/I11.Ducker=<duck_status>

Parameters

<duck_status> **true:** Duck function is on;
false: Duck function is off.

Example

- ▶ SET /MEDIA/AUDIO/I11.Ducker=true
- ◀ pw /MEDIA/AUDIO/I11.Ducker=true

For more details about the Duck function see [Legend of Embedded or Advanced Input Channel](#) section.

7.8.3.10. Set the Highpass Filter on the Emb. Audio In

Command and Response

- ▶ SET•/MEDIA/AUDIO/I11.HPF=<hpf_status>
- ◀ pw•/MEDIA/AUDIO/I11.HPF=<hpf_status>

Parameters

<hpf_status> **true:** Highpass filter is on;
false: Highpass filter is off.

Example

- ▶ SET /MEDIA/AUDIO/I11.HPF=true
- ◀ pw /MEDIA/AUDIO/I11.HPF=true

For more details about the Highpass Filter see [Legend of Microphone Input Channel](#) section.

7.8.3.11. Set the Lowpass Filter on the Emb. Audio In

Command and Response

- ▶ SET•/MEDIA/AUDIO/I11.LPF=<lpf_status>
- ◀ pw•/MEDIA/AUDIO/I11.LPF=<lpf_status>

Parameters

<lpf_status> **true:** Lowpass filter is on;
false: Lowpass filter is off.

Example

- ▶ SET /MEDIA/AUDIO/I11.LPF=true
- ◀ pw /MEDIA/AUDIO/I11.LPF=true

For more details about the Lowpass Filter in [Legend of Microphone Input Channel](#) section.

7.8.3.12. Equalizer (EQ) Settings on the Emb. Audio In

Command and Response

- ▶ SET•/MEDIA/AUDIO/I11.<eq_nr>Gain=<gain_value>
- ◀ pw•/MEDIA/AUDIO/I11.<eq_nr>Gain=<gain_value>

Parameters

Identifier	Parameter values
<eq_nr>	PEQ1: Low (100 Hz) PEQ2: Lmid (400 Hz) PEQ3: Hmid: (1.6 kHz) PEQ4: High: (8 kHz)
<gain_value>	The EQ gain value can be set between -18dB and +18dB, in step of 3.00 dB. The value is rounded down if necessary to match with the step value. For more details, see Equalization (EQ) Settings .

Example

- ▶ SET /MEDIA/AUDIO/I11.PEQ1Gain=-16.00
- ◀ pw /MEDIA/AUDIO/I11.PEQ1Gain=-15.00

7.8.4. Advanced Analog Audio Output

INFO: Advanced analog audio output setting commands are available in MMX8x4-HT400MC and MMX8x4-HT420M model. The settings refer to the chosen advanced analog audio channel in the audio mixer. See more details in [Audio Interface](#) section.

7.8.4.1. Mute the Analog Audio Out

Command and Response

- ▶ SET•/MEDIA/AUDIO/O6.Mute=<mute_status>
- ◀ pw•/MEDIA/AUDIO/O6.Mute=<mute_status>

Parameters

<mute_status> **true:** muted;
 false: unmuted

Example

- ▶ SET /MEDIA/AUDIO/O6.Mute=true
- ◀ pw /MEDIA/AUDIO/O6.Mute=true

7.8.4.2. Set the Volume with Exact Value on Analog Audio Out

This command sets the volume in decibel.

Command and Response

- ▶ SET•/MEDIA/AUDIO/O6.Volume=<volume_dB>
- ◀ pw•/MEDIA/AUDIO/O6.Volume=<volume_dB>

Parameters

<volume_dB> Volume can be set between -80.00dB and 10.00dB, but the it will be rounded for fix values:

-80.00; -60.00; -50.00; -40.00; -35.00; -25.00; -20.00; -15.00; -12.00; -9.00; -6.00; -3.00; 0.00; 3.00; 6.00; 10.00.

Example

- ▶ SET /MEDIA/AUDIO/O6.Volume=-8
- ◀ pw /MEDIA/AUDIO/O6.Volume=-6.00

7.8.4.3. Set the Volume by Step Value - Volume up

This command increases the volume in decibel by one step on the fix value list (see the list in the previous section).

Command and Response

- ▶ CALL•/MEDIA/AUDIO/O6:volumeUp()
- ◀ m0•/MEDIA/AUDIO/O6:volumeUp()

Example

- ▶ CALL /MEDIA/AUDIO/O6:volumeUp()
- ◀ m0 /MEDIA/AUDIO/O6:volumeUp

7.8.4.4. Set the Volume by Step Value - Volume down

This command decreases the volume in decibel by one step on the fix value list (see the value list in the [Set the Volume with Exact Value on Analog Audio Out](#) section).

Command and Response

- ▶ CALL•/MEDIA/AUDIO/O6:volumeDown()
- ◀ m0•/MEDIA/AUDIO/O6:volumeDown()

Example

- ▶ CALL /MEDIA/AUDIO/O6:volumeDown()
- ◀ m0 /MEDIA/AUDIO/O6:volumeDown

7.8.4.5. Set the Balance on Analog Audio Out

Command and Response

- ▶ SET•/MEDIA/AUDIO/O6.Balance=<bal_set>
- ◀ pw•/MEDIA/AUDIO/O6.Balance=<bal_set>

Parameters

Identifier	Parameter description	Parameter values
<bal_set>	Balance setting	R1-R6: Right channel, value can be set between 1 and 6. L1-L6: Left channel, value can be set between 1 and 6. 0: Center

Example

- ▶ SET /MEDIA/AUDIO/O6.Balance=L6
- ◀ pw /MEDIA/AUDIO/O6.Balance=L6

Audio sound will be transmitted to the left channel of the audio output.

INFO: L1 and R1 are near the center, L6 means the maximum left side, R6 means the maximum right side.

7.8.4.6. Set the Phase Invert on Analog Audio Out

Command and Response

- ▶ SET•/MEDIA/AUDIO/O6.InvertPhase=<invertphase_status>
- ◀ pw•/MEDIA/AUDIO/O6.InvertPhase=<invertphase_status>

Parameters

<invertphase_status> **true:** Invert phase is on;
 false: Invert phase is off.

Example

- ▶ SET /MEDIA/AUDIO/O6.InvertPhase=true
- ◀ pw /MEDIA/AUDIO/O6.InvertPhase=true

For more details about the Phase Invert feature see [Legend of Advanced Analog Output Channel](#) section.

7.8.4.7. Set the Mono Function on Analog Audio Out

Command and Response

- ▶ SET•/MEDIA/AUDIO/O6.Monomix=<mono_status>
- ◀ pw•/MEDIA/AUDIO/O6.Monomix=<mono_status>

Parameters

<mono_status> **true:** Mono setting is switched on;
 false: Mono setting is switched off.

Example

- ▶ SET /MEDIA/AUDIO/O6.MonoMix=true
- ◀ pw /MEDIA/AUDIO/O6.MonoMix=true

For more details about the Mono setting see [Legend of Advanced Analog Output Channel](#) section.

7.8.4.8. Set the Delay on Analog Audio Out

Command and Response

- ▶ SET•/MEDIA/AUDIO/O6.Delay=<delay_status>
- ◀ pw•/MEDIA/AUDIO/O6.Delay=<delay_status>

Parameters

<delay_status> **true:** Delay is switched on;
 false: Delay is switched off.

Example

- ▶ SET /MEDIA/AUDIO/O6.Delay=true
- ◀ pw /MEDIA/AUDIO/O6.Delay=true

For more details about the Delay see [Legend of Advanced Analog Output Channel](#) section.

7.8.4.9. Set the Delay Time on Analog Audio Out

Command and Response

- ▶ SET•/MEDIA/AUDIO/O6.Delay=<delay_time>
- ◀ pw•/MEDIA/AUDIO/O6.Delay=<delay_time>

Parameters

<delay_time> The delay time is between 0 and 25 ms.

Example

- ▶ SET /MEDIA/AUDIO/O6.DelayTime=10
- ◀ pw /MEDIA/AUDIO/O6.DelayTime=10

For more details about the Delay time see [Legend of Advanced Analog Output Channel](#) section.

7.8.4.10. Equalizer (EQ) Settings on Analog Audio Out

Command and Response

- ▶ SET•/MEDIA/AUDIO/O6.<eq_nr>Gain=<gain_value>
- ◀ pw•/MEDIA/AUDIO/O6.<eq_nr>Gain=<gain_value>

Parameters

Identifier	Parameter values
<eq_nr>	PEQ1: Low (100 Hz) PEQ2: Lmid (400 Hz) PEQ3: Hmid: (1.6 kHz) PEQ4: High: (8 kHz)
<gain_value>	The EQ gain value can be set between -18dB and +18dB, in step of 3.00 dB. The value is rounded down if necessary to match with the step value. For more details, see Equalization (EQ) Settings .

Example

- ▶ SET /MEDIA/AUDIO/O6.PEQ1Gain=-16.00
- ◀ pw /MEDIA/AUDIO/O6.PEQ1Gain=-15.00

For more details, see [Equalization \(EQ\) Settings](#).

7.8.5. Audio Presets

7.8.5.1. Save a Preset

Command and Response

- ▶ CALL /PRESETS/MICADDON/<ch>:savePreset(<index>,<target_node>,<name>)
- ◀ m0 /PRESETS/MICADDON/<ch>:savePreset

Parameters

Identifier	Parameter description	Parameter values
<ch>	Audio channel	MICIN: Microphone Input LINEIN: Advanced Analog Audio Input HDMIIN: Embedded Audio Input LINEOUT: Advanced Analog Audio Output
<index>	Memory slot ID	1-8: It defines which memory slot to save a preset.
<target_node>	Audio port number	I9: Microphone Input (when the <ch> parameter is MICIN) I10: Advanced Analog Audio Input (when the <ch> parameter is LINEIN) I11: Embedded Audio Input (when the <ch> parameter is HDMIIN) O6: Advanced Analog Audio Output (when the <ch> parameter is LINEOUT)
<name>	Preset name	Up to 16 characters are allowed to name a Preset. Letters (A-Z and a-z), hyphen (-), underscore (_), and numbers (0-9) are accepted. Factory default names: User 1-8

Example

- ▶ CALL /PRESETS/MICADDON/MICIN:savePreset(6,I9,first_mic)
- ◀ m0 /PRESETS/MICADDON/MICIN:savePreset

7.8.5.2. Load a Preset

Command and Response

- ▶ CALL /PRESETS/MICADDON/<ch>:loadPreset(<index>,<target_node>)
- ◀ m0 /PRESETS/MICADDON/<ch>:loadPreset

Parameters

See the legend in the previous section.

Example

- ▶ CALL /PRESETS/MICADDON/MICIN:loadPreset(7,I9)
- ◀ m0 /PRESETS/MICADDON/MICIN:loadPreset

7.8.5.3. Delete a Preset

Command and Response

- ▶ CALL /PRESETS/MICADDON/<ch>:deletePreset(<index>)
- ◀ mO /PRESETS/MICADDON/<ch>:deletePreset

Parameters

See the legend in the [Save a Preset](#) section.

Example

- ▶ CALL /PRESETS/MICADDON/LINEOUT:deletePreset(7)
- ◀ mO /PRESETS/MICADDON/LINEOUT:deletePreset

7.8.6. Audio Scenes

7.8.6.1. Change the Scene Name

Command and Response

- ▶ SET /PRESETS/MICADDON/SCENES/<scene_id>.Name=<scene_name>
- ◀ pw /PRESETS/MICADDON/SCENES/<scene_id>.Name=<scene_name>

Parameters

Identifier	Parameter description	Parameter values
<scene_id>	Memory slot identifier	U1-8: It defines which memory slot name will change.
<scene_name>	Name of the scene	Up to 16 characters are allowed to name a Preset. Letters (A-Z and a-z), hyphen (-), underscore (_), and numbers (0-9) are accepted. Factory default: User 1-8

Example

- ▶ SET /PRESETS/MICADDON/SCENES/U5.Name=Meeting_room5
- ◀ pw /PRESETS/MICADDON/SCENES/U5.Name=Meeting_room5

7.8.6.2. Save a Scene

Command and Response

- ▶ CALL /PRESETS/MICADDON/SCENES:saveScene(<index>,I9,I10,I11,O6,<scene_name>)
- ◀ mO /PRESETS/MICADDON/SCENES:saveScene

Parameters

Identifier	Parameter description	Parameter values
<index>	Memory slot identifier	1-8: It defines which memory slot to save a scene.
<scene_name>	Name of the scene	Up to 16 characters are allowed to name a scene. Letters (A-Z and a-z), hyphen (-), underscore (_), and numbers (0-9) are accepted. Factory default: User 1-8

INFO: I9,I10,I11,O6 are the port numbers of the audio channels which values are saved into a scene. So these port numbers are always the same.

Example

- ▶ CALL /PRESETS/MICADDON/SCENES:saveScene(5,I9,I10,I11,O6,User 1)
- ◀ mO /PRESETS/MICADDON/SCENES:saveScene

7.8.6.3. Load a Scene

Command and Response

- ▶ CALL /PRESETS/MICADDON/SCENES:loadScene(<index>,I9,I10,I11,O6)
- ◀ mO /PRESETS/MICADDON/SCENES:loadScene

Parameters

Identifier	Parameter description	Parameter values
<index>	Memory slot identifier	1-8: It defines which memory slot to load a scene.

INFO: I9,I10,I11,O6 are the port numbers of the audio channels which values are saved into a scene. So these port numbers are always the same.

Example

- ▶ CALL /PRESETS/MICADDON/SCENES:loadScene(6,I9,I10,I11,O6)
- ◀ mO /PRESETS/MICADDON/SCENES:loadScene

7.8.6.4. Delete a Scene

Command and Response

- ▶ CALL /PRESETS/MICADDON/SCENES:deleteScene(<index>)
- ◀ mO /PRESETS/MICADDON/SCENES:deleteScene

Parameters

Identifier	Parameter description	Parameter values
<index>	Memory slot identifier	1-8: It defines which memory slot to delete a scene.

Example

- ▶ CALL /PRESETS/MICADDON/SCENES:deleteScene(6)
- ◀ mO /PRESETS/MICADDON/SCENES:deleteScene

7.9. Serial Port Settings

ATTENTION! MMX8x4 series handles many serial ports. The following parameters can be set individually on each port; the exact port numbering is listed in [Port Numbering](#) section.

7.9.1. Protocol Setting

Command and Response

- ▶ SET•/MEDIA/UART/<serial_port>.ControlProtocol=<cont_protocol>
- ◀ pw•/MEDIA/UART/<serial_port>.ControlProtocol=<cont_protocol>

Parameters

Identifier	Parameter description	Parameter values
<serial_port>	Serial port number	P1-P10*
<cont_protocol>	Selected protocol	0: LW2 1: LW3

*The number of the ports depends on the model type. The exact port numbering is listed in [Port Numbering](#) section.

Example

- ▶ SET /MEDIA/UART/P1.ControlProtocol=1
- ◀ pw /MEDIA/UART/P1.ControlProtocol=1

7.9.2. BAUD Rate Setting

Command and Response

- ▶ SET•/MEDIA/UART/<serial_port>.Baudrate=<baudrate>
- ◀ pw•/MEDIA/UART/<serial_port>.Baudrate=<baudrate>

Parameters

Identifier	Parameter description	Parameter values
<serial_port>	Serial port number	P1-P10*
<baudrate>	Baud rate value	0: 4800; 1: 7200; 2: 9600 3: 14400; 4: 19200; 5: 38400 6: 57600; 7: 115200

*The number of the ports depends on the model type. The exact port numbering is listed in [Port Numbering](#) section.

Example

- ▶ SET /MEDIA/UART/P1.Baudrate=2
- ◀ pw /MEDIA/UART/P1.Baudrate=2

7.9.3. Operation Mode Setting

Command and Response

- ▶ SET•/MEDIA/UART/<serial_port>.Rs232Mode=<rs232_mode>
- ◀ pw•/MEDIA/UART/<serial_port>.Rs232Mode=<rs232_mode>

Parameters

Identifier	Parameter description	Parameter values
<serial_port>	Serial port number	P1-P10*
<rs232_mode>	RS-232 operation mode	0: Disconnect 1: Control 2: Command injection

*The number of the ports depends on the model type. The exact port numbering is listed in [Port Numbering](#) section.

Example

- ▶ SET /MEDIA/UART/P2.Rs232Mode=1
- ◀ pw /MEDIA/UART/P2.Rs232Mode=1

7.9.4. Command Injection Mode

Command and Response

- ▶ SET•/MEDIA/UART/<serial_port>.CommandInjectionEnable=<ci_stat>
- ◀ pw•/MEDIA/UART/<serial_port>.CommandInjectionEnable=<ci_stat>

Parameters

Identifier	Parameter description	Parameter values
<serial_port>	Serial port number	P1-P10*
<ci_enable>	Command injection status	true: Command injection enable false: Command injection disable

*The number of the ports depends on the model type. The exact port numbering is listed in [Port Numbering](#) section.

Example

- ▶ SET /MEDIA/UART/P2.CommandInjectionEnable=true
- ◀ pw /MEDIA/UART/P2.CommandInjectionEnable=true

ATTENTION! The Command injection status is stored in another read-only property which is True if both above mentioned properties are set to the proper state; if so, Command injection mode is active: /MEDIA/UART/<serial_port>.CommandInjectionStatus.

ATTENTION! Do not forget to set the TCP/IP port setting which is individual for each RS-232 port and stored in /MEDIA/UART/<serial_port>.CommandInjectionPort parameter.

7.9.5. Query the RS-232 Command Injection Port Number

Command and Response

- ▶ GET•/MEDIA/UART/<serial_port>.CommandInjectionPort
- ◀ pw•/MEDIA/UART/<serial_port>.CommandInjectionPort

Example

- ▶ GET /MEDIA/UART/P1.CommandInjectionPort
- ◀ pw /MEDIA/UART/P1.CommandInjectionPort=8001

7.10. IR Port Settings

7.10.1. Enable the IR Port

Command and Response

- ▶ SET•/MEDIA/IR/<ir_port>.Enable=<ir_port_staus>
- ◀ pw•/MEDIA/IR/<ir_port>.Enable=<ir_port_staus>

Parameters

Identifier	Parameter description	Parameter values
<ir_port>	IR port number	D1-D6*
<ir_port_staus>	IR port status	true: Enable false: Disable

*The number of the ports depends on the model type. The exact port numbering is listed in [Port Numbering](#) section.

Example

- ▶ SET /MEDIA/IR/D1.Enable=true
- ◀ pw /MEDIA/IR/D1.Enable=true

7.10.2. Query the IR Command Injection Port Number

Command and Response

- ▶ GET•/MEDIA/IR/<ir_port>.CommandInjectionPort
- ◀ pw•/MEDIA/IR/<ir_port>.CommandInjectionPort

Example

- ▶ GET /MEDIA/IR/D1.CommandInjectionPort
- ◀ pw /MEDIA/IR/D1.CommandInjectionPort

7.11. Relay Port Settings

7.11.1. Set Relay Connection Status

INFO: This command is available in MMX8x4-HT420M model.

Command and Response

- ▶ SET•/MEDIA/RELAY/<relay_port>.Output=<relay_status>
- ◀ pw•/MEDIA/RELAY/<relay_port>.Output=<relay_status>

Parameters

Identifier	Parameter description	Parameter values
<relay_port>	Relay port number	P1-P4
<relay_staus>	Relay port status	O: Open C: Close

Example

- ▶ SET /MEDIA/RELAY/P1.Output=C
- ◀ pw /MEDIA/RELAY/P1.Output=C

P1 relay port is set to be closed.

7.12. GPIO Port Settings

INFO: This command is available in MMX8x4-HT420M model.

7.12.1. Set the Direction of a GPIO Pin

Command and Response

- ▶ SET•/MEDIA/GPIO/<gpio_port>.Direction=<dir>
- ◀ pw•/MEDIA/GPIO/<gpio_port>.Direction=<dir>

Parameters

<dir> I: input direction of the GPIO pin
O: output direction of the GPIO pin

Example

- ▶ SET /MEDIA/GPIO/P1.Direction=I
- ◀ pw /MEDIA/GPIO/P1.Direction=I

7.12.2. Set the Output Level of a GPIO Pin

Command and Response

- ▶ SET•/MEDIA/GPIO/<gpio_port>.Output=<value>
- ◀ pw•/MEDIA/GPIO/<gpio_port>.Output=<value>

Parameters

Identifier	Parameter description	Parameter values
<gpio_port>	GPIO port number	P1-P6
<value>	Value of the GPIO pin	H: High level L: Low level

Example

- ▶ SET /MEDIA/GPIO/P1.Output=H
- ◀ pw /MEDIA/GPIO/P1.Output=H

7.12.3. Toggle the Level of a GPIO Pin

Command and Response

- ▶ CALL•/MEDIA/GPIO/<gpio_port>:toggle()
- ◀ pw•/MEDIA/GPIO/ <gpio_port>:toggle

Example

- ▶ CALL /MEDIA/GPIO/P1:toggle()
- ◀ mO /MEDIA/GPIO/P1:toggle

If the direction of the pin is input: the output value is toggled.

If the direction of the pin is output: the output value and the input value are toggled.

7.13. Network Configuration

7.13.1. Query the Current IP Address

Command and Response

- ▶ GET•/MANAGEMENT/NETWORK.IpAddress
- ◀ pr•/MANAGEMENT/NETWORK.IpAddress=<ip_address>

Example

- ▶ GET /MANAGEMENT/NETWORK.IpAddress
- ◀ pr /MANAGEMENT/NETWORK.IpAddress=192.168.0.100

7.13.2. Query the Current DHCP Status

Command and Response

- ▶ GET•/MANAGEMENT/NETWORK.DhcpEnabled
- ◀ pw•/MANAGEMENT/NETWORK.DhcpEnabled=<dhcp_status>

Parameters

<dhcp_status> **true:** The current IP address is DHCP.
false: The current IP address is fix.

Example

- ▶ GET /MANAGEMENT/NETWORK.DhcpEnabled
- ◀ pw /MANAGEMENT/NETWORK.DhcpEnabled=false

7.13.3. Set a Dynamic IP Address

Command and Response

- ▶ SET•/MANAGEMENT/NETWORK.DhcpEnabled=<dhcp_status>
- ◀ pw•/MANAGEMENT/NETWORK.DhcpEnabled=<dhcp_status>

Parameters

<dhcp_status> **true:** The dynamic IP address is set.
false: Fix IP address is set.

Example

- ▶ SET /MANAGEMENT/NETWORK.DhcpEnabled=true
- ◀ pw /MANAGEMENT/NETWORK.DhcpEnabled=true

7.13.4. Set a Static IP Address

Command and Response

- ▶ SET•/MANAGEMENT/NETWORK.StaticIpAddress=<IP_address>
- ◀ pw•/MANAGEMENT/NETWORK.StaticIpAddress=<IP_address>

Example

- ▶ SET /MANAGEMENT/NETWORK.StaticIpAddress=192.168.0.105
- ◀ pw /MANAGEMENT/NETWORK.StaticIpAddress=192.168.0.105

7.13.5. Change the Subnet Mask (Static)

Command and Response

- ▶ SET•/MANAGEMENT/NETWORK.StaticNetworkMask=<netmask>
- ◀ pw•/MANAGEMENT/NETWORK.StaticNetworkMask=<netmask>

Example

- ▶ SET /MANAGEMENT/NETWORK.StaticNetworkMask=255.255.255.0
- ◀ pw /MANAGEMENT/NETWORK.StaticNetworkMask=255.255.255.0

7.13.6. Change the Gateway Address (Static)

Command and Response

- ▶ SET•/MANAGEMENT/NETWORK.StaticGatewayAddress=<gw_address>
- ◀ pw•/MANAGEMENT/NETWORK.StaticGatewayAddress=<gw_address>

Example

- ▶ SET /MANAGEMENT/NETWORK.StaticGatewayAddress=192.168.0.5
- ◀ pw /MANAGEMENT/NETWORK.StaticGatewayAddress=192.168.0.5

7.13.7. Apply Network Settings

INFO: All network settings are executed after calling this function.

Command and Response

- ▶ CALL•/MANAGEMENT/NETWORK:ApplySettings(1)
- ◀ mO /MANAGEMENT/NETWORK:ApplySettings

Example

- ▶ CALL /MANAGEMENT/NETWORK:ApplySettings(1)
- ◀ mO /MANAGEMENT/NETWORK:ApplySettings

7.14. Sending Message via the Communication Ports

7.14.1. Sending Message via TCP Port

The device can be used for sending a message to a certain IP:port address. The three different commands allow controlling the connected (third-party) devices.

7.14.1.1. Sending a TCP Message (ASCII-format)

The command is for sending a command message in ASCII-format. This method allows escaping the control characters. For more information see the [Escaping](#) section.

Command and Response

- ▶ CALL•/MEDIA/ETHERNET:tcpMessage(<IP_address>:<port_no>=<message>)
- ◀ mO•/MEDIA/ETHERNET:tcpMessage

Example

- ▶ CALL /MEDIA/ETHERNET:tcpMessage(192.168.0.103:6107=C00)
- ◀ mO /MEDIA/ETHERNET:tcpMessage

The 'C00' message is sent to the indicated IP:port address.

Example with HEX codes

- ▶ CALL /MEDIA/ETHERNET:tcpMessage(192.168.0.20:5555=C00\x0a\x0d)
- ◀ mO /MEDIA/ETHERNET:tcpMessage

The 'C00' message with CrLf (Carriage return and Line feed) is sent to the indicated IP:port address. The \x sequence indicates the HEXA code; see more information in the [Using Hexadecimal Codes](#) section.

7.14.1.2. Sending a TCP Text (ASCII-format)

The command is for sending a text message in ASCII-format. This method **does not allow** escaping or inserting control characters.

Command and Response

- ▶ CALL•/MEDIA/ETHERNET:tcpText(<IP_address>:<port_no>=<text>)
- ◀ mO•/MEDIA/ETHERNET:tcpText

Example

- ▶ CALL /MEDIA/ETHERNET:tcpText(192.168.0.103:6107=pwr_on)
- ◀ mO /MEDIA/ETHERNET:tcpText

The 'pwr_on' text is sent to the indicated IP:port address.

7.14.1.3. Sending a TCP Binary Message (HEX-format)

The command is for sending a binary message in Hexadecimal format. This method **does not allow** escaping or inserting control characters.

Command and Response

- ▶ CALL•/MEDIA/ETHERNET:tcpBinary(<IP_address>:<port_no>=<HEX_message>)
- ◀ mO•/MEDIA/ETHERNET:tcpBinary

Example

- ▶ CALL /MEDIA/ETHERNET:tcpBinary(192.168.0.103:6107=010000006162000cdcc2c40)
- ◀ mO /MEDIA/ETHERNET:tcpBinary

The '010000006162000cdcc2c40' message is sent to the indicated IP:port address.

INFO: There is no need to insert a space or other separator character between the binary messages.

7.14.2. UDP Message Sending via Ethernet

The device can be used for sending a message to a certain IP:port address. The three different commands allow controlling the connected (third-party) devices.

7.14.2.1. Sending UDP Message (ASCII-format)

The command is for sending a UDP message in ASCII-format. This method allows escaping the control characters. For more information see the [Escaping](#) section.

Command and Response

- ▶ CALL•/MEDIA/ETHERNET:udpMessage(<IP_address>:<port_no>=<message>)
- ◀ mO•/MEDIA/ETHERNET:udpMessage

Example

- ▶ CALL /MEDIA/ETHERNET:udpMessage(192.168.0.103:6107=C00)
- ◀ mO /MEDIA/ETHERNET:udpMessage

The 'C00' message is sent to the indicated IP:port address.

Example with HEX codes

- ▶ CALL /MEDIA/ETHERNET:udpMessage(192.168.0.20:9988=C00\x0a\x0d)
- ◀ mO /MEDIA/ETHERNET:udpMessage

The 'C00' message with CrLf (Carriage return and Line feed) is sent to the indicated IP:port address. The \x sequence indicates the HEXA code; see more information in the [Using Hexadecimal Codes](#) section.

7.14.2.2. Sending a UDP Text (ASCII-format)

The command is for sending a text message in ASCII-format via UDP-protocol. This method **does not allow** escaping or inserting control characters.

Command and Response

- ▶ CALL•/MEDIA/ETHERNET:udpText(<IP_address>:<port_no>=<text>)
- ◀ mO•/MEDIA/ETHERNET:udpText

Example

- ▶ CALL /MEDIA/ETHERNET:udpText(192.168.0.20:9988=open)
- ◀ mO /MEDIA/ETHERNET:udpText

The 'open' text is sent to the indicated IP:port address.

7.14.2.3. Sending a UDP Binary Message (HEX-format)

The command is for sending a binary message in Hexadecimal format via UDP protocol. This method **does not allow** escaping or inserting control characters.

Command and Response

- ▶ CALL•/MEDIA/ETHERNET:udpBinary(<IP_address>:<port_no>=<HEX_message>)
- ◀ mO•/MEDIA/ETHERNET:udpBinary

Example

- ▶ CALL /MEDIA/ETHERNET:udpBinary(192.168.0.20:9988=433030)
- ◀ mO /MEDIA/ETHERNET:udpBinary

The '433030' message is sent to the indicated IP:port address.

■ INFO: There is no need to insert a space or other separator character between the binary messages.

7.14.3. Message Sending via RS-232 Serial Port

7.14.3.1. Sending a Message (ASCII-format) via RS-232

The command is for sending a command message in ASCII-format. This method **allows** escaping the control characters. For more information see the [Escaping](#) section.

Command and Response

- ▶ CALL•/MEDIA/UART/P1:sendMessage(<message>)
- ◀ mO•/MEDIA/UART/P1:sendMessage

Example

- ▶ CALL /MEDIA/UART/P1:sendMessage(PWR0)
- ◀ mO /MEDIA/UART/P1:sendMessage

The 'PWR0' message is sent out via the P1 serial port.

7.14.3.2. Sending a Text (ASCII-format) via RS-232

The command is for sending a command message in ASCII-format. This method **does not allow** escaping the control characters.

Command and Response

- ▶ CALL•/MEDIA/UART/P1:sendText(<message>)
- ◀ mO•/MEDIA/UART/P1:sendText

Example

- ▶ CALL /MEDIA/UART/P1:sendText(open)
- ◀ mO /MEDIA/UART/P1:sendText

The 'open' text is sent out via the P1 serial port.

7.14.3.3. Sending a Binary Message (HEX-format) via RS-232

The command is for sending a command message in Hexadecimal-format. This method **does not allow** escaping the control characters.

Command and Response

- ▶ CALL•/MEDIA/UART/P1:sendBinaryMessage(<message>)
- ◀ mO•/MEDIA/UART/P1:sendBinaryMessage

Example

- ▶ CALL /MEDIA/UART/P1:sendBinaryMessage(433030)
- ◀ mO /MEDIA/UART/P1:sendBinaryMessage

The '433030' message is sent out via the P1 serial port.

7.14.4. Using Hexadecimal Codes

Hexadecimal codes can be inserted in the ASCII message when using:

sendMessage command: CALL /MEDIA/UART/P1:sendMessage(C00\x0D)

tcpMessage command: CALL /MEDIA/ETHERNET:tcpMessage(C00\x0D)

udpMessage command: CALL /MEDIA/ETHERNET:udpMessage(C00\x0D)

- C00: the message.
- \x: indicates that the following is a hexadecimal code.
- 0D: the hexadecimal code (Carriage Return).

7.15.4. Hotplug Detect

This property indicates that the connected source or sink is connected.

Command and Response

- ▶ GET•/MEDIA/VIDEO/<port>.Power5vIn
- ◀ pr•/MEDIA/VIDEO/<port>.Power5vIn =<power5v_status>

Parameters

<power05v_status> **true:** Indicates 5V on the port.
false: 5V is not sensed on the port.

Example

- ▶ GET /MEDIA/VIDEO/I6.Power5vIn
- ◀ pr /MEDIA/VIDEO/I6.Power5vIn=true

7.15.5. Query Audio Indicators

INFO: Advanced analog audio output setting commands are available in MMX8x4-HT400MC and MMX8x4-HT420M model.

7.15.5.1. Query Audio Indicators for Microphone Input

It gives a feedback about the actual level of the microphone input signal.

For more details see [Panorama](#) or [Balance Settings](#) section.

Command and Response

- ▶ GET•/MEDIA/AUDIO/I9.<sign_level>
- ◀ pr•/MEDIA/AUDIO/I9.<sign_level>=<indicator_status>

Parameters

Identifier	Parameter description	Parameter values
<sign_level>	Actual level of the audio signal	IndicatorPeak: Peak level IndicatorNominal: Nominal level IndicatorSignal: Signal level
<indicator_status>	Indicator status	true: The audio signal reaches the <sign_level> false: The audio signal does not reach the <sign_level>

Example

- ▶ GET /MEDIA/AUDIO/I9.IndicatorPeak
- ◀ pr /MEDIA/AUDIO/I9.IndicatorPeak=true

The microphone input signal above the peak value.

7.15.5.2. Query Audio Indicators for Advanced Audio Ports

It gives a feedback about the actual level of the advanced analog input, embedded audio input and the advanced audio output signal. For more details see [Panorama](#) or [Balance Settings](#) section.

Command and Response

- ▶ GET•/MEDIA/AUDIO/<advanced_port>.<sign_level><ch>
- ◀ pr•/MEDIA/AUDIO/<advanced_port>.<sign_level><ch>=<status>

Example

- ▶ GET /MEDIA/AUDIO/O6.IndicatorPeakLeft
- ◀ pr /MEDIA/AUDIO/O6.IndicatorPeakLeft=false

Parameters

Identifier	Parameter description	Parameter values
<advanced_port>	Advanced analog audio port	I10: Advanced analog audio input I11: Embedded audio input O6: Advanced analog audio output
<sign_level>	Actual level of the audio signal	IndicatorPeak: Peak level IndicatorNominal: Nominal level IndicatorSignal: Signal level
<ch>		left: refers to the left channel right: refers to the right channel
<status>	Indicator status	true: The audio signal reaches the <sign_level> false: The audio signal does not reach the <sign_level>

7.15.6. Remote

INFO: These commands are available in MMX8x4-HT400MC and MMX8x4-HT420M models.

The **Remote** node contains some basic status information about the Lightware device which is connected to a TPS port of the matrix.

7.15.6.1. Query the Connection State of the Remote Device

This property indicates if the remote device connected or not.

Command and Response

- ▶ GET•/REMOTE/<port>.LinkState
- ◀ pr•/REMOTE/<port>.LinkState=<link_state>

Parameters

<link_state> **true:** The remote device is connected
false: The remote device is not connected

Example

- ▶ GET /REMOTE/S2.LinkState
- ◀ pr /REMOTE/S2.LinkState=true

7.15.6.2. Query Connected Device

Command and Response

- ▶ GET•/REMOTE/<port>.ConnectedDevice
- ◀ pr•/REMOTE/<port>.Connected=<device_name>

Example

- ▶ GET /REMOTE/S2.ConnectedDevice
- ◀ pr /REMOTE/S2.ConnectedDevice=UMX-TPS-TX140

7.15.6.3. Connected IP Address

This property indicates if the remote device connected or not.

Command and Response

- ▶ GET•/REMOTE/<port>.RemotelpAddress
- ◀ pr•/REMOTE/<port>.RemotelpAddress=<IP_address>

Example

- ▶ GET /REMOTE/S2.RemotelpAddress
- ◀ pr /REMOTE/S2.RemotelpAddress=192.168.0.105

7.16. LW3 Quick Summary

System Commands

Query the Product Name

- ▶ GET•/.ProductName

Query the Device Label

- ▶ SET•/MANAGEMENT/UID/DeviceLabel=<custom_name>

Set the Device Label

- ▶ SET•/MANAGEMENT/UID/DeviceLabel=<custom_name>

Query the Serial Number

- ▶ GET•/.SerialNumber

Setting the Rotary Direction of the Jog Dial Knob

- ▶ SET•/MANAGEMENT/UI.RotaryDirection=<direction>

Control Lock

- ▶ SET•/MANAGEMENT/UI.ControlLock=<control_state>

Identify the Device

- ▶ CALL•/MANAGEMENT/UI.identifyMe()

Resetting the Matrix

- ▶ CALL•/SYS:reset()

Restore the Factory Default Settings

- ▶ CALL•/SYS:factoryDefaults()

Switching and Crosspoint Settings

Query the Video Crosspoint State

- ▶ GET•/MEDIA/VIDEO/XP.DestinationConnectionList

Switching an Input to an Output

- ▶ CALL•/MEDIA/VIDEO/XP:switch(<in>:<out>)

Switching an Input to All Outputs

- ▶ CALL•/MEDIA/VIDEO/XP:switchAll(<in>)

Video Port Settings

Mute an Input Port

- ▶ CALL•/MEDIA/VIDEO/XP:muteSource(<in>)

Unmute an Input Port

- ▶ CALL•/MEDIA/VIDEO/XP:unmuteSource(<in>)

Mute an Output Port

- ▶ CALL•/MEDIA/VIDEO/XP:muteDestination(<out>)

Unmute an Output Port

- ▶ CALL•/MEDIA/VIDEO/XP:unmuteDestination(<out>)

Lock an Input Port

- ▶ CALL•/MEDIA/VIDEO/XP:lockSource(<in>)

Unlock an Input Port

- ▶ CALL•/MEDIA/VIDEO/XP:unlockSource(<in>)

Lock an Output Port

- ▶ CALL•/MEDIA/VIDEO/XP:lockDestination(<out>)

Unlock an Output Port

- ▶ CALL•/MEDIA/VIDEO/XP:unlockDestination(<out>)

HDCP Setting (Input Port)

- ▶ SET•/MEDIA/VIDEO/<In>.HdcpEnable=<hdcp_status>

HDCP Setting (Output Port)

- ▶ SET•/MEDIA/VIDEO/<On>.HdcpModeSetting=<hdcp_mode>

Query the Status of Source Port

- ▶ GET•/MEDIA/VIDEO/XP.SourcePortStatus

Query the Status of Destination Port

- ▶ GET•/MEDIA/XP/VIDEO.DestinationPortStatus

Query the Video Autoselect Settings

- ▶ GET•/MEDIA/VIDEO/XP.DestinationPortAutoselect

Change the Autoselect Mode

- ▶ CALL•/MEDIA/VIDEO/XP:setDestinationPortAutoselect(<out>:<out_set>)

Query the Input Port Priority

- ▶ GET•/MEDIA/VIDEO/XP.PortPriorityList

Changing the Input Port Priority

- ▶ CALL•/MEDIA/VIDEO/XP:setAutoselectionPriority(<in>\(<out>\):<prio>);(<in>\(<out>\):<prio>)

TPS Mode Settings on TPS Ports

- ▶ SET•/REMOTE/<tps_port>.tpsModeSetting=<tps_mode_setting>

Sending OSD String

- ▶ SET•/MEDIA/CEC/<port>.OsdString=<text>
- ▶ CALL /MEDIA/CEC/<port>:send(set_osd)

Send CEC Command in Text Format

- ▶ CALL /MEDIA/CEC/<port>:send(<command>)

Send CEC Command in Hexadecimal Format

- ▶ CALL /MEDIA/CEC/<port>:sendHex(<hex_code>)

PoE Enable

- ▶ SET•/REMOTE/<tps_port>.PoeEnabled=<poe_status>

Signal Type Settings (Output Ports)

- ▶ SET•/MEDIA/VIDEO/<out>.HdmiModeSetting=<signal_type>

Test Pattern**Test pattern generator mode setting**

- ▶ SET•/MEDIA/VIDEO/<out>.TpgMode=<tpg_mode>

Clock source – the clock frequency of the test pattern

- ▶ SET•/MEDIA/VIDEO/<out>.TpgClockSource=<tpg_clocksource>

Test pattern

- ▶ SET•/MEDIA/VIDEO/<out>.TpgPattern=<pattern>

EDID Management**Query the Emulated EDIDs**

- ▶ GET•/EDID.EdidStatus

Set the Emulated EDID

- ▶ CALL•/EDID:switch(<source>:<destination>)

Copy an EDID into Another Slot

- ▶ CALL•/EDID:copy(<source>:<destination>)

AUX Analog Audio I/O Port Settings**Audio Mode Setting**

- ▶ SET•/MEDIA/AUDIO/<in>.AudioMode=<audio_mode>

AUX Analog Audio Input Settings**Mute**

- ▶ SET•/MEDIA/AUDIO/<in>/ADCVOLUME.Mute=<mute_status>

Volume

- ▶ SET•/MEDIA/AUDIO/<in>/ADCVOLUME.VoluedB=<volume_dB>

Balance

- ▶ SET•/MEDIA/AUDIO/<in>/ADCVOLUME.Balance=<balance_value>

Gain

- ▶ SET•/MEDIA/AUDIO/<in>/ADCVOLUME.Gain=<gain_dB>

AUX Analog Audio Output Settings**Mute**

- ▶ SET•/MEDIA/AUDIO/<in>.DACVOLUME.Mute=<mute_status>

Volume

- ▶ SET•/MEDIA/AUDIO/<in>/DACVOLUME.VoluedB=<volume_dB>

Balance

- ▶ SET•/MEDIA/AUDIO/<in>/DACVOLUME.Balance=<balance_value>

Microphone Input Settings**Mute on Microphone Input**

- ▶ SET•/MEDIA/AUDIO/I9.Mute=<mute_status>

Set the Volume with Exact Value on Microphone Input

- ▶ SET•/MEDIA/AUDIO/I9.Volume=<volume_dB>

Set the Volume by Step Value - Volume up

- ▶ CALL•/MEDIA/AUDIO/I9:volumeUp()

Set the Volume by Step Value - Volume down

- ▶ CALL•/MEDIA/AUDIO/I9:volumeDown()

Set the Panorama on the Microphone Input

- ▶ SET•/MEDIA/AUDIO/I9.Panorama=<pan_set>

Query the Gain on the Microphone Input

- ▶ GET•/MEDIA/AUDIO/I9.InputGain

Set the Gain on the Microphone Input

- ▶ SET•/MEDIA/AUDIO/I9.InputGain=<gain_value>

Switch on the Phantom Power

- ▶ SET•/MEDIA/AUDIO/I9.PhantomPower=<phantom_status>

Set the Phase Inverter on Microphone Input

- ▶ SET•/MEDIA/AUDIO/I9.InvertPhase=<invertphase_status>

Set the Feedback on Microphone Input

- ▶ SET•/MEDIA/AUDIO/I9.FeedbackCancel=<feedback_status>

Set the Highpass Filter on Microphone Input

- ▶ SET•/MEDIA/AUDIO/I9.HPF=<hpf_status>

Set the Lowpass Filter on Microphone Input

- ▶ SET•/MEDIA/AUDIO/I9.LPF=<lpf_status>

Equalizer (EQ) Settings on Microphone Input

- ▶ SET•/MEDIA/AUDIO/I9.<eq_nr>Gain=<gain_value>

Load Factory Default Mic Preset

- ▶ SET•/MEDIA/AUDIO/I9.MicPreset=<preset_nr>

Advanced Analog Audio Input**Mute the Advanced Analog In**

- ▶ SET•/MEDIA/AUDIO/I10.Mute=<mute_status>

Set the Volume with Exact Value on Advanced Analog In

- ▶ SET•/MEDIA/AUDIO/I10.Volume=<volume_dB>

Set the Volume by Step Value - Volume up

- ▶ CALL•/MEDIA/AUDIO/I10:volumeUp()

Set the Volume by Step Value - Volume down

- ▶ CALL•/MEDIA/AUDIO/I10:volumeDown()

Set the Balance on the Advanced Analog In

- ▶ SET•/MEDIA/AUDIO/I10.Balance=<bal_set>

Query the Gain on the Advanced Analog In

- ▶ GET•/MEDIA/AUDIO/I10.InputGain

Set the Gain on the Advanced Analog In

- ▶ SET•/MEDIA/AUDIO/I10.InputGain=<gain_value>

Set the Phase Invert on Advanced Analog In

- ▶ SET•/MEDIA/AUDIO/I10.InvertPhase=<invertphase_status>

Set the Highpass Filter on Advanced Analog In

- ▶ SET•/MEDIA/AUDIO/I10.HPF=<hpf_status>

Set the Lowpass Filter on Advanced Analog In

- ▶ SET•/MEDIA/AUDIO/I10.LPF=<lpf_status>

Equalizer (EQ) Settings on Advanced Analog In

- ▶ SET•/MEDIA/AUDIO/I10.<eq_nr>Gain=<gain_value>

Embedded Audio Input Settings**Set the Audio Channel**

- ▶ SET•/MEDIA/AUDIO/I11.AudioSource=<in><a_v>

Query the Sampling Frequency

- ▶ GET•/MEDIA/AUDIO/<in>.SamplingFreq

Mute the Emb. Audio In

- ▶ SET•/MEDIA/AUDIO/I11.Mute=<mute_status>

Set the Volume with Exact Value on the Emb. Audio In

- ▶ SET•/MEDIA/AUDIO/I11.Volume=<volume_dB>

Set the Volume by Step Value - Volume up

- ▶ CALL•/MEDIA/AUDIO/I11:volumeUp()

Set the Volume by Step Value - Volume down

- ▶ CALL•/MEDIA/AUDIO/I11:volumeDown()

Set the Balance on the Emb. Audio In

- ▶ SET•/MEDIA/AUDIO/I11.Balance=<bal_set>

Set the Phase Invert on the Emb. Audio In

- ▶ SET•/MEDIA/AUDIO/I11.InvertPhase=<invertphase_status>

Set the Duck on the Emb. Audio In

- ▶ SET•/MEDIA/AUDIO/I11.Ducker=<duck_status>

Set the Highpass Filter on the Emb. Audio In

- ▶ SET•/MEDIA/AUDIO/I11.HPF=<hpf_status>

Set the Lowpass Filter on the Emb. Audio In

- ▶ SET•/MEDIA/AUDIO/I11.LPF=<lpf_status>

Equalizer (EQ) Settings on the Emb. Audio In

- ▶ SET•/MEDIA/AUDIO/I11.<eq_nr>Gain=<gain_value>

Advanced Analog Audio Output**Mute the Analog Audio Out**

▶ SET•/MEDIA/AUDIO/O6.Mute=<mute_status>

Set the Volume with Exact Value on Analog Audio Out

▶ SET•/MEDIA/AUDIO/O6.Volume=<volume_dB>

Set the Volume by Step Value - Volume up

▶ CALL•/MEDIA/AUDIO/O6:volumeUp()

Set the Volume by Step Value - Volume down

▶ CALL•/MEDIA/AUDIO/O6:volumeDown()

Set the Balance on Analog Audio Out

▶ SET•/MEDIA/AUDIO/O6.Balance=<bal_set>

Set the Phase Invert on Analog Audio Out

▶ SET•/MEDIA/AUDIO/O6.InvertPhase=<invertphase_status>

Set the Mono Function on Analog Audio Out

▶ SET•/MEDIA/AUDIO/O6.Monomix=<mono_status>

Set the Delay on Analog Audio Out

▶ SET•/MEDIA/AUDIO/O6.Delay=<delay_status>

Set the Delay Time on Analog Audio Out

▶ SET•/MEDIA/AUDIO/O6.Delay=<delay_time>

Equalizer (EQ) Settings on Analog Audio Out

▶ SET•/MEDIA/AUDIO/O6.<eq_nr>Gain=<gain_value>

Audio Presets**Save a Preset**

▶ CALL /PRESETS/MICADDON/<ch>:savePreset(<index>,<target_node>,<name>)

Load a Preset

▶ CALL /PRESETS/MICADDON/<ch>:loadPreset(<index>,<target_node>)

Delete a Preset

▶ CALL /PRESETS/MICADDON/<ch>:deletePreset(<index>)

Audio Scenes**Change the Scene Name**

▶ SET /PRESETS/MICADDON/SCENES/<scene_id>.Name=<scene_name>

Save a Scene

▶ CALL /PRESETS/MICADDON/SCENES:saveScene(<index>,I9,I10,I11,O6,<scene_name>)

Load a Scene

▶ CALL /PRESETS/MICADDON/SCENES:loadScene(<index>,I9,I10,I11,O6)

Delete a Scene

▶ CALL /PRESETS/MICADDON/SCENES:deleteScene(<index>)

Serial Port Settings**Protocol Setting**

▶ SET•/MEDIA/UART/<serial_port>.ControlProtocol=<cont_protocol>

BAUD Rate Setting

▶ SET•/MEDIA/UART/<serial_port>.Baudrate=<baudrate>

Operation Mode Setting

▶ SET•/MEDIA/UART/<serial_port>.Rs232Mode=<rs232_mode>

Command Injection Mode

▶ SET•/MEDIA/UART/<serial_port>.CommandInjectionEnable=<ci_stat>

Query the RS-232 Command Injection Port Number

▶ GET•/MEDIA/UART/<serial_port>.CommandInjectionPort

IR Port Settings**Enable the IR Port**

▶ SET•/MEDIA/IR/<ir_port>.Enable=<ir_port_staus>

Query the IR Command Injection Port Number

▶ GET•/MEDIA/IR/<ir_port>.CommandInjectionPort

Relay Port Settings**Set Relay Connection Status**

▶ SET•/MEDIA/RELAY/<relay_port>.Output=<relay_status>

GPIO Port Settings**Set the Direction of a GPIO Pin**

- ▶ SET•/MEDIA/GPIO/<gpio_port>.Direction=<dir>

Set the Output Level of a GPIO Pin

- ▶ SET•/MEDIA/GPIO/<gpio_port>.Output=<value>

Toggle the Level of a GPIO Pin

- ▶ CALL•/MEDIA/GPIO/<gpio_port>.toggle()

Network Configuration**Query the Current IP Address**

- ▶ GET•/MANAGEMENT/NETWORK.IpAddress

Query the Current DHCP Status

- ▶ GET•/MANAGEMENT/NETWORK.DhcpEnabled

Set a Dynamic IP Address

- ▶ SET•/MANAGEMENT/NETWORK.DhcpEnabled=<dhcp_status>

Set a Static IP Address

- ▶ SET•/MANAGEMENT/NETWORK.StaticIpAddress=<IP_address>

Change the Subnet Mask (Static)

- ▶ SET•/MANAGEMENT/NETWORK.StaticNetworkMask=<netmask>

Change the Gateway Address (Static)

- ▶ SET•/MANAGEMENT/NETWORK.StaticGatewayAddress=<gw_address>

Apply Network Settings

- ▶ CALL•/MANAGEMENT/NETWORK:ApplySettings(1)

Sending Message via the Communication Ports**Sending a TCP Message (ASCII-format)**

- ▶ CALL•/MEDIA/ETHERNET:tcpMessage(<IP_address>:<port_no>=<message>)

Sending a TCP Text (ASCII-format)

- ▶ CALL•/MEDIA/ETHERNET:tcpText(<IP_address>:<port_no>=<text>)

Sending a TCP Binary Message (HEX-format)

- ▶ CALL•/MEDIA/ETHERNET:tcpBinary(<IP_address>:<port_no>=<HEX_message>)

Sending UDP Message (ASCII-format)

- ▶ CALL•/MEDIA/ETHERNET:udpMessage(<IP_address>:<port_no>=<message>)

Sending a UDP Text (ASCII-format)

- ▶ CALL•/MEDIA/ETHERNET:udpText(<IP_address>:<port_no>=<text>)

Sending a UDP Binary Message (HEX-format)

- ▶ CALL•/MEDIA/ETHERNET:udpBinary(<IP_address>:<port_no>=<HEX_message>)

Sending a Message (ASCII-format) via RS-232

- ▶ CALL•/MEDIA/UART/P1:sendMessage(<message>)

Sending a Text (ASCII-format) via RS-232

- ▶ CALL•/MEDIA/UART/P1:sendText(<message>)

Sending a Binary Message (HEX-format) via RS-232

- ▶ CALL•/MEDIA/UART/P1:sendBinaryMessage(<message>)

Sending Pronto Hex Codes in Little-endian Format via IR Port

- ▶ CALL /MEDIA/IR/<ir_port>:sendProntoHex(<hex_code>)

Sending Pronto Hex Codes in Big-endian Format via IR Port

- ▶ CALL /MEDIA/IR/<ir_port>:sendProntoHexBigEndian(<hex_code>)

System Monitoring Commands**Query Video Signal Presence**

- ▶ GET•/MEDIA/VIDEO/<port>.SignalPresent

Query Connected Device (or Cable)

- ▶ GET•/MEDIA/VIDEO/<port>.Connected

Query Embedded Audio

- ▶ GET•/MEDIA/VIDEO/<port>.EmbeddedAudioPresent

Hotplug Detect

- ▶ GET•/MEDIA/VIDEO/<port>.Power5vIn

Query Audio Indicators for Microphone Input

- ▶ GET•/MEDIA/AUDIO/I9.<sign_level>

Query Audio Indicators for Advanced Audio Ports

- ▶ GET•/MEDIA/AUDIO/<advanced_port>.<sign_level><channel>

Query the Connection State of the Remote Device

- ▶ GET•/REMOTE/<port>.LinkState

Query Connected Device

- ▶ GET•/REMOTE/<port>.ConnectedDevice

Connected IP Address

- ▶ GET•/REMOTE/<port>.RemotelpAddress

8

Firmware Upgrade

This chapter is meant to help customers perform firmware upgrades on our products by giving a few tips on how to start and by explaining the features of the Lightware Device Updater (LDU) software. To get the latest software and firmware pack can be downloaded from www.lightware.com.

- ▶ [ABOUT THE FIRMWARE PACKAGE \(LFP FILE\)](#)
- ▶ [SHORT INSTRUCTIONS](#)
- ▶ [INSTALL AND UPGRADE](#)
- ▶ [DETAILED INSTRUCTIONS](#)
- ▶ [KEEPING THE CONFIGURATION SETTINGS](#)

The matrix switcher can be upgraded by using the Lightware Device Updater (LDU) software over LAN. The application and the User's manual can be downloaded from www.lightware.com.

8.1. About the Firmware Package (LFP File)

The firmware files are packed in an LFP package. You need only this file to do the upgrade on your device.

- This allows using the same LFP package for different devices.
- The package contains all the necessary components, binary, and other files; You do not have to get further files.
- There is a descriptor file in the package that contains each firmware with version number and a list showing the compatible devices. The descriptor is displayed after loading the LFP file in the LDU.

8.2. Short Instructions

Step 1. Get the firmware pack and the Lightware Device Updater (LDU) application.

Step 2. Install the LDU application.

Step 3. Establish the connection between the computer and the device(s).

Step 4. Start the LDU and follow the instructions shown on the screen.

8.3. Install and Upgrade

Installation for Windows

INFO: The application can be installed under Windows XP or above.

Run the installer. If the User Account Control displays a pop-up message click **Yes**. During the installation you will be prompted to select the type of the installation:

Normal install	Snapshot install
Available for Windows and macOS	Available for Windows
The installer can update only this instance	Cannot be updated
Only one updateable instance can exist for all users	More than one different versions can be installed for all users

Comparison of install types

ATTENTION! Using the Normal install as the default value is highly recommended.

Installation for macOS

INFO: The Windows and the Mac application has the same look and functionality.

Mount the DMG file with double clicking on it and drag the LDU icon over the Applications icon to copy the program into the Applications folder. If you want to copy the LDU into another location just drag the icon over the desired folder.

LDU Upgrade

Step 1. Run the application. In the welcome screen click on the button in the top right corner; the About window will appear. Click on the **Check now** button. The program checks for available updates on the Lightware website and shows the available version.

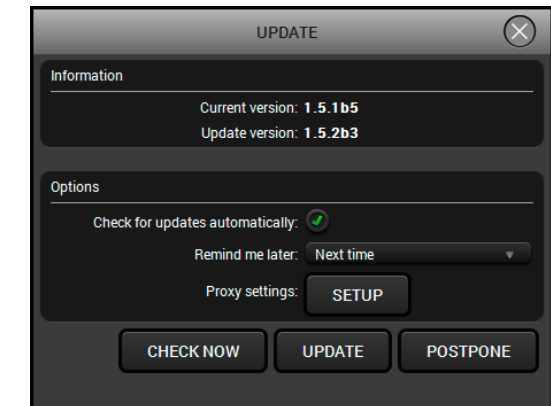

Step 2. Set the desired update settings in the **Options** section.

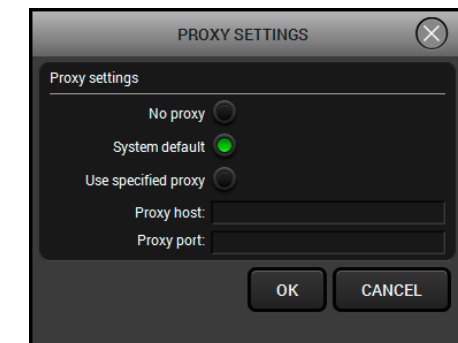

- If you do not want to check for updates automatically, uncheck the **Check for updates automatically** option.
- If you want to postpone the update, a reminder can be set with different delays from the **drop down list**.
- If the proxy settings do not range with the required settings, set the proper values then click the **OK** button.

Step 3. Press the **Update** button to download the new version; the installer will start.

8.4. Detailed Instructions

8.4.1. Establish the Connection between the Computer and the Device

Make sure that the computer and the device are connected via an Ethernet cable and the connection is established between them.

8.4.2. Start the LDU and Follow the Instructions

After launching LDU welcome screen appears:

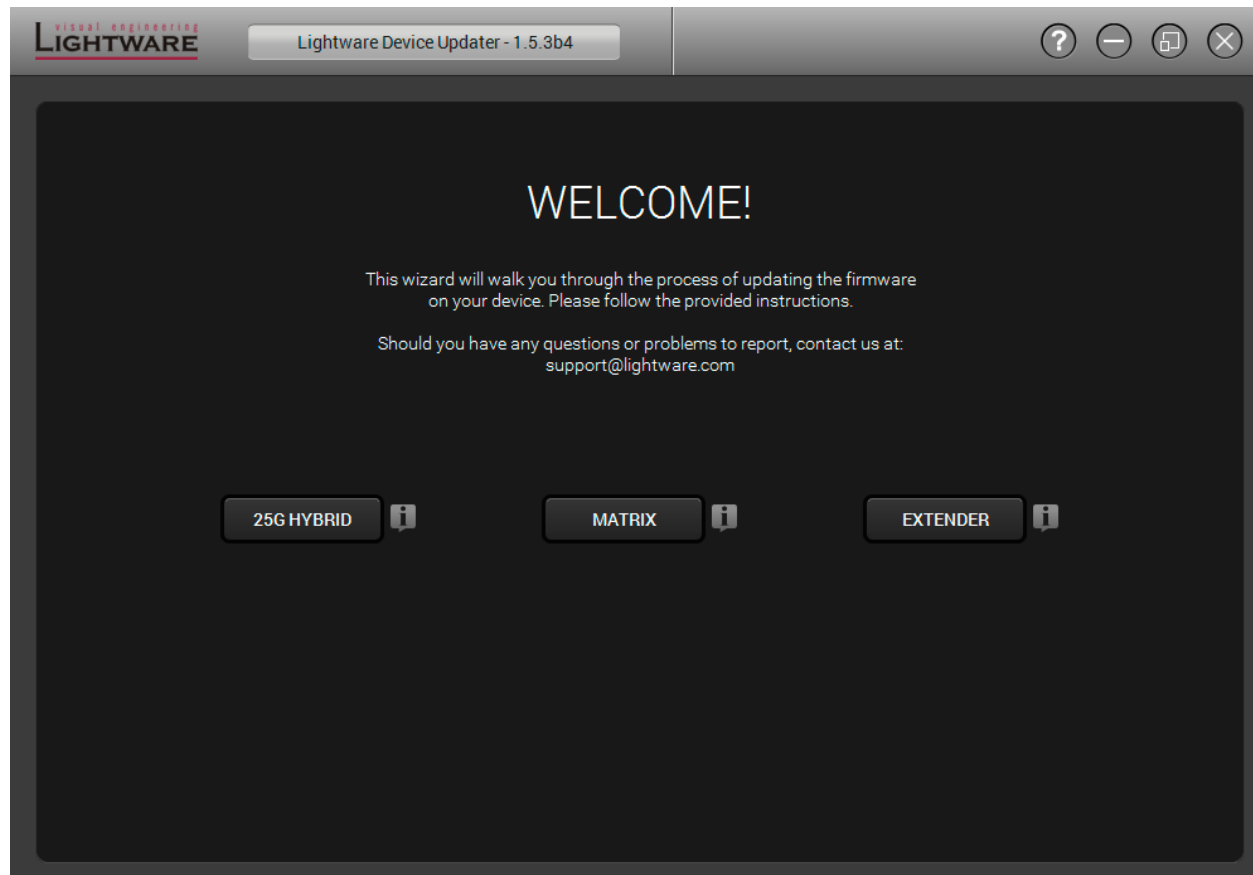

After pressing the **i** button a list will appear showing the supported devices:

Click on the **Matrix** button on the main screen.

Step 1. Select the package.

Click on the Browse button and select the “.lfp” file that will be used for the upgrade.

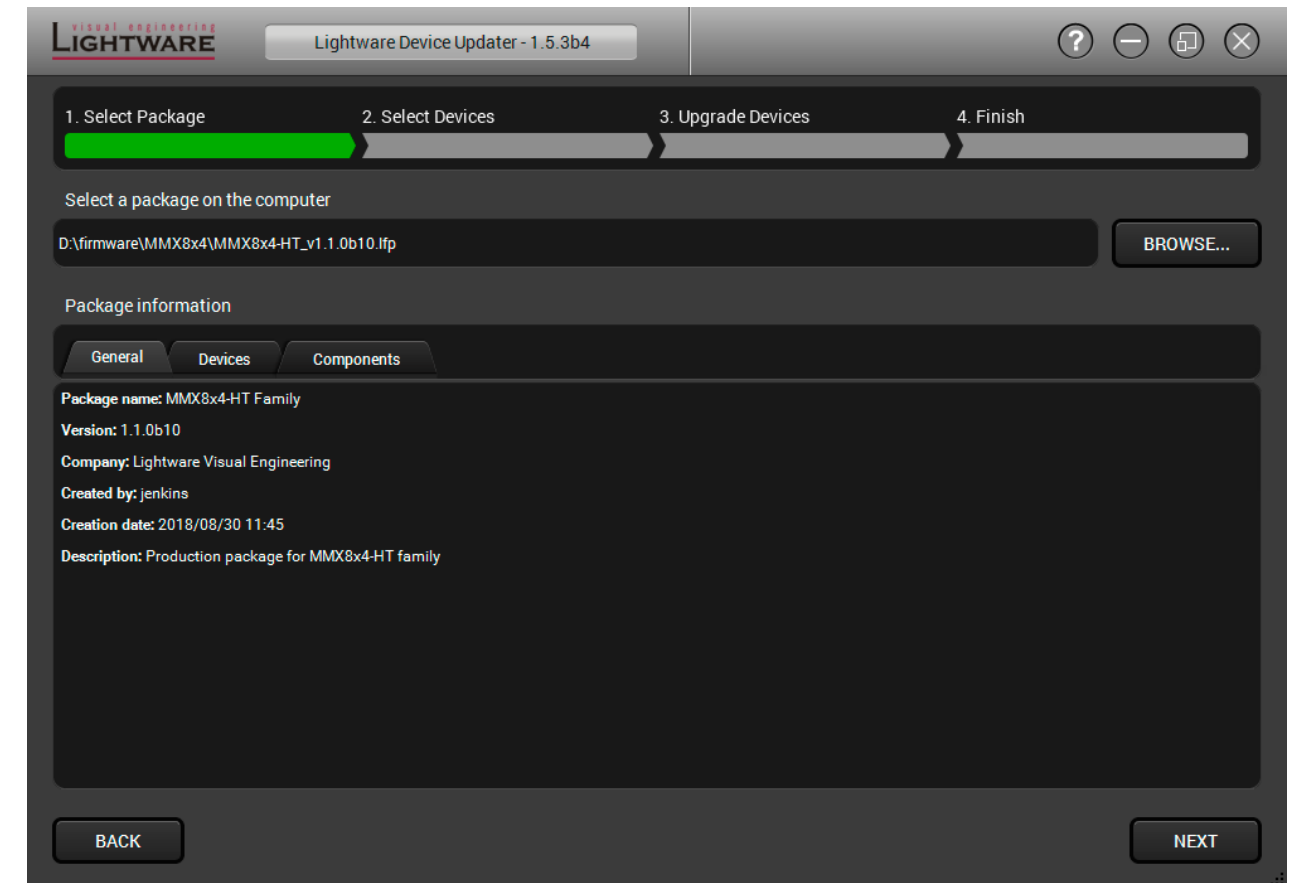

The package information is displayed:

- **General** version info, creation date, short description,
- **Devices** which are compatible with the firmware,
- **Components** in the package with release notes.

TIPS AND TRICKS: Files with “.lfp” extension are associated to LDU during installation. If you double click on the “.lfp” file, the application is launched, the package is loaded automatically and the screen above is shown.

Step 2. Select the device.

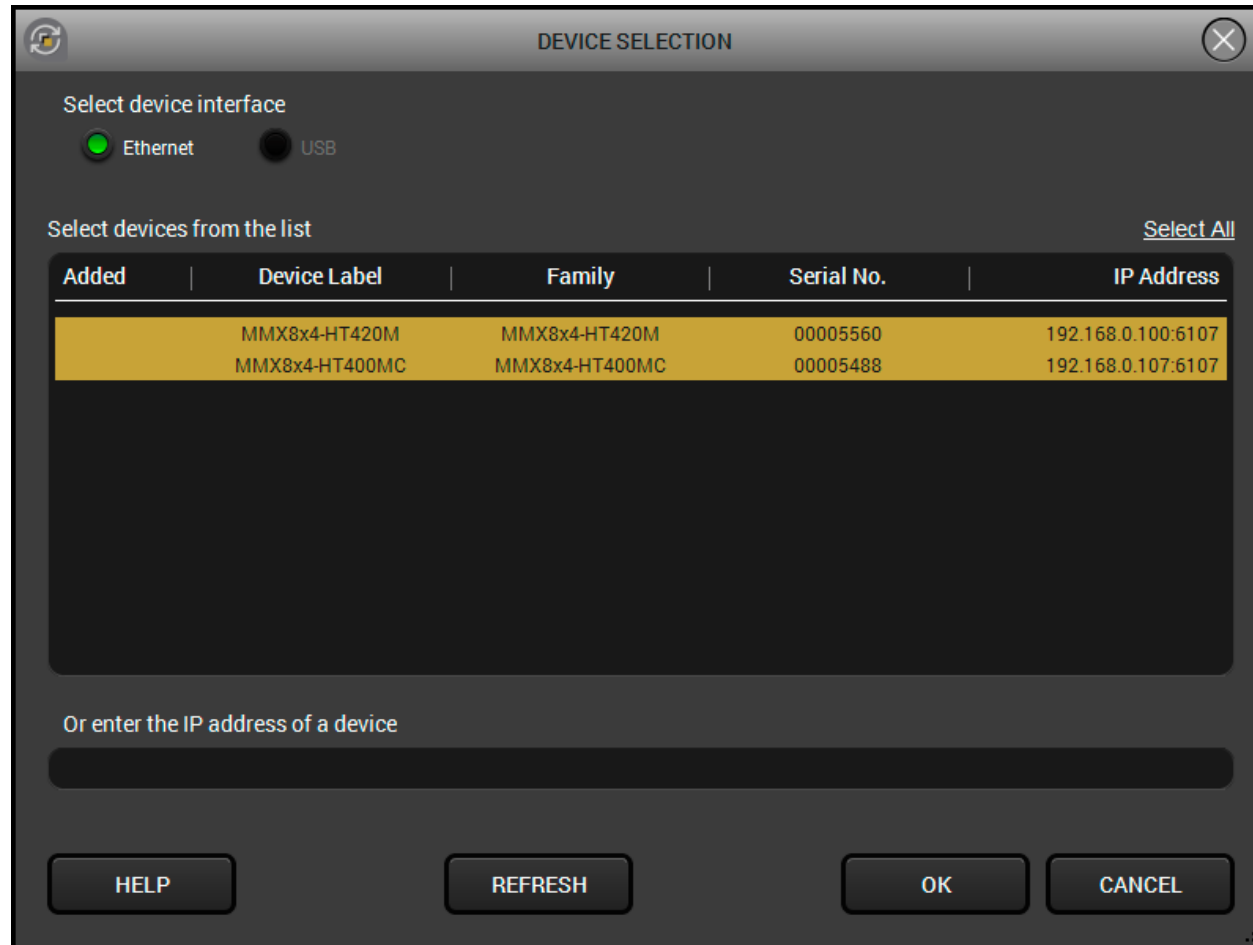

The next step is to select the desired device(s). The available and supported devices are searched for and listed automatically. If the desired device is not listed, update the list by clicking the **Refresh** button. Select the desired device by highlighting them: highlight them with a **yellow cursor**, then click **OK**.

A tick mark can be seen in the **Added** column if the device was added by the user previously.

Firmware Components

The components of the installed and update firmware version for the selected devices are listed on the following screen. (Update version will be uploaded to the device.)

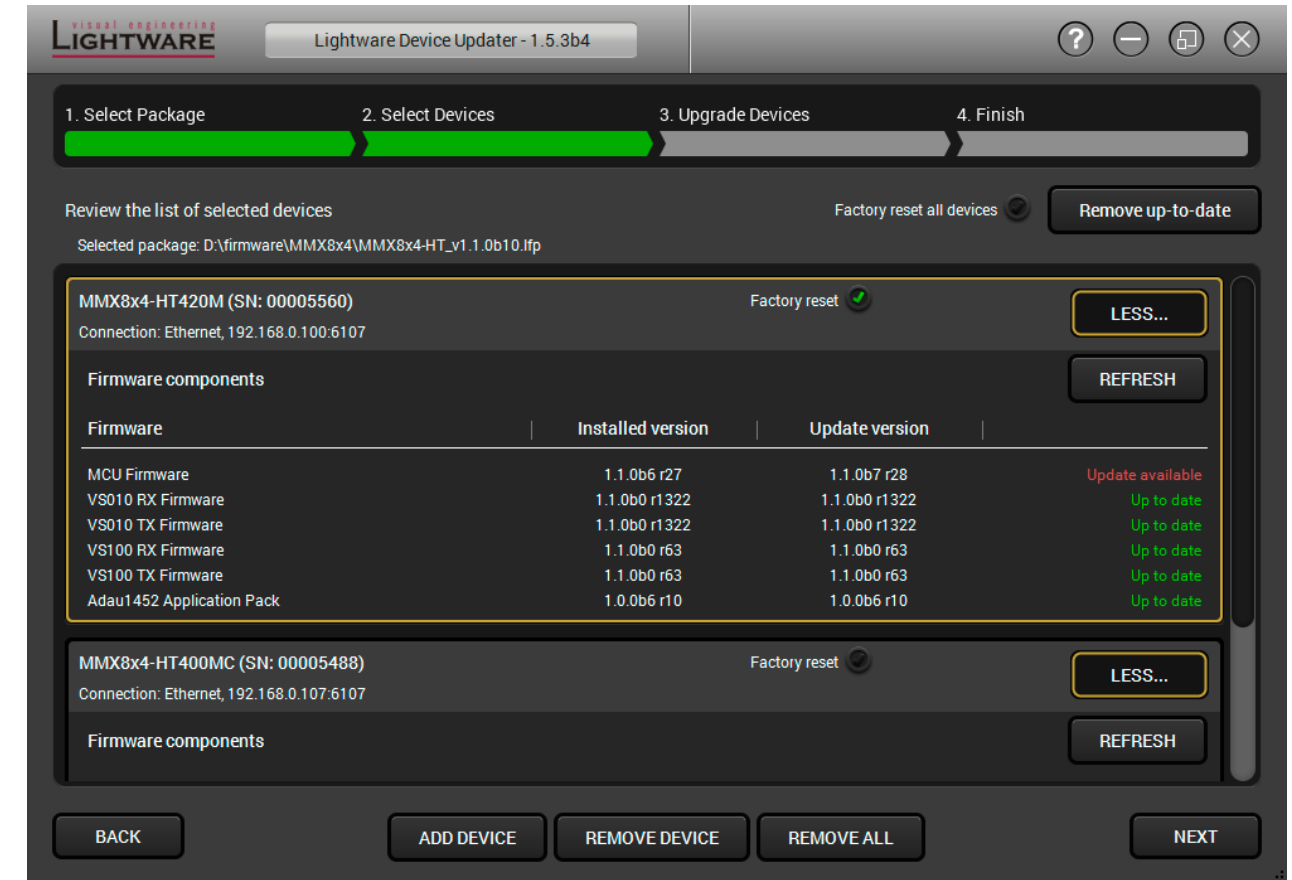

Add a device by clicking on the **Add device** button. The previous screen will be shown; select the desired device(s) and click **OK**.

Remove a device by selecting it (highlight with yellow) and clicking on the **Remove device** button, or by clicking on **Remove all** button to clear the list.

Enabling **Factory reset** will perform factory default values for all settings in the device. Three different status can exist:

- **Enabled by user:** all settings will set to factory default values.
- **Disabled by user:** your settings will be saved and restored after upgrading.
- **Enabled by default and not changeable by user:** firmware upgrade must perform a factory reset to apply all changes coming with the new firmware version.

Click on the **Next** button to continue.

Step 3. Upgrade the device.

A warning window will pop up before upgrading the device:

- Do not unplug the power cable and the LAN cable while the upgrade is in progress. Click **OK** to continue.

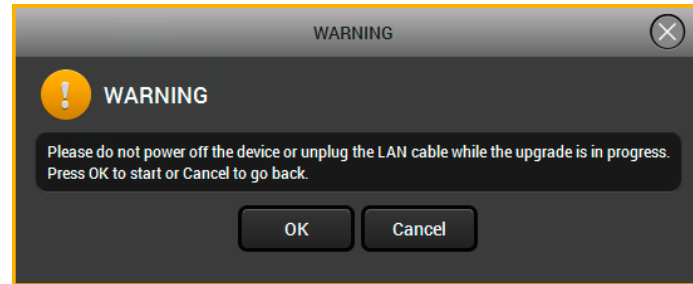

Click on the **Start** button to start the upgrade process.

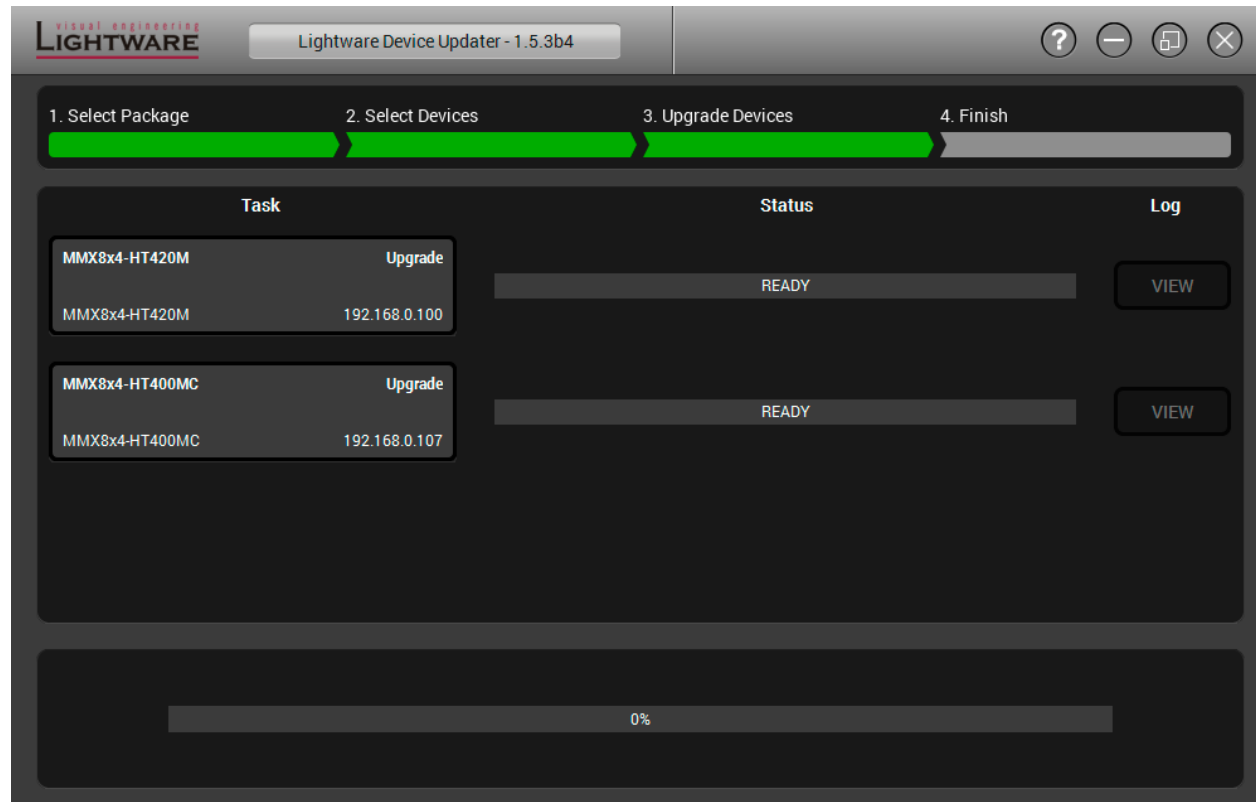

After you confirmed the warnings and clicked on the **Start** button, the upgrade process starts immediately.

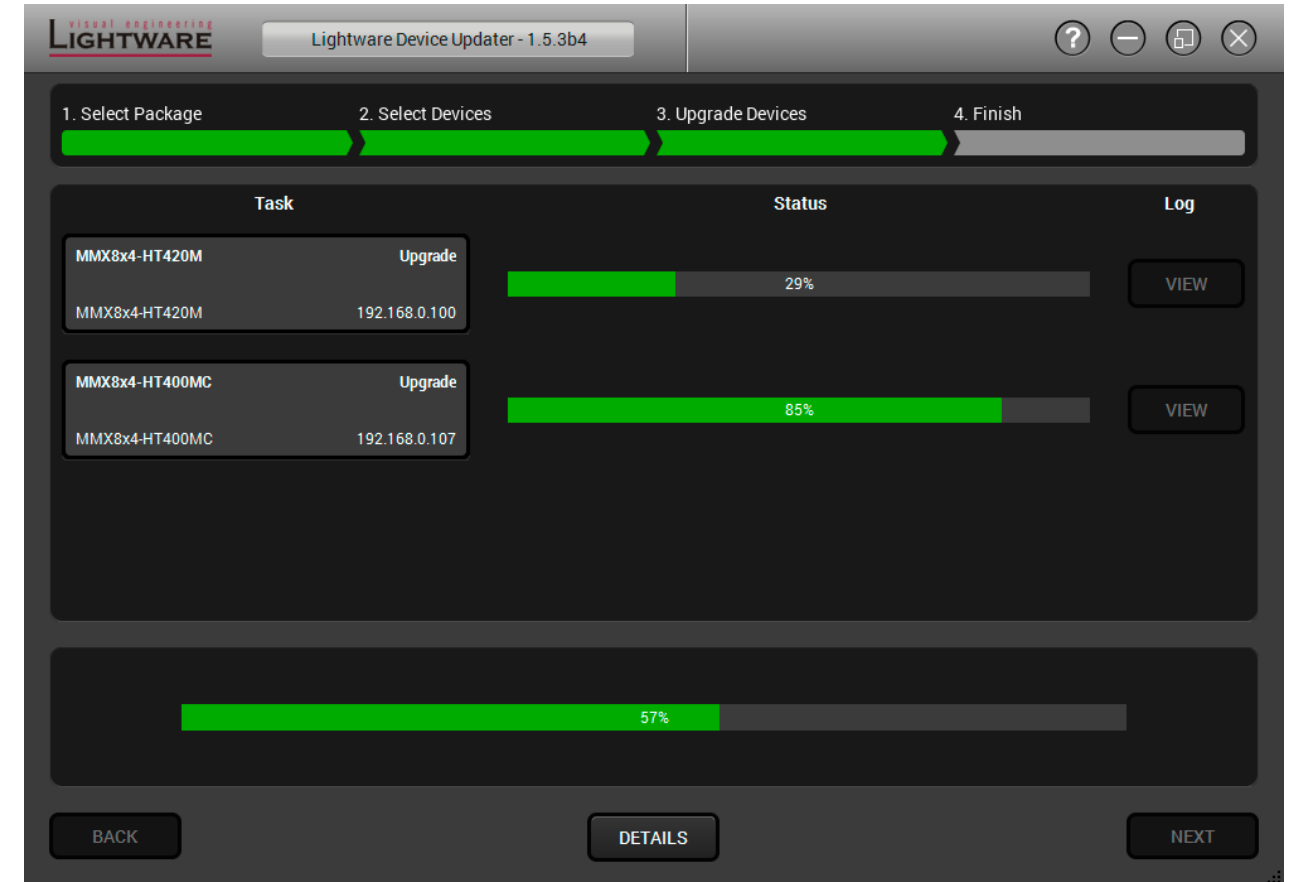

When the upgrade process is done once, a pop-up window appears which means the procedure was successful. Click **OK** to continue.

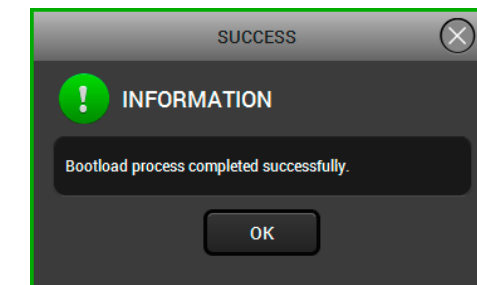

INFO: After the message **Bootload process completed successfully**, the self-upgrade procedure starts. LCD display gives a feedback about the current state of the upgrade process. When the LCD menu appears, it means, that the matrix is ready to use.

Details button opens a new window where the process is logged – see below.

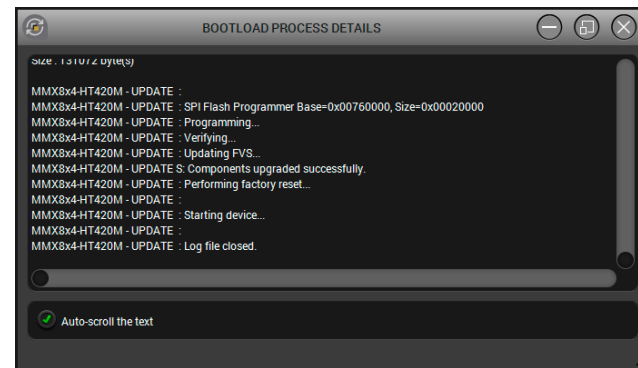

Step 4. Finish.

If the upgrade of a device is finished, the log can be opened by the **View** button on the right. When all the tasks are finished, a window appears. Click **OK** to close and **Next** to display the summary page.

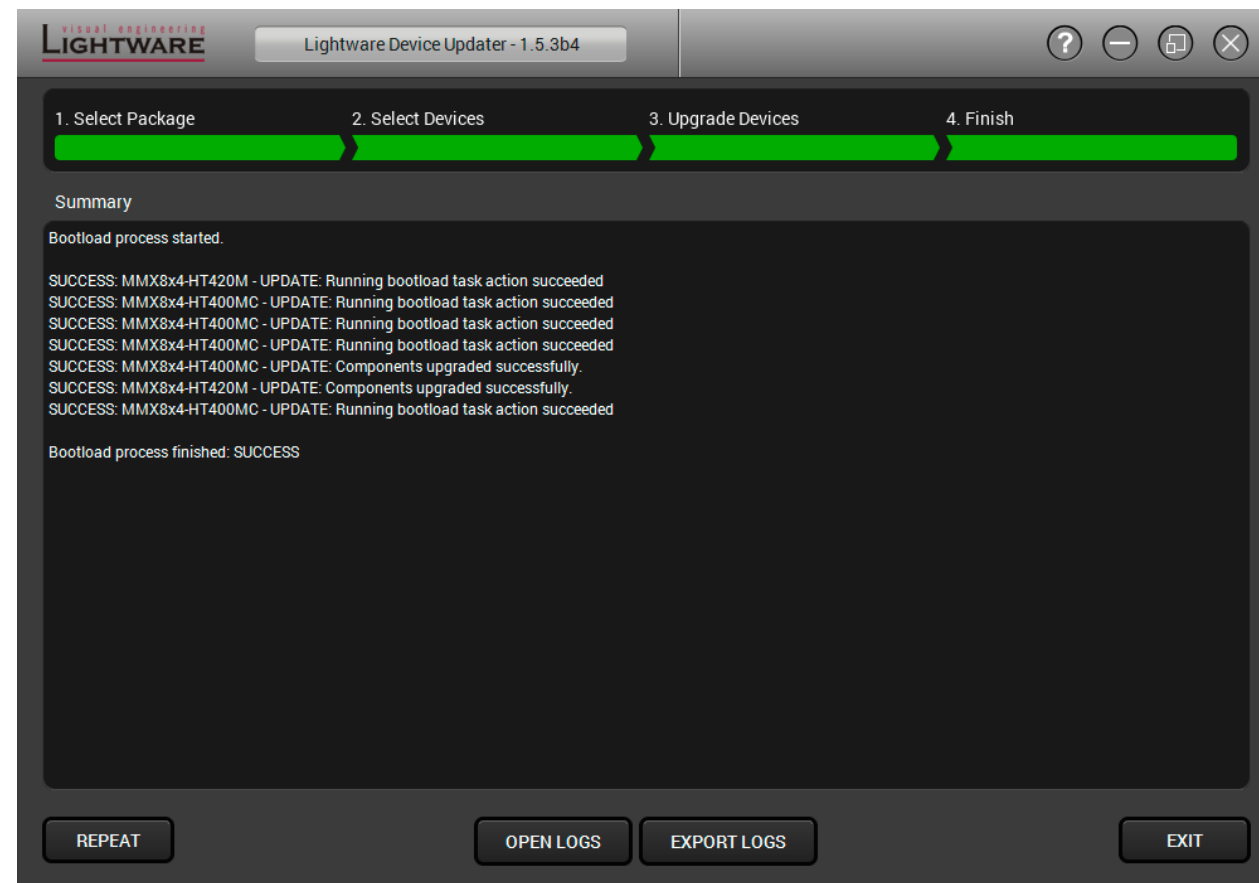

Clicking on the **Repeat** button starts the process again with the selected device(s).

The **Open logs** button opens the temporary folder where the logs can be found.

Export logs by saving the files as a zipped file.

Press **Exit** to close the program.

If the upgrade fails, the progress bar of the device turns to red. Restart the device and repeat the process.

8.5. Keeping the Configuration Settings

User can keep all configuration settings and restore to the device after firmware upgrading or can choose to perform a factory reset – it means all settings will be erased in the device. In case of factory reset you can save the settings of the device and restore it later. For the detailed information about saved data refer to the [Content of Backup File](#) section.

The following flow chart demonstrates how this function works in the background.



Flow chart of firmware upgrade

The details about the procedure: when firmware upgrade starts, the first step is making a backup of the settings of the device. The firmware package checks the backup data and if it is needed, a conversion is applied to avoid incompatibility problems between the firmware versions. If you do not want to keep configuration settings, you can set the **Factory reset** option enabled.

The instruction in the firmware package of the device will inform you about this function availability, reading it is highly recommended in every case.

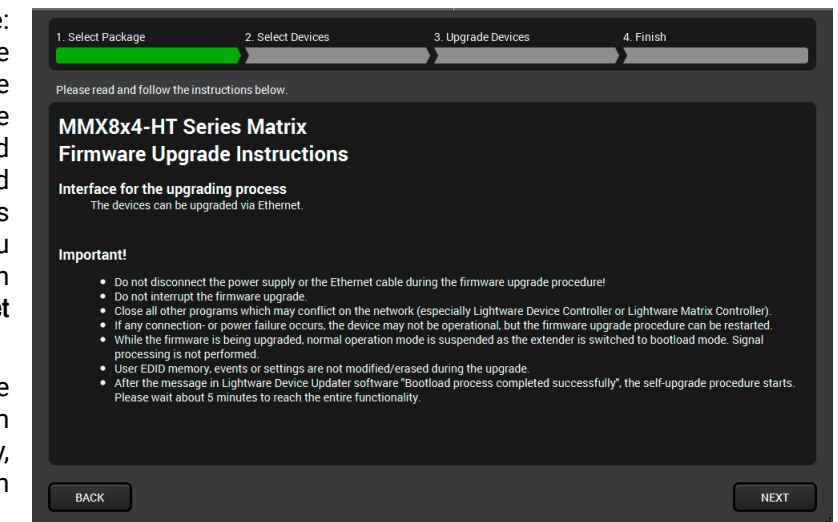

Instructions page in the firmware package

ATTENTION! In specific cases restoring cannot be applied fully and certain settings are not copied back to the device. If a warning message appears, user can get back the original data from the backup. Logs of the upgrade procedure contain all backup data, it can be exported at the end of the upgrade procedure. Details about the procedure of log exporting can be found in the [Detailed Instructions](#) section. In case of any question, please contact support@lightware.com.

ATTENTION! In certain cases, the new firmware version requires setting all parameters to set factory defaults. In this case, the "Factory reset" option is enabled by default and not changeable by the user, see details in the [Firmware Components](#) section.





ATTENTION! The feature is supported from firmware version 1.1.1 together with LDU version 1.3.0.

9



















Troubleshooting













Usually, if the system seems not to transport the signal as expected, the best strategy for troubleshooting is to check signal integrity through the whole signal chain starting from source side and moving forward to receiver end.















Pictogram Legend











-  Section to connections/cabling.
-  Section to front panel operation.
-  Section to LDC software.
-  Section to LW2 protocol commands.
-  Section to LW3 protocol commands.

9.1. Use Case Studies

Symptom	Root cause	Action	Refer to
Video signal			
No picture on the video output	Device(s) not powered properly	Check the matrix and the other devices if they are properly powered; try to unplug and reconnect them.	 4.2
	Cable connection problem	Cables must fit very well, check all the connectors.	 3.3
	No incoming signal	No video signal is present on the HDMI input ports. Check the source device and the HDMI cables.	 3.3.1
	Not the proper video port is the active one	Check the video crosspoint settings.	 4.3.5
			 4.4.3
			 5.4
			 6.3.7
	 7.4.1		
	Not the proper interface is the active one	If the source/display has more connectors, check if the proper interface is selected.	
	Output port is muted	Check the mute state of the ports.	 4.3.2
 5.4.1			
 6.3.4			
 7.5.11 7.5.12			
Display is not able to receive the video format	Check the emulated EDID and select another (e.g. emulate the display's EDID on the input port).	 4.3.3	
		 5.9	
		 7.6	
HDCP is disabled	Enable HDCP on input port(s) of the matrix.	 4.3.2	
		 5.5.1	
		 7.5.9	

Symptom	Root cause	Action	Refer to	
Video signal				
Image is magenta colored	Wrong colorspace was set	The sink expects RGB color spaced signal, but receives YCbCr. Check if the proper signal type was set on the port properties window of the outputs (DVI / HDMI / Auto) or check the emulated EDIDs and select another one or check the colorspace settings on the sink device.	 5.5.1	
			 7.5.20	
Audio signal				
No microphone sound is present on output	Mic input is muted/ signal level/ gain/ volume is too low.	Check the mic channel properties.	 5.7.8	
			 7.9.1	
	Microphone type is condenser.	The condenser microphone needs 48V via the microphone cable which is necessary for normal operation. Turn on the phantom power. WARNING! Application of the phantom power can cause a damage if dynamic or wireless microphone is connected!	 5.7.8	
			 7.8.1.8	
	Wrong wiring of the microphone.	Check the wiring of the microphone cable.	 11.11	
The microphone item is turned off.	Turn on the microphone.			
Not the corresponding audio sounds	Wrong video channel is set on the crosspoint	Check the video crosspoint settings.	 4.3.5	
			 4.4.3	
			 5.4	
			 6.3.7	
			 7.4.1	

Symptom	Root cause	Action	Refer to	
Audio signal				
No audio sounds	Not proper audio mode was set		 5.5.2	
			 7.7.1	
	Audio channel is muted or volume is too low.	Check the audio properties.	 4.3.2	
			 5.7	
			 7.7  7.8	
	Signal type was set to DVI	Check the properties of the output port and set to HDMI or Auto.	 4.3.2	
			 5.5.3	
 7.5.20				
DVI EDID is emulated	Check the EDID and select an HDMI EDID to emulate.	 4.3.3		
		 5.9.2		
			 7.6	
RS-232 signal				
Connected serial device cannot be controlled	Cable connection problem	Check the connectors to fit well; check the wiring of the plugs.	 3.3	
	Serial settings are different	Check the port settings of the matrix and the connected serial device(s). Pay attention to link and/or local ports.	 5.10.1	
 7.9				

Symptom	Root cause	Action	Refer to
Ethernet			
No LAN connection can be established	IP address conflict	Change the IP address to a not reserved one or enable DHCP if DHCP server exists in the network.	 4.3.1
			 5.12.2
			 6.4
			 7.13
	Incorrect IP address is set (direct connect)	Restore the factory default settings (with fix IP).	 4.3.1
			 5.12.2
		 6.2.12	
		 7.3.9	
Event Manager			
Action does not start, although condition is completed.	Too much delay was set.	Check the delay setting on the event Event Editor window. Try it again with zero delay (do not forget verify with Apply button).	 5.11
	The event was not verified/ enabled.	Both Condition and Action (and optionally the Delay) need clicking to verify them. Check if the Event is Enabled on the Events tab.	 5.11

9.2. How to Speed Up the Troubleshooting Process?

Lightware's technical support team is always working hard to provide the fastest support possible. Our team's response time is one of the best in the industry and in the toughest of cases we can directly consult with the hardware or software engineer who designed the product to get the information from the most reliable source.

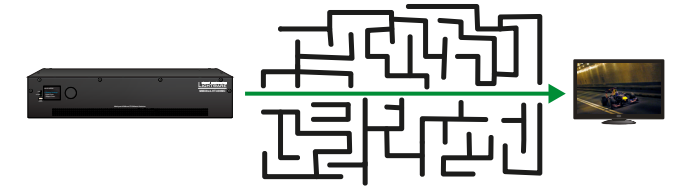

However, the troubleshooting process can be even faster... with your help.

There are certain pieces of information that push us in the right direction to finding the root cause of the problem. If we receive most of this information in the first e-mail or it is gathered at the time when you call us, then there is a pretty high chance that we will be able to respond with the final solution right away.

This information is the following:

- Schematic (a pdf version is preferred, but a hand drawing is sufficient).
- Serial number(s) of the device(s) (it is either printed somewhere on the box or you can query it in the Device Controller software or on the built-in website).
- Firmware versions of the devices (please note that there may be multiple CPUs or controllers in the device and we need to know all of their firmware versions, a screenshot is the best option).
- Cable lengths and types (in our experience, it's usually the cable).
- Patch panels, gender changers or anything else in the signal path that can affect the transmission.
- Signal type (resolution, refresh rate, color space, deep color).
- Emulated EDID(s) (please save them as file and send them to us).
- Actions to take in order to re-create the problem (if we cannot reproduce the problem, it is hard for us to find the cause).
- Photo or video about the problem ('image noise' can mean many different things, it's better if we see it too).
- Error logs from the Device Controller software.
- In the case of Event Manager issue the event file and/or backup file from the Device Controller software.

The more of the above information you can give us the better. Please send these information to the Lightware Support Team (support@lightware.com) to speed up the troubleshooting process.

10

Technologies

The following sections contain descriptions and useful technical information how the devices work in the background. The content is based on experiences and cases we met in the practice. These sections help to understand features and technical standards like the followings:

- ▶ EDID MANAGEMENT
- ▶ HDCP MANAGEMENT
- ▶ PIXEL ACCURATE RECLOCKING

10.1. EDID Management

10.1.1. Understanding the EDID

The Extended Display Identification Data (EDID) is the passport of display devices (monitors, TV sets, projectors). It contains information about the capabilities of the display, such as supported resolutions, refresh rates (these are called Detailed Timings), the type and manufacturer of the display device, etc.

After connecting a source to a display (DVI, HDMI, DP), the source reads out the EDID to determine the resolution and refresh rate of the image to be transmitted.

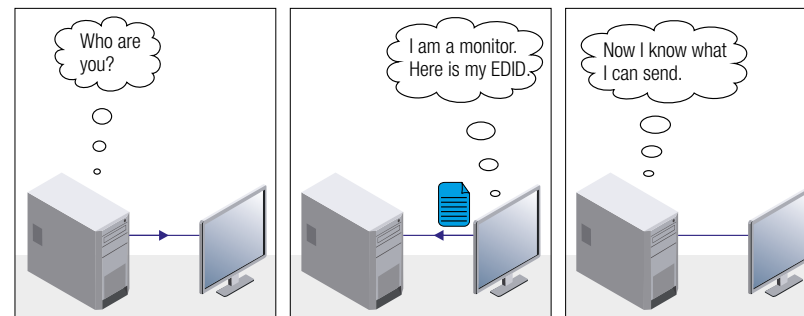

EDID Communication

Most DVI computer displays have 128-byte long EDID structure. However, Digital Televisions and HDMI capable displays may have another 128 bytes, which is called E-EDID and defined by CEA (Consumer Electronics Association). This extension contains information about additional Detailed Timings, audio capabilities, speaker allocation and HDMI capabilities. It is important to know that all HDMI capable devices must have CEA extension, but not all devices with CEA extension are HDMI capable.

Common Problems Related to EDID

Problem: "My system consists of the following: a computer, a Lightware device, a WUXGA (1920x1200) LCD monitor, and an SXGA (1280x1024) projector. I would like to see the same image on the monitor and the projector. What EDID should I choose on the Lightware device?"

Solution: If you want to see the image on both displays, you need to select the resolution of the smaller display (in this case SXGA), otherwise the smaller display may not show the higher resolution image.

Problem: "I have changed to a different EDID on an input port of the Lightware device to have a different resolution but nothing happens."

Solution: Some graphics cards and video sources read out the EDID only after power-up and later they do not sense that EDID has been changed. You need to restart your source to make it read out the EDID again.

10.1.2. Advanced EDID Management

Each DVI sink (e.g. monitors, projectors, plasma displays, etc...) must support the EDID data structure. Source BIOS and operating systems are likely to query the sink using DDC2B protocol to determine what pixel formats and interface are supported. DVI standard uses EDID data structure to identify the monitor type and capabilities. Most DVI sources (VGA cards, set top boxes, etc.) will output DVI signal after accepting the connected sink's EDID information. In the case of EDID readout failure or missing EDID, the source will not output DVI video signal.

Lightware devices provide the Advanced EDID Management function that helps system integration. The built-in EDID Router can store and emulate factory pre-programmed- and User programmable EDIDs. The EDID of the attached monitors or projectors for each output are stored in a non-volatile memory. This way the EDID of a monitor is available when the monitor is unplugged or switched off.

Any EDID can be emulated on any input. An emulated EDID can be copied from the EDID router's memory (static EDID emulation), or from the last attached monitor's memory (dynamic EDID emulation). For example, the Lightware device can be set up to emulate a sink device, which is connected to one of the outputs. In this case, the EDID automatically changes, if the monitor is replaced with another display device (as long as it has a valid EDID).

EDID is independently programmable for all inputs without affecting each other. All inputs have their own EDID circuit.

INFO: The user is not required to disconnect the video cable to change an EDID as opposed to other manufacturer's products. EDID can be changed even if a source is connected to the input and powered ON.

INFO: When EDID has been changed, the router toggles the HOTPLUG signal for 2 seconds. Some sources do not sense this signal. In such cases, the source device must be restarted or powered OFF and ON again.

10.2. HDCP Management

Lightware Visual Engineering is a legal HDCP adopter. Several functions have been developed which helps to solve HDCP related problems. Complex AV systems often have both HDCP and non-HDCP components. The matrix allows transmitting HDCP encrypted and unencrypted signals. The devices will be still HDCP compliant as they will never output an encrypted signal to a non-HDCP compliant display device. If an encrypted signal is switched to a non-compliant output, a red screen alert or muted screen will appear.

10.2.1. Protected and Unprotected Content

Many video sources send HDCP protected signal if they detect that the sink is HDCP capable – even if the content is not copyrighted. This can cause trouble if an HDCP capable device is connected between the source and the display. In this case, the content cannot be viewed on non-HDCP capable displays and interfaces like event controllers. Rental and staging technicians often complain about certain laptops, which are always sending HDCP encrypted signals if the receiver device (display, matrix router, etc.) reports HDCP compliancy. However, HDCP encryption is not required all the time e.g. computer desktop image, certain laptops still do that.

To avoid unnecessary HDCP encryption, Lightware introduced the HDCP enabling/disabling function: the HDCP capability can be disabled in the Lightware device. If HDCP is disabled, the connected source will detect that the sink is not HDCP capable, and turn off authentication.

10.2.2. Disable Unnecessary Encryption

HDCP Compliant Sink



All the devices are HDCP-compliant, no manual setting is required, both protected and unprotected contents are transmitted and displayed on the sink.

Not HDCP-compliant Sink 1.



Not-HDCP compliant sink is connected to the matrix. Some sources (e.g. computers) always send HDCP encrypted signals if the receiver device reports HDCP compliancy, however, HDCP encryption is not required all the time (e.g. computer desktop image). If HDCP is enabled in the matrix, the image will not be displayed on the sink.

Setting the HDCP parameter to Auto on the output port and disable HDCP on the input port, the transmitted signal will not be encrypted if the content is not protected. Thus, non-HDCP compliant sinks will display non-encrypted signal.

Not HDCP-compliant Sink 2.



The layout is the same as in the previous case: non-HDCP compliant display device is connected to the matrix but the source would send protected content with encryption. If HDCP is enabled on the input port of the matrix, the source will send encrypted signal. The sink is not HDCP compliant, thus, it will not display the video signal (but blank/red/muted/etc. screen). If HDCP is disabled on the input port of the matrix, the source will not send the signal. The solution is to replace the display device to an HDCP-capable one.

10.3. Pixel Accurate Reclocking

Signal reclocking is an essential important procedure in digital signal transmission. After passing the reclocking circuit, the signal becomes stable, jitter-free, and can be transmitted over more equipment like processors, or event controllers. Without reclocking, sparkles, noise, and jaggies appear on the image.

Lightware's sophisticated Pixel Accurate Reclocking technology fixes more problems than general TMDS reclocking. It removes not only intra-pair skew but inter-pair skew as well. The Pixel Accurate Reclocking circuit eliminates the following errors:

Intra-pair skew

Skew between the + and - wires within a differential wire pair (e.g. Data2- and Data2+). It's caused by different wire lengths or slightly different wire construction (impedance mismatch) in DVI cable. It results in jitter.

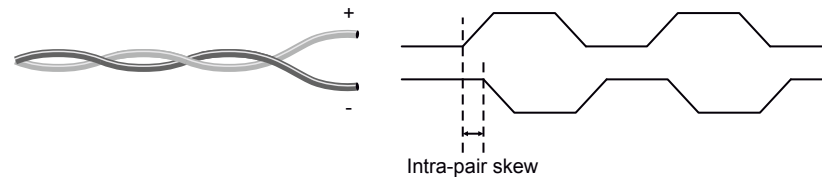

Inter-pair skew

Skew between two differential wire pairs in a cable. It is caused by different wire pair lengths or different number of twists in the DVI cable. Too much inter-pair skew results color shift in the picture or sync loss.

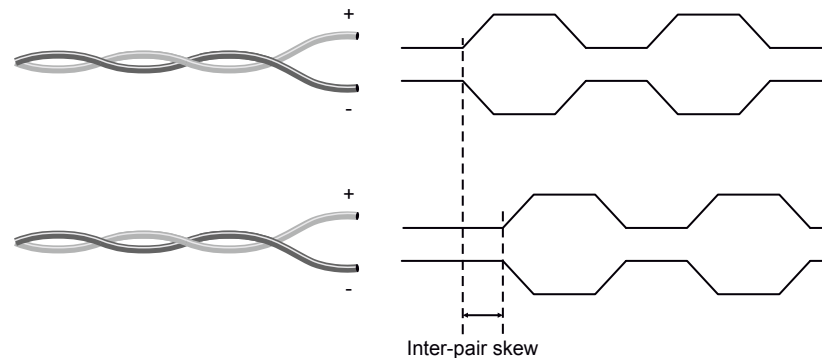

Jitter

Signal instability in the time domain. The time difference between two signal transitions should be a fixed value, but noise and other effects cause variations.

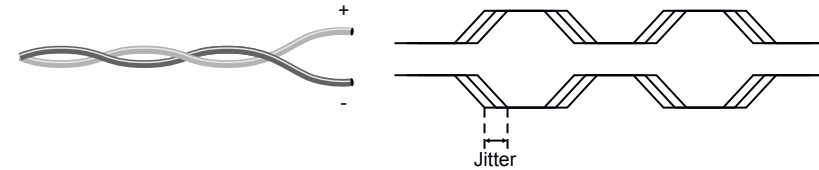

Noise

Electromagnetic interference between other electronic devices such as mobile phones, motors, etc. and the DVI cable are coupled onto the signal. Too much noise results in increased jitter.

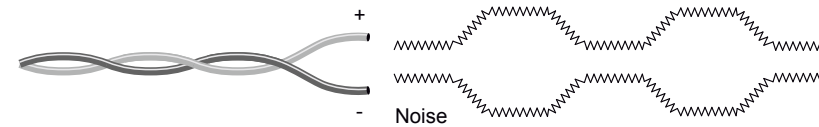

11

Appendix

- ▶ [SPECIFICATION](#)
- ▶ [MECHANICAL DRAWINGS](#)
- ▶ [MAXIMUM EXTENSION DISTANCES](#)
- ▶ [FACTORY DEFAULT SETTINGS](#)
- ▶ [CONTENT OF BACKUP FILE](#)
- ▶ [FLOWCHART OF AUTOSELECT MODES](#)
- ▶ [PORT NUMBERING](#)
- ▶ [CONDITIONS IN THE WIZARD TAB OF THE EVENT MANAGER](#)
- ▶ [ACTIONS IN THE WIZARD TAB OF THE EVENT MANAGER](#)
- ▶ [FACTORY EDID LIST](#)
- ▶ [AUDIO CABLE WIRING GUIDE](#)

11.1. Specification

General

Compliance	CE
EMI/EMC	IEC/EN 55035:2017, IEC/EN 55032:2015
RoHS compliance	Yes
Warranty	3 years
Cooling.....	by cooling fans, air flows from front to rear
Operating temperature	0 to +50°C (+32 to +122°F)
Operating humidity	10% to 90%, non-condensing

Power

Power source	100-240 V AC; 50~60 Hz
Power consumption - MMX8x4-HT400MC	44,6W (max.)
Power consumption - MMX8x4-HT420M.....	99,2 W (max.)
Power consumption - MMX8x8-HDMI-4K-A.....	34,6W (max.)
Power over TPS.....	DC 48V (IEEE 802.3af)

Enclosure

Front panel buttons - MMX8x4-HT400MC, MMX8x4-HT420M.....	No
Front panel buttons - MMX8x8-HDMI-4K-A.....	Yes
Display	LCD
Rack mountable	Yes, 2U High (rack ears supplied)
Material.....	1 mm steel
Dimensions in mm.....	442 (482*) W x 87.8 H x 300 D
Dimensions in inch	17.4 (18.9*) W x 3.45 H x 11.8 D
Weight - MMX8x4-HT400MC	4.8 kg
Weight - MMX8x4-HT420M.....	5.0 kg
Weight - MMX8x8-HDMI-4K-A	4.5 kg

* with rack-mounting ears

Video I/O ports

Standard	DVI 1.0, HDMI 1.4
Max. video resolutions	3840x2160@30Hz RGB 4:4:4
.....	3840x2160@60Hz YCbCr 4:2:0
.....	1920x1080@120 Hz, 24 bit RGB 4:4:4

Embedded audio formats	2 channel PCM Stereo, 8 channel PCM
.....	Dolby TrueHD, DTS-HD Master Audio 7.1
HDCP compliant.....	Yes, HDCP 1.4
Reclocking.....	Pixel Accurate Reclocking

HDMI Input/Output Ports

HDMI port connector type.....	19-pole HDMI Type A receptacle
-------------------------------	--------------------------------

In MMX8x4-HT400MC, MMX8x4-HT420M models

TPS Ports Input/Output Ports

TPS port connector type.....	RJ45 connector
Compliance	HDBaseT
Transferred signals (TPS)	Video, Audio, RS-232, Ethernet*
*Only in MMX8x4-HT420M model	

Microphone input port

Input signal.....	Balanced audio
Gain.....	-12dB +55dB
Volume.....	-80dB +10dB
Phantom power.....	48V

Analog audio I/O ports

Audio signal.....	Balanced or unbalanced audio
Gain*	0dB +24dB
Volume.....	-48.18dB +0dB
*Only for inputs.	

Advanced analog audio input port

Input signal.....	Balanced or unbalanced audio
Gain.....	-12dB +21dB
Volume.....	-80dB +10dB

Advanced analog audio output port

Output signal.....	Balanced audio
Volume.....	-80dB +10dB

Control Ethernet

Connector type..... Locking RJ45
 Ethernet data rate 10/100Base-T, full duplex with autodetect
 Power over Ethernet (PoE)Not supported

RS-232

Connector type..... 3-pole Phoenix connector
 Available Baud ratesbetween 4800 and 115200 baud
 Available Data bits 8 or 9
 Available Parity..... None / Odd / Even
 Available Stop bits1 / 1.5 / 2
 Output voltage: Low level 3 - 15V
 Output voltage: High level-15V - 3V

TTL Serial

Connector type..... 2-pole Phoenix connector
 Logic low level..... 0 - 0.25V
 Logic high level 4.75 - 5.0V

Infra

Connector type..... 2-pole Phoenix connector
 Connector type..... 3.5mm TRS

GPIO

Connector type..... 8-pole Phoenix connector
 Number of configurable pins 6
 Port direction..... Input or output
 Input voltage: Low level0 - 0,8 V
 Input voltage: High level 2 - 5 V
 Output voltage: Low level0 - 0,5 V
 Output voltage: High level 4.5 - 5 V
 Max. current: Low level..... 30 mA
 Max. current: High level..... 18 mA
 Total available current 180 mA

Relay

Connector type..... 8-pole Phoenix connector
 Number of relays.....4
 Type.....Normally open contacts
 Maximum ratings..... 30 V, 1 A, AC/DC
 Default connection state..... Open

11.2. Mechanical Drawings

MMX8x4-HT400MC, MMX8x4-HT420M and MMX8x8-HDMI-4K-A matrix switchers have the same size.

Dimensions are in mm.

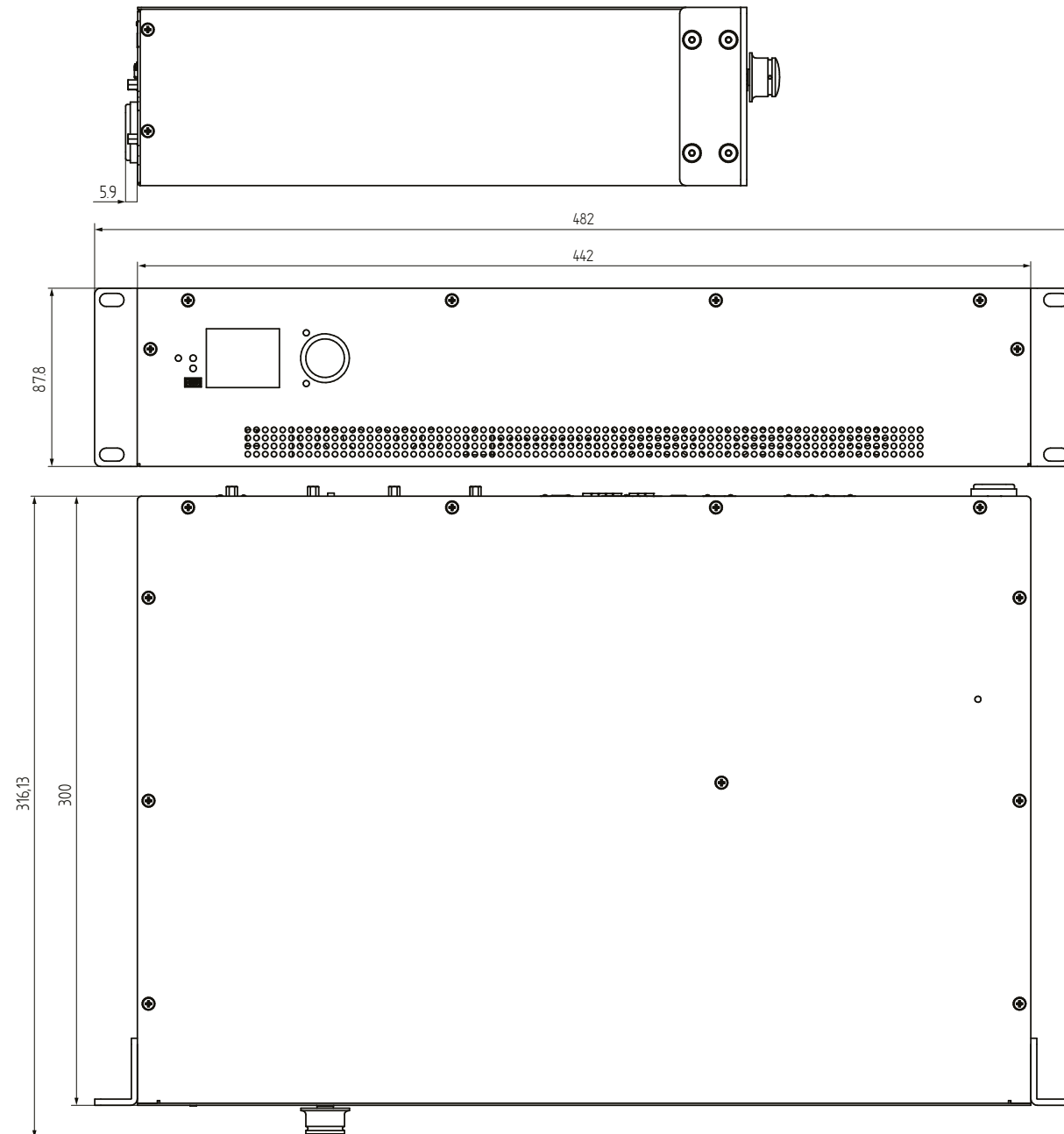

11.3. Maximum Extension Distances

To specify the accurate extension distances, please also check the documentation of the connected HDBaseT-compatible device.

MMX8x4-HT400MC

Resolution	Pixel clock rate	Cable lengths (or 'C' Corporate models)	
		CAT5e AWG24	CAT7 AWG26 and CAT7 AWG23
1024x768@60Hz	65 MHz	60m	80m
1280x720p@60Hz	73.8 MHz	60m	80m
1920x1080p@60Hz / 24bpp	148.5 MHz	60m	80m
1920x1200@60Hz	152.9 MHz	60m	80m
1600x1200@60Hz	162 MHz	60m	80m
1920x1080@60Hz / 36bpp	223.6 MHz	60m	80m
3840x2160@30Hz UHD	297 MHz	40m	40m
4096x2160@30Hz 4K	297 MHz	40m	40m

MMX8x4-HT420M

Resolution	Pixel clock rate	Cable lengths (Auto / Longreach TPS mode)		
		CAT5e AWG24	CAT7 AWG26**	CAT7 AWG23
1024x768@60Hz	65 MHz	100 m / 130 m*	90 m / 120 m*	120 m / 170 m*
1280x720p@60Hz	73.8 MHz	100 m / 130 m*	90 m / 120 m*	120 m / 170 m*
1920x1080p@60Hz / 24bpp	148.5 MHz	100 m / 130 m*	90 m / 120 m*	120 m / 170 m*
1920x1200@60Hz	152.9 MHz	100 m / NA	90 m / NA	120 m / NA
1600x1200@60Hz	162 MHz	100 m / NA	90 m / NA	120 m / NA
1920x1080@60Hz / 36bpp	223.6 MHz	70 m / NA	70 m / NA	100 m / NA
3840x2160@30Hz UHD	297 MHz	70 m / NA	70 m / NA	100 m / NA
4096x2160@30Hz 4K	297 MHz	70 m / NA	70 m / NA	100 m / NA

* With Long reach operation mode which supports pixel clock frequencies up to 148.5 MHz.

** When remote powering is used with AWG26 cables, distances are 20% shorter.

11.4. Factory Default Settings

Network Settings	
Parameter	Setting/Value
IP address	192.168.0.100
Subnet mask	255.255.255.0
Static gateway	192.168.0.1
LW2 Port number	10001
LW3 Port number	6107
HTTP Port number	80
DHCP	disabled
Video Port Settings	
Parameter	Setting/Value
HDCP – on input ports	Enabled
HDCP – on output ports	Auto
Output signal type	Auto
Power 5V mode	Auto
No sync screen mode/ color/ resolution	Off/ Bar/ 480p
Crosspoint state	I1 on all outputs
Audio source ¹	HDMI audio passthrough
Autoselect	Disabled
Emulated EDID	F47 - Factory (1920x1080@60Hz HDMI)
PoE feature ³	Enabled
TPS mode (on input ports) ²	Auto
TPS mode (on output ports) ³	Auto
Analog Audio Port Settings ²	
Parameter	Setting/Value
MIC input levels	Volume (dB): 0.00 / Panorama: 0 / Gain (dB): 0.00
Analog audio input levels	Volume (dB): 0.00 / Balance: 0 / Gain (dB): 0.00
Analog audio output levels	Volume (dB): 0.00 / Balance: 0

Advanced Audio Settings ²	
Microphone input settings (I9)	
Parameter	Setting/Value
Mute	false
Volume	0.00
Panorama	0
Phantom Power	false
Invert Phase	false
HPF / LPF	false
EQ HIGH/HMID /LMID /LOW gain	0.00
Feedback Cancel	false
Input Gain	0.00
Port text	MICIN
Advanced analog audio input settings (I10)	
Parameter	Setting/Value
Mute	false
Volume	0.00
Balance	0
Invert Phase	false
HPF / LPF	false
EQ HIGH/HMID /LMID /LOW gain	0.00
Ducker	false
Input Gain	0.00
Port text	LINEIN
Embedded or advanced audio input (I11)	
Parameter	Setting/Value
Mute	false
Volume	0.00
Balance	0
Invert Phase	false
HPF / LPF	false
EQ HIGH/HMID /LMID /LOW gain	0.00
Ducker	false
Input Gain	0.00
Audio source	I1 original audio content

Advanced audio output (O6)	
Parameter	Setting/Value
Mute	false
Volume	0.00
Balance	0
Invert Phase	false
HPF / LPF	false
EQ HIGH/HMID /LMID /LOW gain	0.00
Delay, Delay time	false, 0
Mono mix	false
Port text	LINEOUT
Serial Settings	
Parameter	Setting/Value
Control protocol	LW2
Port number	8001, 8002, 8003, 8004
Baud rate / Databits / Parity / Stopbits	57600 / 8 / No / 1
Operation mode of RS-232 ports	CI (Command Injection)
Operation mode of IR/TTL ports	CI (Command Injection)
Operation mode of TPS ports	Control
IR Settings	
Parameter	Setting/Value
Operation mode	CI (Command Injection)
Port number	9001, 9002, 9003, 9004
Relay Settings ³	
Parameter	Setting/Value
Connection state	Open
GPIO Settings ³	
Parameter	Setting/Value
Direction	Input
Input level	High

¹ In MMX8x4-HT420M and MMX8x8-HDMI-4K-A models.

² In MMX8x4-HT400MC and MMX8x4-HT420M models.

³ In MMX8x4-HT420M model.

11.5. Content of Backup File

The backup file contains numerous settings and parameters saved from the device. When the file is uploaded to a device, the followings will be overwritten:

Network settings

- DHCP status (enable / disable)
- Static IP address, Network mask, Gateway address

Video ports settings

- Port name
- Port status (Lock/Unlock/Mute/Unmute, Autoselect settings)
- Crosspoint state
- HDCP status (enable / disable), Test pattern settings, Signal type, HDCP mode, PWR5V mode
- TPS mode²
- PoE (enable / disable)³

Audio settings (for I/O audio ports)¹

- Audio mode
- Mute, Volume, Balance, Gain

Microphone and advanced audio settings²

- Mute, Volume, Balance, Gain, Panorama/Balance, Invert phase, HPF, LPF, EQ
- Phantom Power, Feedback (only for the microphone)
- Ducker (only for the advanced audio input channel)
- Delay, mono (only for the advanced audio output channel)

RS-232 settings

- Port name
- Rs232Mode (Command injection / Control / Disconnect)
- Command injection status (enable / disable)
- Command injection port number
- Baud rate, Data bits, Parity, Stopbits, Control protocol

IR settings

- Port name
- Port status (enable / disable)
- Command injection status (enable / disable)
- Command injection port number

Ethernet settings

- Port name, Port status (enable / disable)

GPIO settings³

- Port name, Direction, Input level

Relay settings³

- Connection state

Other settings

- User EDID data
- Emulated EDID list
- Event manager: All Events' settings (1-100)
- All Presets' settings (1-6)
- Device label
- Rotary direction, Display brightness, Control lock

¹ In MMX8x4-HT420M and MMX8x8-HDMI-4K-A models.

² In MMX8x4-HT400MC and MMX8x4-HT420M models.

³ In MMX8x4-HT420M model.

11.6. Flowchart of Autoselect Modes

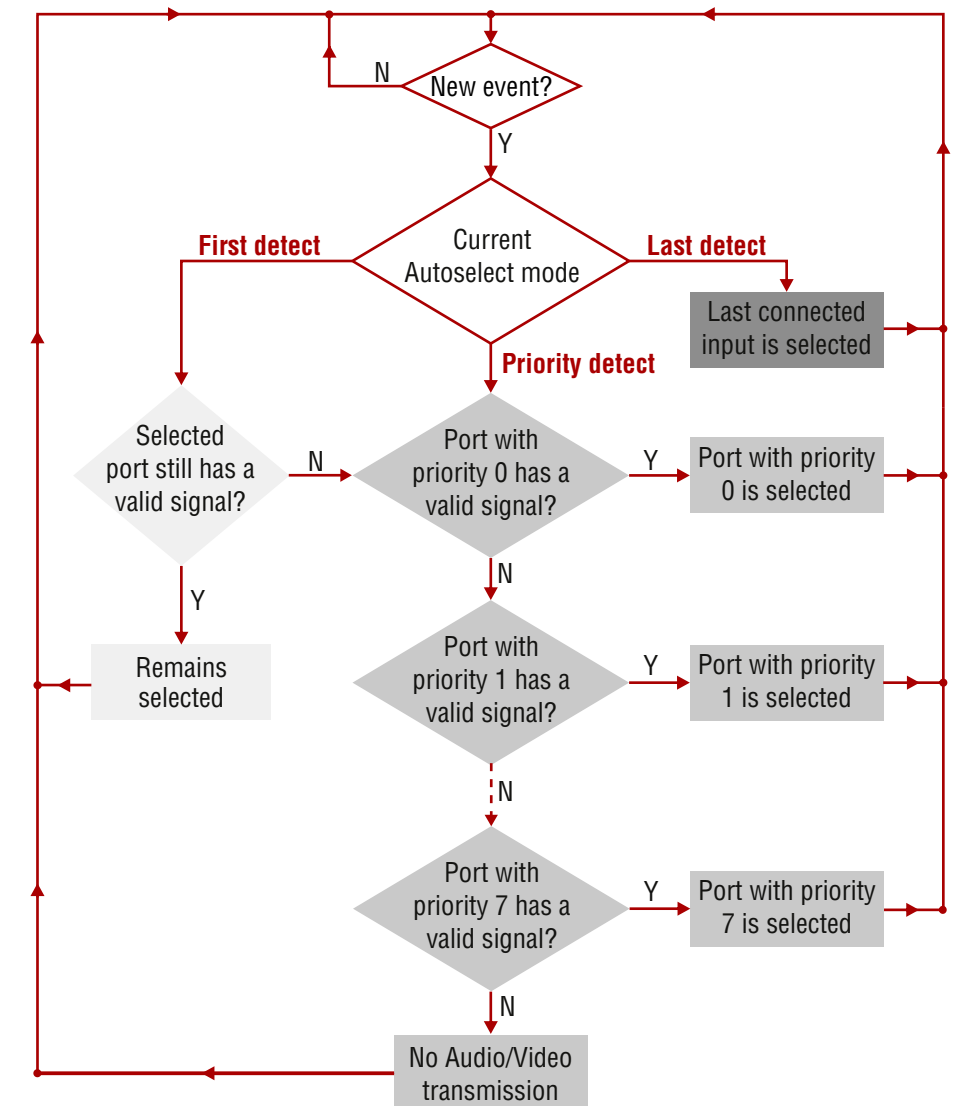

11.7. Port Numbering

11.7.1. MMX8x4-HT400MC

Audio/Video Ports

Port name	Video port nr. (LW2)	Video port nr. (LW3)	Emulated EDID memory	Audio port nr. (LW2)	Audio port nr. (LW3)
TPS IN 1	01	I1	F47	-	I1
TPS IN 2	02	I2	F47	-	I2
TPS IN 3	03	I3	F47	-	I3
TPS IN 4	04	I4	F47	-	I4
HDMI IN 5	05	I5	F47	-	I5
HDMI IN 6	06	I6	F47	-	I6
HDMI IN 7	07	I7	F47	-	I7
HDMI IN 8	08	I8	F47	-	I8
MIC INPUT	-	-	-	-	I9
BAL. INPUT	-	-	-	-	I10
<video_port_name>	-	-	-	-	I11
HDMI OUT 1	01	O1	-	-	O1
HDMI OUT 2	02	O2	-	-	O2
HDMI OUT 3	03	O3	-	-	O3
HDMI OUT 4	04	O4	-	-	O4
AUDIO OUT	05	O5	-	-	-
BAL. OUT	-	-	-	-	O6

RS-232 Ports

Port name	Port nr. (LW2 / LW3)	Command injection port nr.
Rs232 1	P1	8001
Rs232 2	P2	8002
Uart3 Ir1 Mixed	P3	8003
Uart4 Ir2 Mixed	P4	8004
TPS IN 1	P5	8005
TPS IN 2	P6	8006
TPS IN 3	P7	8007
TPS IN 4	P8	8008

IR Ports

Port name	Port nr. (LW2 / LW3)	Command injection port nr.
IR1 Uart3 Mixed	D1	9001
IR2 Uart4 Mixed	D2	9002
IR3	D3	9003
IR4	D4	9004

Ethernet

Port name	Port nr. (LW2 / LW3)
CPU	P1
Control	P2

11.7.2. MMX8x8-HDMI-4K-A

Audio/Video Ports

Port name	Video port nr. (LW2)	Video port nr. (LW3)	Emulated EDID memory	Audio port nr. (LW2)	Audio port nr. (LW3)
HDMI IN 1	01	I1	F47	-	I1
HDMI IN 2	02	I2	F47	-	I2
HDMI IN 3	03	I3	F47	-	I3
HDMI IN 4	04	I4	F47	-	I4
HDMI IN 5	05	I5	F47	-	I5
HDMI IN 6	06	I6	F47	-	I6
HDMI IN 7	07	I7	F47	-	I7
HDMI IN 8	08	I8	F47	-	I8
HDMI OUT 1	01	O1	-	-	O1
HDMI OUT 2	02	O2	-	-	O2
HDMI OUT 3	03	O3	-	-	O3
HDMI OUT 4	04	O4	-	-	O4
HDMI OUT 5	05	O5	-	-	O5
HDMI OUT 6	06	O6	-	-	O6
HDMI OUT 7	07	O7	-	-	O7
HDMI OUT 8	08	O8	-	-	O7

RS-232 Ports

Port name	Port nr. (LW2 / LW3)	Command injection port nr.
Uart 1	P1	8001
Uart 2	P2	8002
Uart3 Mixed	P3	8003
Uart4 Mixed	P4	8004

IR Ports

Port name	Port nr. (LW2 / LW3)	Command injection port nr.
IR output	D1	9001
IR output	D2	9002
IR output	D3	9003
IR output	D4	9004

Ethernet

Port name	Port nr. (LW3)
CPU	P1
Control	P2

11.7.3. MMX8x4-HT420M

Audio/Video Ports

Port name	Video port nr. (LW2)	Video port nr. (LW3)	Emulated EDID memory	Audio port nr. (LW2)	Audio port nr. (LW3)
TPS IN 1	01	I1	F47	-	I1
TPS IN 2	02	I2	F47	-	I2
TPS IN 3	03	I3	F47	-	I3
TPS IN 4	04	I4	F47	-	I4
HDMI IN 5	05	I5	F47	-	I5
HDMI IN 6	06	I6	F47	-	I6
HDMI IN 7	07	I7	F47	-	I7
HDMI IN 8	08	I8	F47	-	I8
MIC INPUT	-	-	-	-	I9
BAL. INPUT	-	-	-	-	I10
<video_port_name>			-	-	I11
TPS OUT 1	01	O1	-	-	O1
TPS OUT 2	02	O2	-	-	O2
HDMI OUT 3	03	O3	-	-	O3
HDMI OUT 4	04	O4	-	-	O4
AUDIO OUT	05	O5	-	-	-
BAL. OUT	-	-	-	-	O6

RS-232 Ports

Port name	Port nr. (LW2 / LW3)	Command injection port nr.
Rs232 1	P1	8001
Rs232 2	P2	8002
Uart3 Ir1 Mixed	P3	8003
Uart4 Ir2 Mixed	P4	8004
TPS IN 1	P5	8005
TPS IN 2	P6	8006
TPS IN 3	P7	8007
TPS IN 4	P8	8008
TPS OUT 1	P9	8009
TPS OUT 2	P10	8010

Ethernet

Port name	Port nr. (LW2 / LW3)
CPU	P1
Control	P2
Uplink TPS Out	P3
Uplink TPS In	P4
TPS IN 1	P5
TPS IN 2	P6
TPS IN 3	P7
TPS IN 4	P8
TPS OUT 1	P9
TPS OUT 2	P10

IR Ports

Port name	Port nr. (LW2 / LW3)	Command injection port nr.
IR1 Uart3 Mixed	D1	9001
IR2 Uart4 Mixed	D2	9002
IR3	D3	9003
IR4	D4	9004
IR5	D5	9005
IR6	D6	9006

GPIO

Port name	Port nr. (LW2)	Port nr. (LW3)
Gpio1	1	P1
Gpio2	2	P2
Gpio3	3	P3
Gpio4	4	P4
Gpio5	5	P5
Gpio6	6	P6

Relay

Port name	Port nr. (LW2)	Port nr. (LW3)
Relay1	1	P1
Relay2	2	P2
Relay3	3	P3
Relay4	4	P4

11.8. Conditions in the Wizard Tab of the Event Manager

General Category

Condition		
Expression	HT400MC Ports	HT420M Ports
TPS link state changes to Connected on a port	I1- I4	I1- I4; O1-02
TPS link state changes to Disconnected on a port	I1- I4	I1- I4; O1-02

Video Category

Condition			
Expression	HT400MC Ports	HT420M Ports	HDMI-4K-A Ports
Signal is detected on a port	I1-I8; O1-05	I1-I8; O1-05	I1-I8; O1-08
Signal is not detected on a port	I1-I8; O1-05	I1-I8; O1-05	I1-I8; O1-08
Signal type change to DVI	I1-I8; O1-05	I1-I8; O1-05	I1-I8; O1-08
Signal type change to HDMI	I1-I8; O1-05	I1-I8; O1-05	I1-I8; O1-08
Signal type changes to Undefined (no signal)	I1-I8; O1-05	I1-I8; O1-05	I1-I8; O1-08

Audio Category

Condition			
Expression	HT400MC Ports	HT420M Ports	HDMI-4K-A Ports
Signal is detected on a port	I1-I8; O1-04	I1-I8; O1-04	I1-I8; O1-08
Signal is not detected on a port	I1-I8; O1-04	I1-I8; O1-04	I1-I8; O1-08
Signal type change to PCM	I1-I8; O1-04	I1-I8; O1-04	I1-I8; O1-08
Signal type change to Compressed	I1-I8; O1-04	I1-I8; O1-04	I1-I8; O1-08
Signal type change to HBR	I1-I8; O1-04	I1-I8; O1-04	I1-I8; O1-08
Signal type changes to Undefined (no signal)	I1-I8; O1-04	I1-I8; O1-04	I1-I8; O1-08

GPIO Category

Condition	
Expression	HT420M Ports
State changes to 'High'	P1-P6
State changes to 'Low'	P1-P6

11.9. Actions in the Wizard Tab of the Event Manager

Video Category

Action					
Expression	Parameters HT400MC		Parameters HT420M		Parameters HDMI-4K-A
Switch input to output	I1-I8	O1-05	I1-I8	O1-05	I1-I8 O1-08
Enable autoselect on output	O1-05		O1-05		O1-08
Disable autoselect on output	O1-05		O1-05		O1-08
Load crosspoint preset	Preset1 - Preset8		Preset1 - Preset8		Preset1 - Preset8
Mute input	I1-I8		I1-I8		I1-I8
Mute output	O1-05		O1-05		O1-08
Unmute input	I1-I8		I1-I8		I1-I8
Unmute output	O1-05		O1-05		O1-08

RS-232 Category

Action				
Expression	HT400MC Ports	HT420M Ports	HDMI-4K-A Ports	Parameter
Send RS-232 message	P1-P8	P1-P10	P1-P4	Message

Infra Category

Action				
Expression	HT400MC Ports	HT420M Ports	HDMI-4K-A Ports	Parameters
Send pronto hex code	D1-D4	D1-D6	D1-D4	Pronto hex

Audio Category

Action		
Expression	Parameters HT400MC	Parameters HT420M
Set Mic input channel volume on mixer	Volume: 0dB to -80dB	
Increase Mic input channel volume on mixer	N/A	
Decrease Mic input channel volume on mixer	N/A	
Mute Mic input channel volume on mixer	N/A	
Unmute Mic input channel volume on mixer	N/A	
Set Line input channel volume on mixer	Volume: 0dB to -80dB	
Increase Line input channel volume on mixer	N/A	
Decrease Line input channel volume on mixer	N/A	
Mute Line input channel volume on mixer	N/A	
Unmute Line input channel volume on mixer	N/A	
Set HDMI input channel volume on mixer	Volume: 0dB- to -80dB	
Increase HDMI input channel volume on mixer	N/A	
Decrease HDMI input channel volume on mixer	N/A	
Mute HDMI input channel volume on mixer	N/A	
Unmute HDMI input channel volume on mixer	N/A	
Set Line output channel volume on mixer	N/A	
Increase Line output channel volume on mixer	N/A	
Decrease Line output channel volume on mixer	N/A	
Mute Line output channel volume on mixer	N/A	
Unmute Line output channel volume on mixer	N/A	

Ethernet Category

Action			
Expression	HT400MC Parameters	HT420M Parameters	HDMI-4K-A Parameters
Send TCP command	Message, IP address, Port number		
Send UTP command	Message, IP address, Port number		

INFO: The maximum length of the code can be 184 characters (184bytes).

EDID Category

Action						
Expression	Parameters HT400MC		Parameters HT420M		Parameters HDMI-4K-A	
Switch EDID	F1-F149 D1-D5 U1-U27	E1-E8	F1-F149 D1-D5 U1-U27	E1-E8	F1-F149 D1-D8 U1-U24	E1-E8

GPIO Category

Action	
Expression	HT420M Ports
Open contact on relay	P1-P4
Close contact on relay	P1-P4
Toggle contact on relay	P1-P4

CEC Category

Action		
Expression	HT420M Ports	Parameters
Send command '<cec_command_text>'	I1-I8; O1-O5	N/A
Send custom command	I1-I8; O1-O5	CEC command in hex format

INFO: For the entire list of CEC commands see [Sending CEC Commands](#) section.

11.10. Factory EDID List

Mem.	Resolution			Type
F1	640 x	480	@ 60.00 Hz	D
F2	848 x	480	@ 60.00 Hz	D
F3	800 x	600	@ 60.32 Hz	D
F4	1024 x	768	@ 60.00 Hz	D
F5	1280 x	768	@ 50.00 Hz	D
F6	1280 x	768	@ 59.94 Hz	D
F7	1280 x	768	@ 75.00 Hz	D
F8	1360 x	768	@ 60.02 Hz	D
F9	1280 x	1024	@ 50.00 Hz	D
F10	1280 x	1024	@ 60.02 Hz	D
F11	1280 x	1024	@ 75.02 Hz	D
F12	1400 x	1050	@ 50.00 Hz	D
F13	1400 x	1050	@ 60.00 Hz	D
F14	1400 x	1050	@ 75.00 Hz	D
F15	1680 x	1050	@ 60.00 Hz	D
F16	1920 x	1080	@ 50.00 Hz	D
F17	1920 x	1080	@ 60.00 Hz	D
F18	2048 x	1080	@ 50.00 Hz	D
F19	2048 x	1080	@ 60.00 Hz	D
F20	1600 x	1200	@ 50.00 Hz	D
F21	1600 x	1200	@ 60.00 Hz	D
F22	1920 x	1200	@ 50.00 Hz	D
F23	1920 x	1200	@ 59.56 Hz	D
F24	2048 x	1200	@ 59.96 Hz	D
F29	1920 x	1080	@ 60.00 Hz	U
F30	1440 x	480	@ 60.05 Hz	H
F31	1440 x	576	@ 50.08 Hz	H
F32	640 x	480	@ 59.95 Hz	H
F33	720 x	480	@ 59.94 Hz	H
F34	720 x	576	@ 50.00 Hz	H

Mem.	Resolution			Type
F35	1280 x	720	@ 50.00 Hz	H
F36	1280 x	720	@ 60.00 Hz	H
F37	1920 x	1080	@ 50.04 Hz	H
F38	1920 x	1080	@ 50.00 Hz	H
F39	1920 x	1080	@ 60.05 Hz	H
F40	1920 x	1080	@ 60.05 Hz	H
F41	1920 x	1080	@ 24.00 Hz	H
F42	1920 x	1080	@ 25.00 Hz	H
F43	1920 x	1080	@ 30.00 Hz	H
F44	1920 x	1080	@ 50.00 Hz	H
F45	1920 x	1080	@ 59.94 Hz	H
F46	1920 x	1080	@ 60.00 Hz	H
F47	1920 x	1080	@ 60.00 Hz	U
F48	1920 x	1080	@ 60.00 Hz	U
F49	1920 x	1080	@ 60.00 Hz	U
F90	1920 x	2160	@ 59.99 Hz	D
F91	1024 x	2400	@ 60.01 Hz	D
F94	2048 x	1536	@ 60.00 Hz	D
F96	2560 x	1600	@ 59.86 Hz	D
F97	3840 x	2400	@ 24.00 Hz	D
F98	1280 x	720	@ 60.00 Hz	H
F99	1920 x	1080	@ 60.00 Hz	H
F100	1024 x	768	@ 60.00 Hz	H
F101	1280 x	1024	@ 50.00 Hz	H
F102	1280 x	1024	@ 60.02 Hz	H
F103	1280 x	1024	@ 75.02 Hz	H
F104	1600 x	1200	@ 50.00 Hz	H
F105	1600 x	1200	@ 60.00 Hz	H
F106	1920 x	1200	@ 59.56 Hz	H
F107	2560 x	1440	@ 59.95 Hz	H

Mem.	Resolution			Type
F108	2560 x	1600	@ 59.86 Hz	H
F109	3840 x	2400	@ 24.00 Hz	H
F110	3840 x	2160	@ 24.00 Hz	H
F111	3840 x	2160	@ 25.00 Hz	H
F112	3840 x	2160	@ 30.00 Hz	H
F118	3840 x	2160	@ 30.00 Hz	U
F119	3840 x	2160	@ 30.00 Hz	U
F120	3840 x	2160	@ 60.00 Hz	H
F149	3840 x	2160	@ 50.00 Hz	H

Legend

D: DVI EDID

H: HDMI EDID

U Universal EDID (supporting many common EDIDs)

Please note that minor changes in the factory EDID list may be applied in farther firmware versions.

11.11. Audio Cable Wiring Guide

Inputs and outputs of audio devices are symmetric or asymmetric. The main advantage of the symmetric lines is the better protection against the noise therefore, they are widely used in the professional audio industry. Symmetric audio is most often referred to as balanced audio, as opposed to asymmetric, which is referred to as unbalanced audio. Lightware products are usually built with 5-pole Phoenix connectors so we would like to help users assembling their own audio cables. See the most common cases below.

ATTENTION! Symmetric and asymmetric lines can be linked with passive accessories (e.g. special cables), but in this case half of the line level is lost.

ATTENTION! There are numerous types of regularly used connector and cable types to connect audio devices. Please always make sure that a connector or cable fits your system before use.

ATTENTION! Never join the phase-inverted (negative, cold or -) poles (either right and left) to the ground or to each other on the output side, as this can damage the unit.

INFO: Use a galvanic isolation in case of a ground loop.

The Pinout of the 5-pole Phoenix Connector



Pin nr.	Signal
1	Left+
2	Left-
3	Ground
4	Right-
5	Right+

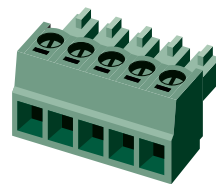

Compatible Plug Type

Phoenix® Combicon series (3.5mm pitch, 5-pole), type: MC 1.5/5-ST-3.5.

From Unbalanced Output to Balanced Input

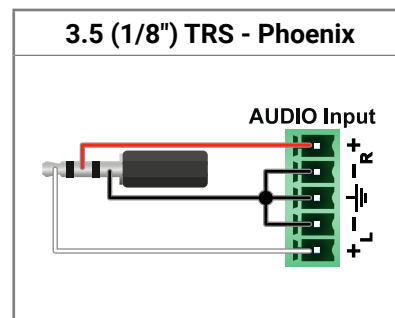
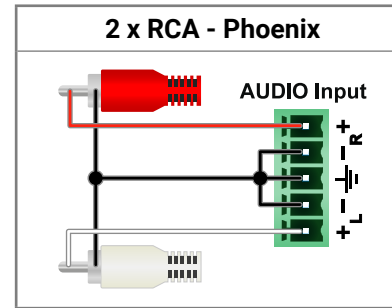
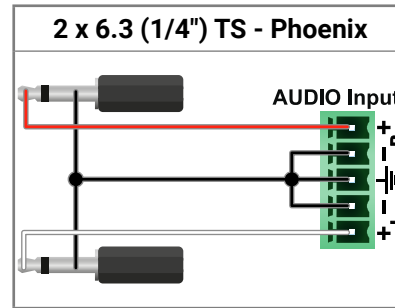

From Balanced Output to Unbalanced Input

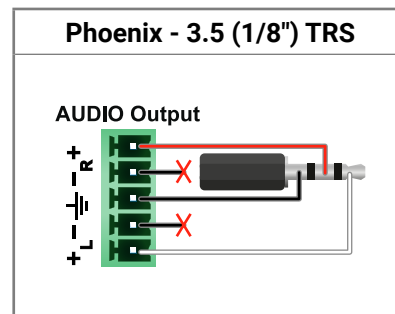
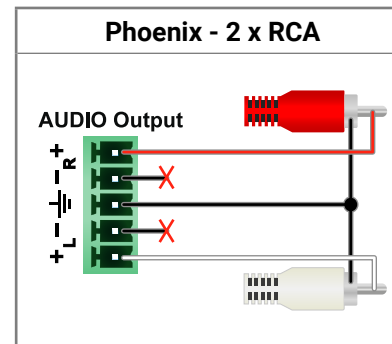
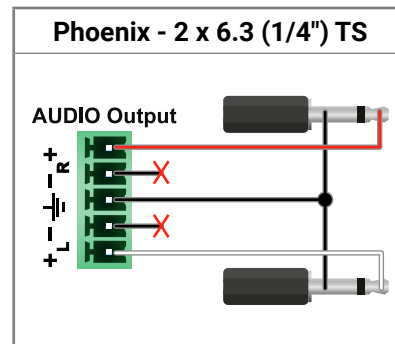

From Balanced Output to Balanced Input

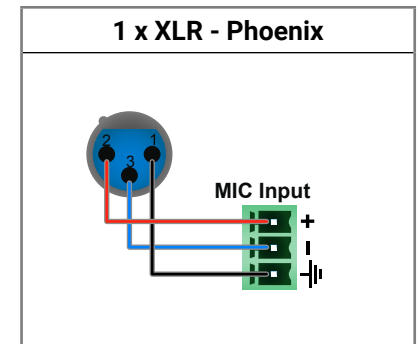
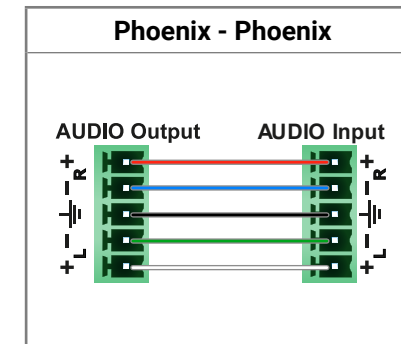
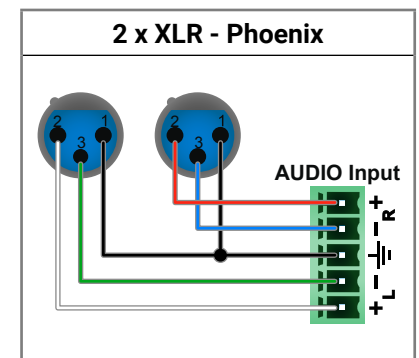
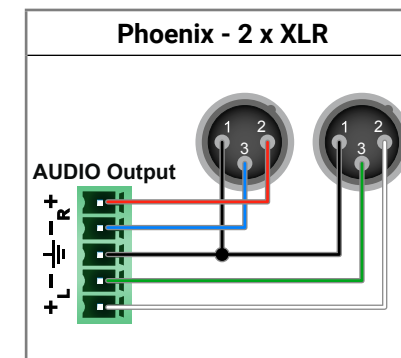
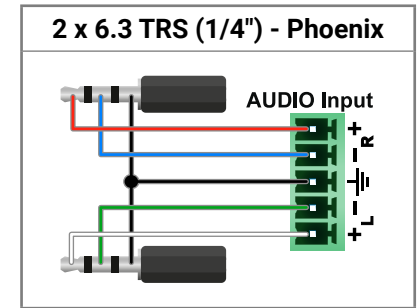
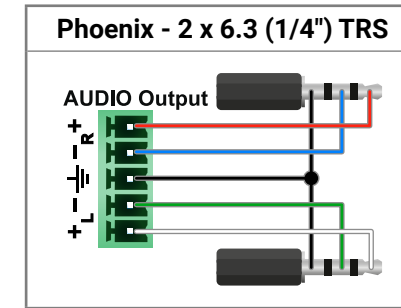

ATTENTION! Always check the correct wiring of the microphone cable! Never apply phantom power with unbalanced cable, because it can cause a damage!

Microphone cable should be shielded with 2x0.22mm conductor, max. 50m long.

11.12. Further Information

Limited Warranty Statement

1. Lightware Visual Engineering LLC (Lightware) warrants to all trade and end user customers that any Lightware product purchased will be free from manufacturing defects in both material and workmanship for three (3) years from purchase unless stated otherwise below. The warranty period will begin on the latest possible date where proof of purchase/delivery can be provided by the customer. In the event that no proof can be provided (empty 'Date of purchase' field or a copy of invoice), the warranty period will begin from the point of delivery from Lightware.

1.1. 25G and MODEX product series will be subject to a seven (7) year warranty period under the same terms as outlined in this document.

1.2. If during the first three (3) months of purchase, the customer is unhappy with any aspect of a Lightware product, Lightware will accept a return for full credit.

1.3. Any product that fails in the first six (6) months of the warranty period will automatically be eligible for replacement and advanced replacement where available. Any replacements provided will be warranted for the remainder of the original unit's warranty period.

1.4. Product failures from six (6) months to the end of the warranty period will either be repaired or replaced at the discretion of Lightware. If Lightware chooses to replace the product then the replacement will be warranted for the remainder of the original unit's warranty period.

2. The above-stated warranty and procedures will not apply to any product that has been:

2.1. Modified, repaired or altered by anyone other than a certified Lightware engineer unless expressly agreed beforehand.

2.2. Used in any application other than that for which it was intended.

2.3. Subjected to any mechanical or electrical abuse or accidental damage.

2.4. Any costs incurred for repair/replacement of goods that fall into the above categories (2.1., 2.2., 2.3.) will be borne by the customer at a pre-agreed figure.

3. All products to be returned to Lightware require a return material authorization number (RMA) prior to shipment and this number must be clearly marked on the box. If an RMA number is not obtained or is not clearly marked on the box, Lightware will refuse the shipment.

3.1. The customer will be responsible for in-bound and Lightware will be responsible for out-bound shipping costs.

3.2. Newly repaired or replaced products will be warranted to the end of the originally purchased products warranty period.

Document Revision History

Rev.	Release date	Changes	Editor
1.0	28.04.2018	Initial version	Judit Barsony
1.1	16.05.2018	Model comp. table, new LW3 progref. format, troubleshooting chapter	Judit Barsony
1.2	03.09.2018	Add CEC function description, audio preset and scene description, IR message sending description, EM Wizard table in the appendix, add more details to the specification.	Judit Barsony
1.3	31.10.2018	1080p120Hz signal support info added	Judit Barsony
1.4	26.02.2019	Minor typo corrections	Judit Barsony

Contact Us

sales@lightware.com

+36 1 255 3800

support@lightware.com

+36 1 255 3810

Lightware Visual Engineering LLC.

Peterdy 15, Budapest H-1071, Hungary

www.lightware.com