

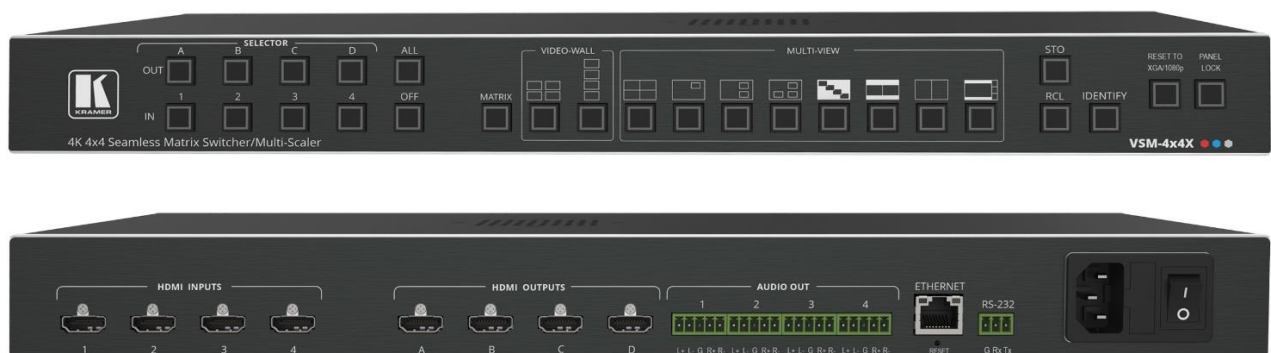

# USER MANUAL

## MODEL:

**VSM-4x4x**  
**4K 4x4 Seamless Matrix**  
**Switcher/Multi-Scaler**



# Contents

<b>Introduction</b>	<b>1</b>
Getting Started	1
Overview	2
Typical Applications	3
<b>Defining VSM-4x4x</b>	<b>4</b>
<b>Mounting VSM-4x4x</b>	<b>6</b>
<b>Connecting VSM-4x4x</b>	<b>7</b>
Connecting the Output to a Balanced/Unbalanced Stereo Audio Acceptor	8
Connecting to VSM-4x4x via RS-232	8
<b>Operating VSM-4x4x Via the Front Panel Buttons</b>	<b>9</b>
Storing and Recalling a Preset	9
Switching an Input to an Output in the Matrix Mode	10
Selecting a Multi-View Mode Configuration	10
Selecting a Video Wall Configuration	11
<b>Operating via Ethernet</b>	<b>13</b>
<b>Using Embedded Web Pages</b>	<b>16</b>
Defining AV Settings	17
Operating and Controlling in the Matrix Mode	22
Operating and Controlling in the Multi-View Mode	23
Operating and Controlling the Video Wall Mode	40
Managing EDID	44
Defining General Settings	45
Defining Interface Settings	48
Defining VSM-4x4x User Access	49
Viewing the About Page	51
<b>Upgrading the Firmware</b>	<b>52</b>
<b>Technical Specifications</b>	<b>53</b>
Default Communication Parameters	54
Default EDID	54
<b>Protocol 3000</b>	<b>57</b>
Understanding Protocol 3000	57
Protocol 3000 Commands	58
Result and Error Codes	76

# Introduction

Welcome to Kramer Electronics! Since 1981, Kramer Electronics has been providing a world of unique, creative, and affordable solutions to the vast range of problems that confront the video, audio, presentation, and broadcasting professional on a daily basis. In recent years, we have redesigned and upgraded most of our line, making the best even better!

---

## Getting Started

We recommend that you:

- Unpack the equipment carefully and save the original box and packaging materials for possible future shipment.
- Review the contents of this user manual.



Go to [www.kramerav.com/downloads/VSM-4x4x](http://www.kramerav.com/downloads/VSM-4x4x) to check for up-to-date user manuals, application programs, and to check if firmware upgrades are available (where appropriate).

## Achieving Best Performance

- Use only good quality connection cables (we recommend Kramer high-performance, high-resolution cables) to avoid interference, deterioration in signal quality due to poor matching, and elevated noise levels (often associated with low quality cables).
- Do not secure the cables in tight bundles or roll the slack into tight coils.
- Avoid interference from neighboring electrical appliances that may adversely influence signal quality.
- Position your Kramer **VSM-4x4x** away from moisture, excessive sunlight and dust.

## Safety Instructions



### Caution:

- This equipment is to be used only inside a building. It may only be connected to other equipment that is installed inside a building.
- For products with relay terminals and GPIO ports, please refer to the permitted rating for an external connection, located next to the terminal or in the User Manual.
- There are no operator serviceable parts inside the unit.



### Warning:

- Use only the power cord that is supplied with the unit.
- Disconnect the power and unplug the unit from the wall before installing.
- Do not open the unit. High voltages can cause electrical shock! Servicing by qualified personnel only.
- To ensure continuous risk protection, replace fuses only according to the rating specified on the product label which is located on the bottom of the unit.

## Recycling Kramer Products

The Waste Electrical and Electronic Equipment (WEEE) Directive 2002/96/EC aims to reduce the amount of WEEE sent for disposal to landfill or incineration by requiring it to be collected and recycled. To comply with the WEEE Directive, Kramer Electronics has made arrangements with the European Advanced Recycling Network (EARN) and will cover any costs of treatment, recycling and recovery of waste Kramer Electronics branded equipment on arrival at the EARN facility. For details of Kramer's recycling arrangements in your particular country go to our recycling pages at [www.kramerav.com/il/quality/environment](http://www.kramerav.com/il/quality/environment).

---

## Overview

Congratulations on purchasing your Kramer **VSM-4x4x 4K 4x4 Seamless Matrix Switcher/Multi-Scaler**. The **VSM-4x4x** is a 4X4 seamless matrix switcher that can also be used as a video wall driver (2X2 or 1X4), a quad-viewer, or a 4 picture multi-viewer. The unit allows instantaneous switching between inputs (that is, with a clean, frame-to-frame video cut). The **VSM-4x4x** supports HDMI 2.0 and HDCP 2.2, with resolutions up to 4K60 4:4:4, per-port HDCP and EDID settings, passing of 4 channels of embedded audio, and analog stereo de-embedded audio for each of the 4 outputs.

**VSM-4x4x** provides exceptional quality, advanced and user-friendly operation, and flexible connectivity.

## Exceptional Quality

- PixPerfect™ Scaling Technology – Kramer's precision pixel mapping and high quality scaling technology.
- Matrix Switching Modes – Truly seamless switching mode (zero-time video cuts), or fade-through-black mode (enabling independent output resolutions).
- Built-in ProcAmp – Color, hue, sharpness, noise, contrast and brightness.
- Multiple Aspect Ratio Selections – Full, 4:3, 16:9 and best fit.
- 4 Preset Memory Locations – For each operation mode for quick access to common IN-OUT configurations.
- Non-Volatile Memory – Saves final settings.
- Built-in noise reduction and picture enhancement features.
- HDMI Support – 4K@60Hz, Deep Color, x.v.Color™, 7.1 PCM, Dolby TrueHD, DTS-HD, as specified in HDMI 2.0.

## Advanced and User-friendly Operation

- Selectable Operation Modes – 4x4 matrix switcher, video wall (2x2 or 1x4 configuration), multi-view display Split, Side-by-Side, PIP, POP, Stacked or Quad display.
- Bezel Correction Options – In video wall mode.
- Constant Output Sync – For all modes of operation.
- Multiple aspect ratio selections.

- STO, RCL and IDENTIFY buttons, a RESET TO XGA/1080P button (to hardware-reset the output resolution) and a PANEL LOCK button.
- Built-in video Proc-Amp – color, hue, sharpness, contrast, and brightness are set individually for each input.
- Firmware Upgrade – Ethernet-based, via a user-friendly software upgrade tool.
- Advanced EDID management per input.
- Includes non-volatile memory that retains the last settings, after switching the power off and then on again.

## Flexible Connectivity

- 4 HDMI Inputs and 4 Scaled HDMI Outputs.
- 4 balanced audio outputs with independent volume settings per output, embedded audio on the HDMI inputs and outputs.

---

## Typical Applications

VSM-4x4x is ideal for the following typical applications:

- Presentation and multimedia.
- Projection systems in conference rooms, boardrooms, auditoriums, hotels and churches, production studios, rental and staging.
- Video wall: large signage applications in public places.
- Any application where high quality conversion and switching of multiple and different video signals to graphical data signals is required for display or projection purposes.

## Controlling your VSM-4x4x

Control your VSM-4x4x directly via the front panel push buttons (with on-screen menus, or:

- Via the Ethernet using built-in user-friendly Web pages.
- By RS-232 serial commands transmitted by a touch screen system, PC, or other serial controller.

# Defining VSM-4x4x

This section defines **VSM-4x4x**.

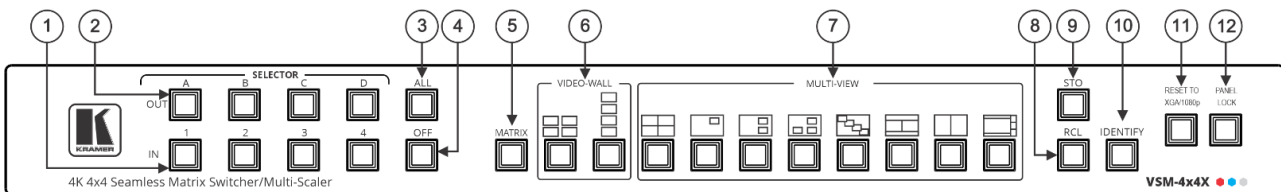











Figure 1: VSM-4x4x 4K 4x4 Seamless Matrix Switcher/Multi-Scaler Front Panel

#	Feature	Function
①	IN SELECTOR Buttons	Press to select an HDMI input (from 1 to 4) to switch to an output or a window. Press together with STO/RCL buttons to store a configuration and recall it when required (see <a href="#">Storing and Recalling a Preset</a> on page 9).
②	OUT SELECTOR Buttons	In the MATRIX mode: select the output to which the input is switched (A, B, C or D). In the VIDEO WALL mode: not used. In the MULTI-VIEW mode: select the input for each window on the display.
③	ALL Button	Press ALL followed by an INPUT button to connect that input to all the outputs (not available for the video wall mode).
④	OFF Button	Press after pressing an output button to disconnect the selected output from the inputs. To disconnect all the outputs, press ALL followed by OFF.
⑤	MATRIX Mode	Press to operate the system as a matrix switcher.
⑥	VIDEO-WALL Mode	Press to operate as a video wall. 2x2  Configure a 2x2 video wall. 1x4  Configure a 1x4 video wall.
⑦	MULTI-VIEW Mode	Press to operate in multi-view configurations: Quad  4 windows filling the display. PiP  1 window over a background image.  2 windows over a background image.  3 windows over a background image. Stacked  4 images, overlapping (maintaining aspect ratio). PoP  2 images, side-by-side (maintaining aspect ratio).  2 images, displayed as a split-screen (elongated images).  1 large window and 3 smaller images on the side (maintaining aspect ratio).
⑧	RCL Button	Press, followed by an input button, to recall a configuration.
⑨	STO Button	Press, followed by an input button, to store a configuration.
⑩	IDENTIFY Button	Press to indicate which input is displayed on each output or window.
⑪	RESET TO XGA/1080p Button	Press and hold for about 5 seconds to toggle resetting the video resolution to XGA or 1080p.
⑫	PANEL LOCK Button	Press and hold for about 5 seconds to toggle locking the front panel buttons.

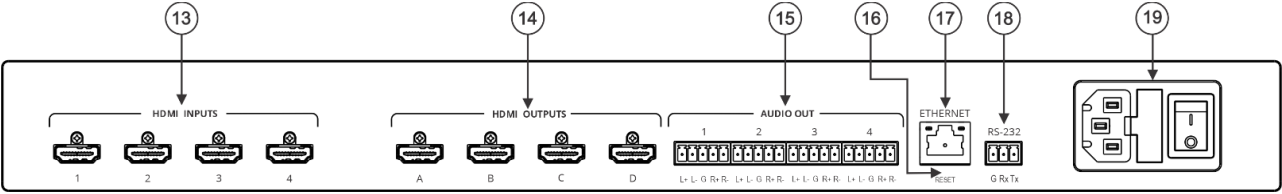

Figure 2: VSM-4x4x 4K 4x4 Seamless Matrix Switcher/Multi-Scaler Rear Panel

#	Feature	Function
13	HDMI INPUT Connectors	Connect to the HDMI sources (from 1 to 4).
14	HDMI OUTPUT Connectors	Connect to HDMI acceptors (from A to D).
15	AUDIO OUT 5-pin Terminal Block Connector	Connect to a balanced audio acceptor (from 1 to 4).
16	RESET Recessed button	Press and hold while powering the device to reset to factory default parameters.
17	ETHERNET Connector	Connect to the PC or other Serial Controller through computer networking.
18	RS-232 3-pin Terminal Block Connector	Connect to the PC or a remote controller.
19	Mains Power Connector, Fuse and Switch	Connect to the mains supply and use the switch to turn the unit on or off.

# Mounting VSM-4x4x

This section provides instructions for mounting **VSM-4x4x**. Before installing, verify that the environment is within the recommended range:



- Operation temperature – 0° to 40°C (32 to 104°F).
- Storage temperature – -40° to +70°C (-40 to +158°F).
- Humidity – 10% to 90%, RHL non-condensing.

**Caution:**

- Mount **VSM-4x4x** before connecting any cables or power.

**Warning:**

- Ensure that the environment (e.g., maximum ambient temperature & air flow) is compatible for the device.
- Avoid uneven mechanical loading.
- Appropriate consideration of equipment nameplate ratings should be used for avoiding overloading of the circuits.
- Reliable earthing of rack-mounted equipment should be maintained.

**Mount VSM-4x4x in a rack:**

- Attach both rack ears by removing the screws from each side of the machine and replacing those screws through the rack ears.

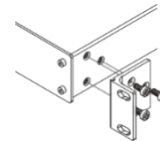



# Connecting VSM-4x4x



Always switch off the power to each device before connecting it to your **VSM-4x4x**. After connecting your **VSM-4x4x**, connect its power and then switch on the power to each device.

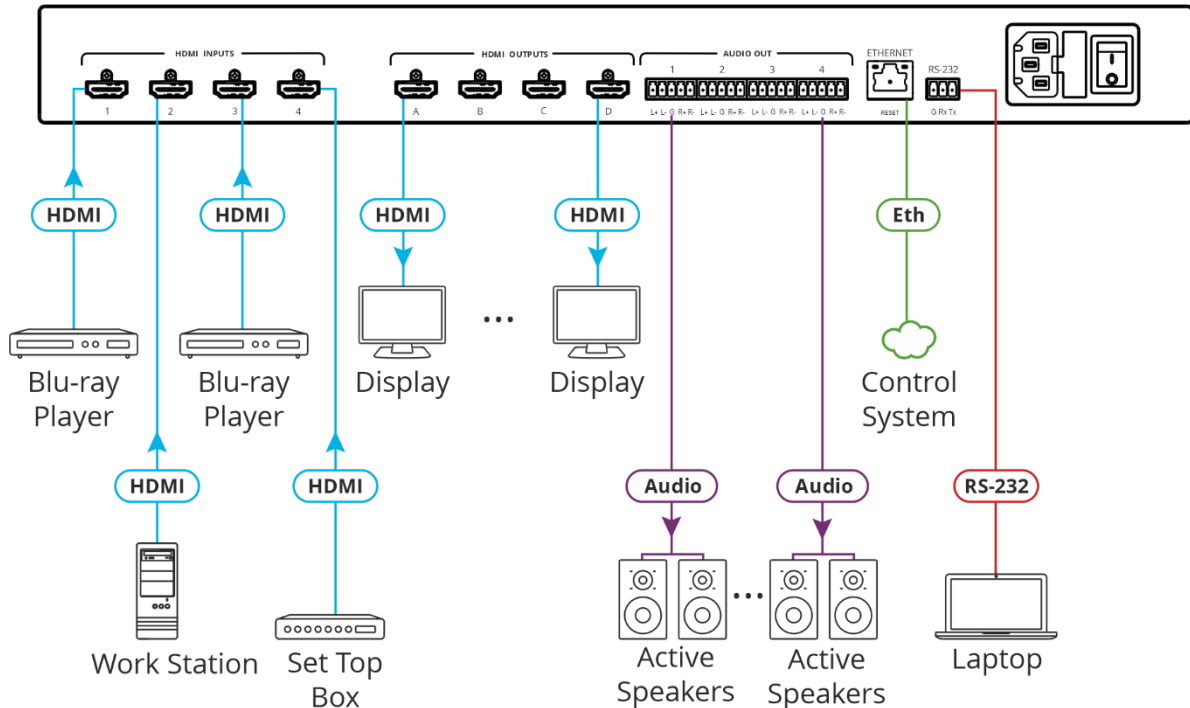

Figure 3: Connecting to the VSM-4x4x Rear Panel

To connect VSM-4x4x as illustrated in the example in [Figure 3](#):

1. Connect up to 4 HDMI sources (for example, a Blu-ray player, a set top box, a work station, and so on) to the HDMI INPUT connectors (13).
2. Connect the 4 HDMI outputs (14) to up to four HDMI acceptors (for example, displays).
3. Connect the 4 AUDIO OUT 5-pin terminal block connectors to (15) to up to 4 balanced stereo audio acceptors (for example, Kramer active speakers).
4. Connect the ETHERNET RJ-45 port (17) to a control system.
5. Connect the RS-232 3-pin terminal block connector (18) to a laptop.
6. Connect the power to the mains electricity (not shown in [Figure 3](#)).

# Connecting the Output to a Balanced/Unbalanced Stereo Audio Acceptor

The following are the pinouts for connecting the output to a balanced or unbalanced stereo audio acceptor:

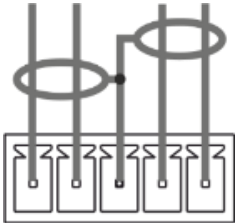

L+ L- G R+ R-

Figure 4: Connecting to a Balanced Stereo Audio Acceptor

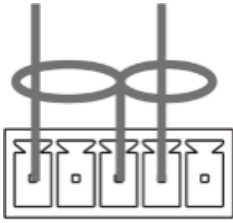

L+ L- G R+ R-

Figure 5: Connecting to an Unbalanced Stereo Audio Acceptor

# Connecting to VSM-4x4x via RS-232

You can connect to **VSM-4x4x** via an RS-232 connection (18) using, for example, a PC.

**VSM-4x4x** features an RS-232 3-pin terminal block connector allowing the RS-232 to control **VSM-4x4x**.

Connect the RS-232 terminal block on the rear panel of **VSM-4x4x** to a PC/controller, as follows:

From the RS-232 9-pin D-sub serial port connect:

- Pin 2 to the TX pin on the **VSM-4x4x** RS-232 terminal block
- Pin 3 to the RX pin on the **VSM-4x4x** RS-232 terminal block
- Pin 5 to the G pin on the **VSM-4x4x** RS-232 terminal block

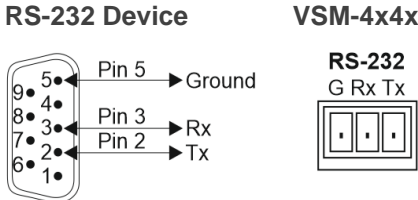

# Operating VSM-4x4x Via the Front Panel Buttons

VSM-4x4x front panel buttons enable performing the following functions:

- [Storing and Recalling a Preset](#) on page [9](#).
- [Switching an Input to an Output in the Matrix Mode](#) on page [10](#).
- [Selecting a Multi-View Mode Configuration](#) on page [10](#).
- [Selecting a Video Wall Configuration](#) on page [11](#).

---

## Storing and Recalling a Preset

Store and recall user presets via the INPUT front panel buttons or via the P3K commands (see [Protocol 3000 Commands](#) on page [58](#)).

Inputs 1 to 4 can store 4 device presets, which can be recalled when needed.

Each preset stores:

- The video mode (matrix, multi-view and video wall different modes).
- Video saturation, contrast and brightness.
- Borders, labels and their properties (for example, color and background color).
- Audio settings (for example, mute state and volume settings).

Presets 1 to 4 can be stored via input



Last preset is recalled at power up.

## Storing a Preset

You can store 4 presets via the front panel input buttons (1 to 4).

**To store a preset:**

1. Set the device to the desired configuration.
2. Press **STO**. The STO button lights.
3. Press an input button (1 to 4).

The configuration is saved to the selected preset.

## Recalling a Preset

You can recall a stored preset from any of the 4 presets via the front panel input buttons (1 to 4).

**To recall a preset:**

1. Press **RCL**. The RCL button lights.
2. Press an input button (1 to 4) to select the desired configuration.

The selected preset is loaded.

---

## Switching an Input to an Output in the Matrix Mode

The **VSM-4x4x** matrix switcher mode is the default operation mode. Any of the four inputs can be switched to any of the four outputs. Switching is immediate and seamless (see [Connecting VSM-4x4x](#) on page 7) .

**To switch an input to an output via the front panel buttons:**

1. Select the Matrix operation mode.
2. Press an output and then an input to switch to the selected output.

An input is switched to the output.



---







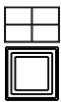
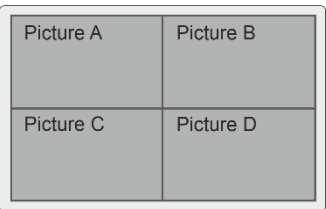

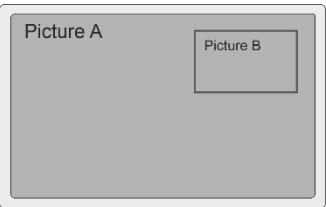

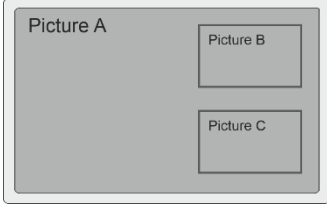
## Selecting a Multi-View Mode Configuration

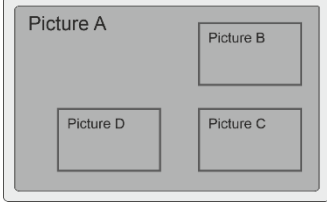
Set multi-view mode to multiple configurations and output each configuration identically to all the acceptors that are connected to the output. You can set the multi-view configuration via the front panel buttons and select the specific inputs for each configuration via the embedded web pages.

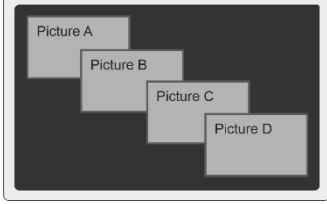
**To define the multi-view mode:**

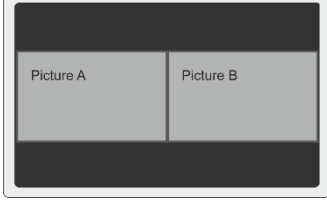
1. Connect the inputs and the outputs in the same way as in the matrix mode (see [Connecting VSM-4x4x](#) on page 7).
2. Press a multi-view front panel buttons to set the following multi-view modes (the input images on each display are defined as pictures):

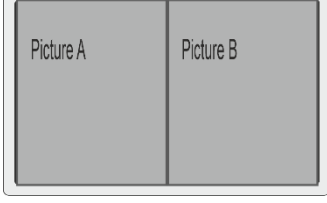
Press	Function Description	Result per Output
	QUAD – Displays any of the four inputs on one screen (each quarter of a screen can show any selected input) and outputs it identically to all four outputs (HDMI OUTPUT A to D).	
	PiP 1 – Picture A appears in the background and Picture B appears over picture A.	

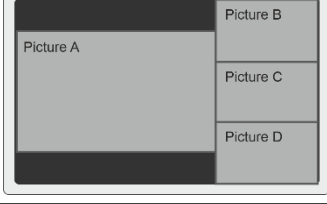
Press	Function Description	Result per Output
	PiP 2 – Picture A appears in the background, and Picture B and Picture C appear over picture A.	
	PiP 3 – Picture A appears in the background, and Picture B, Picture B and Picture D appear over picture A.	
	Stacked – Pictures A, B, C, and D appear stacked, overlapping one another (or as independent pictures if positioned in a manner where they do not overlap).	
	Side by side – Picture A and Picture B appear side by side, while maintaining aspect ratio.	
	Split – Picture A and Picture B appear side by side and fill the screen. Aspect ratio is not maintained.	
	PoP 3 – Pictures B, C and D appear on the right side of the screen and picture A fills the remaining empty area, while maintaining aspect ratio.	



The input images that appear in each picture are set as follows by default: Input 1 to Picture A, Input 2 to Picture B Input 3 to Picture C and Input 4 to Picture D. you can assign a different input to a picture via the embedded web pages (see [Operating and Controlling in the Multi-View Mode](#) on page 23).

## Selecting a Video Wall Configuration

The video wall mode lets you display the output on a set of four monitors / TV sets that are tiled together in a 2x2 or 1x4 setting to form one large display.

Each output shows part of the image as shown in the example in [Figure 6](#). In the video wall mode the audio of the selected input is routed to one of the outputs.

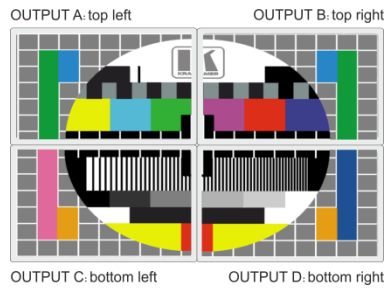

Figure 6: The VSM-4x4x Video Wall Operation Mode

## Connecting the VSM-4x4x in the Video Wall Operation Mode

Before configuring the video wall, you need to set up a video wall configuration.

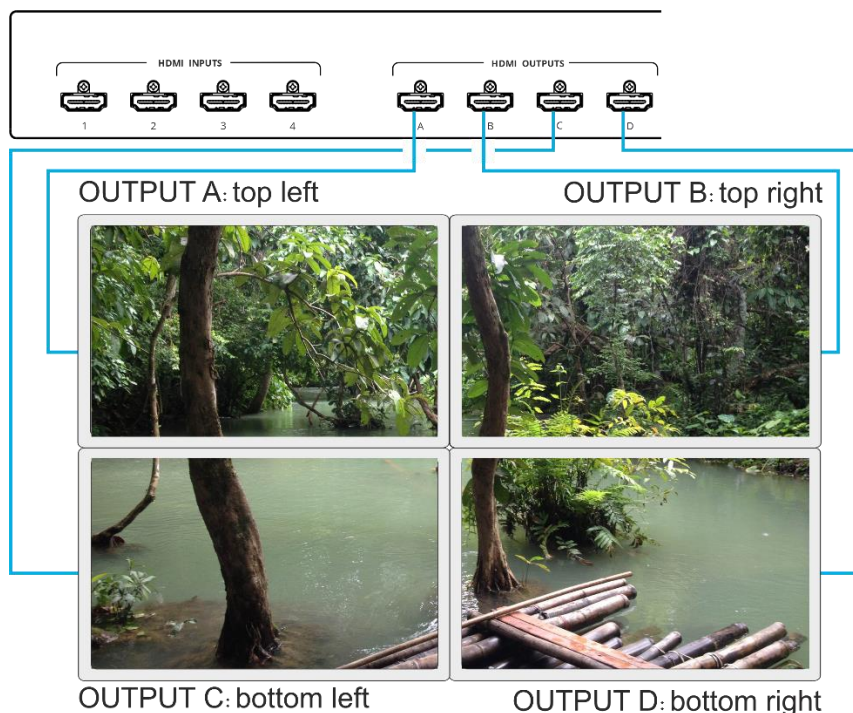

Figure 7: Connecting the VSM-4x4x in the Video Wall Operation Mode

### To set up a 2x2 video wall :

1. Connect up to 4 HDMI sources (for example, Blu-ray players) to the HDMI INPUT connectors (1 to 4), not shown in [Figure 7](#).
2. Connect the HDMI output connectors to the video wall screens. Connect the:
  - OUTPUT A connector to the top left screen.
  - OUTPUT B connector to the top right screen.
  - OUTPUT C connector to the bottom left screen.
  - OUTPUT D connector to the bottom right screen.

3. Connect the power.

4. Press  (VIDEO WALL 2x2 button).

Video Wall is configured.

# Operating via Ethernet

You can connect to **VSM-4x4x** via Ethernet using either of the following methods:

- Directly to the PC using a crossover cable (see [Connecting Ethernet Port Directly to a PC](#) on page 13).
- Via a network hub, switch, or router, using a straight-through cable (see [Connecting Ethernet Port via a Network Hub](#) on page 15).

**Note:** If you want to connect via a router and your IT system is based on IPv6, speak to your IT department for specific installation instructions.

## Connecting Ethernet Port Directly to a PC

You can connect the Ethernet port of **VSM-4x4x** directly to the Ethernet port on your PC using a crossover cable with RJ-45 connectors.



This type of connection is recommended for identifying **VSM-4x4x** with the factory configured default IP address.

After connecting **VSM-4x4x** to the Ethernet port, configure your PC as follows:

1. Click **Start > Control Panel > Network and Sharing Center**.
2. Click **Change Adapter Settings**.
3. Highlight the network adapter you want to use to connect to the device and click **Change settings of this connection**.

The Local Area Connection Properties window for the selected network adapter appears as shown in [Figure 8](#).

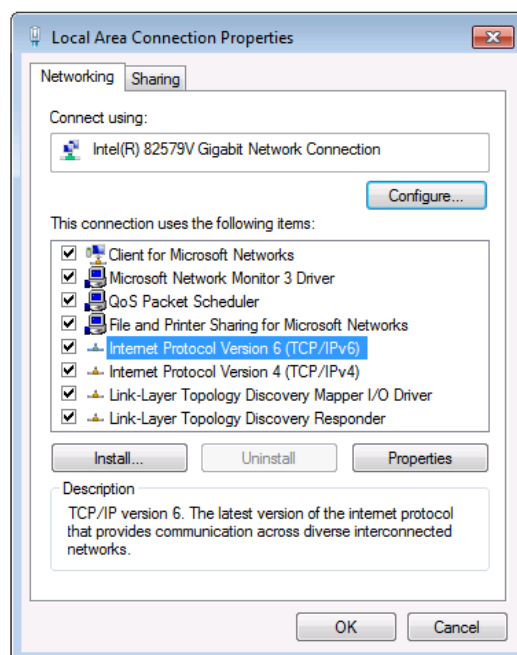

Figure 8: Local Area Connection Properties Window

4. Highlight either **Internet Protocol Version 6 (TCP/IPv6)** or **Internet Protocol Version 4 (TCP/IPv4)** depending on the requirements of your IT system.
5. Click **Properties**.  
The Internet Protocol Properties window relevant to your IT system appears as shown in [Figure 9](#) or [Figure 10](#).

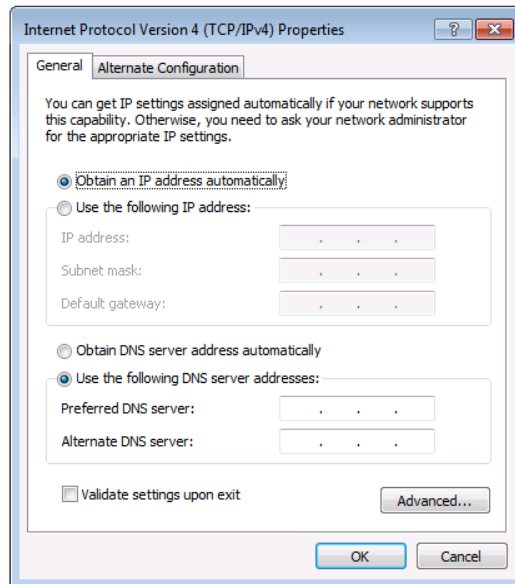

Figure 9: Internet Protocol Version 4 Properties Window

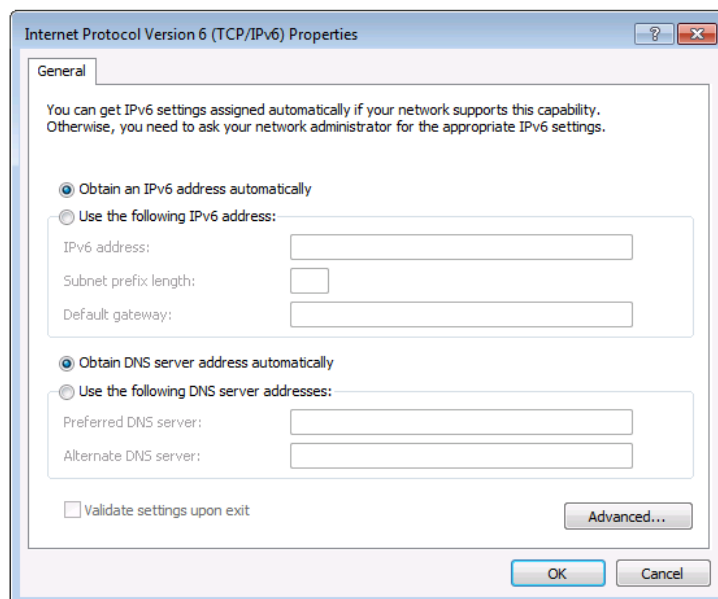

Figure 10: Internet Protocol Version 6 Properties Window

6. Select **Use the following IP Address** for static IP addressing and fill in the details as shown in [Figure 11](#).  
For TCP/IPv4 you can use any IP address in the range 192.168.1.1 to 192.168.1.255 (excluding 192.168.1.39) that is provided by your IT department.



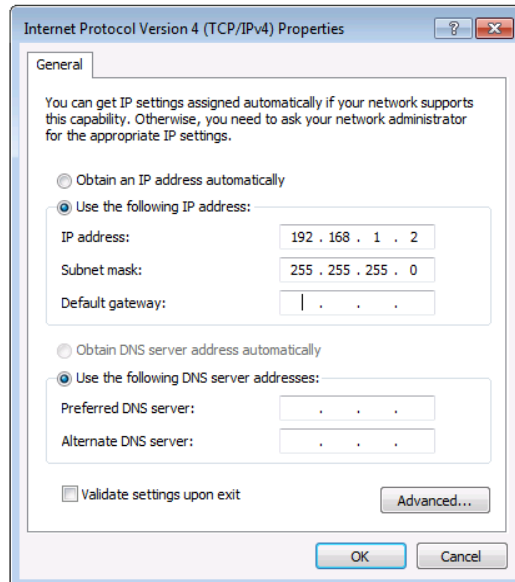

Figure 11: Internet Protocol Properties Window

7. Click **OK**.
8. Click **Close**.

## Connecting Ethernet Port via a Network Hub or Switch

You can connect the Ethernet port of **VSM-4x4x** to the Ethernet port on a network hub or using a straight-through cable with RJ-45 connectors.

## Configuring Ethernet Port

You can set the Ethernet parameters via the embedded Web pages.

# Using Embedded Web Pages

VSM-4x4x can be operated remotely using the embedded Web pages. The Web pages are accessed using a Web browser and an Ethernet connection.

Before attempting to connect:

- Perform the procedures in [Operating via Ethernet](#) on page [13](#).
- Ensure that your browser is supported.

The following operating systems and Web browsers are supported:

Operating Systems	Browser
Windows 7	Firefox
	Chrome
	Safari
Windows 10	Edge
	Firefox
	Chrome
Mac	Safari
iOS	Safari
Android	N/A



Some features might not be supported by some mobile device operating systems.

VSM-4x4x enables performing the following:

- [Defining AV Settings](#) on page [17](#).
- [Operating and Controlling in the Matrix Mode](#) on page [22](#).
- [Operating and Controlling in the Multi-View Mode](#) on page [23](#).
- [Operating and Controlling the Video Wall Mode](#) on page [40](#).
- [Managing EDID](#) on page [44](#).
- [Changing Device Name](#) on page [46](#).
- [Viewing the About Page](#) on page [51](#).

To browse the web pages:

1. Open your Internet browser.
2. Type the IP number of the device in the Address bar of your browser. For example, the default IP number:



The Controller application page appears.

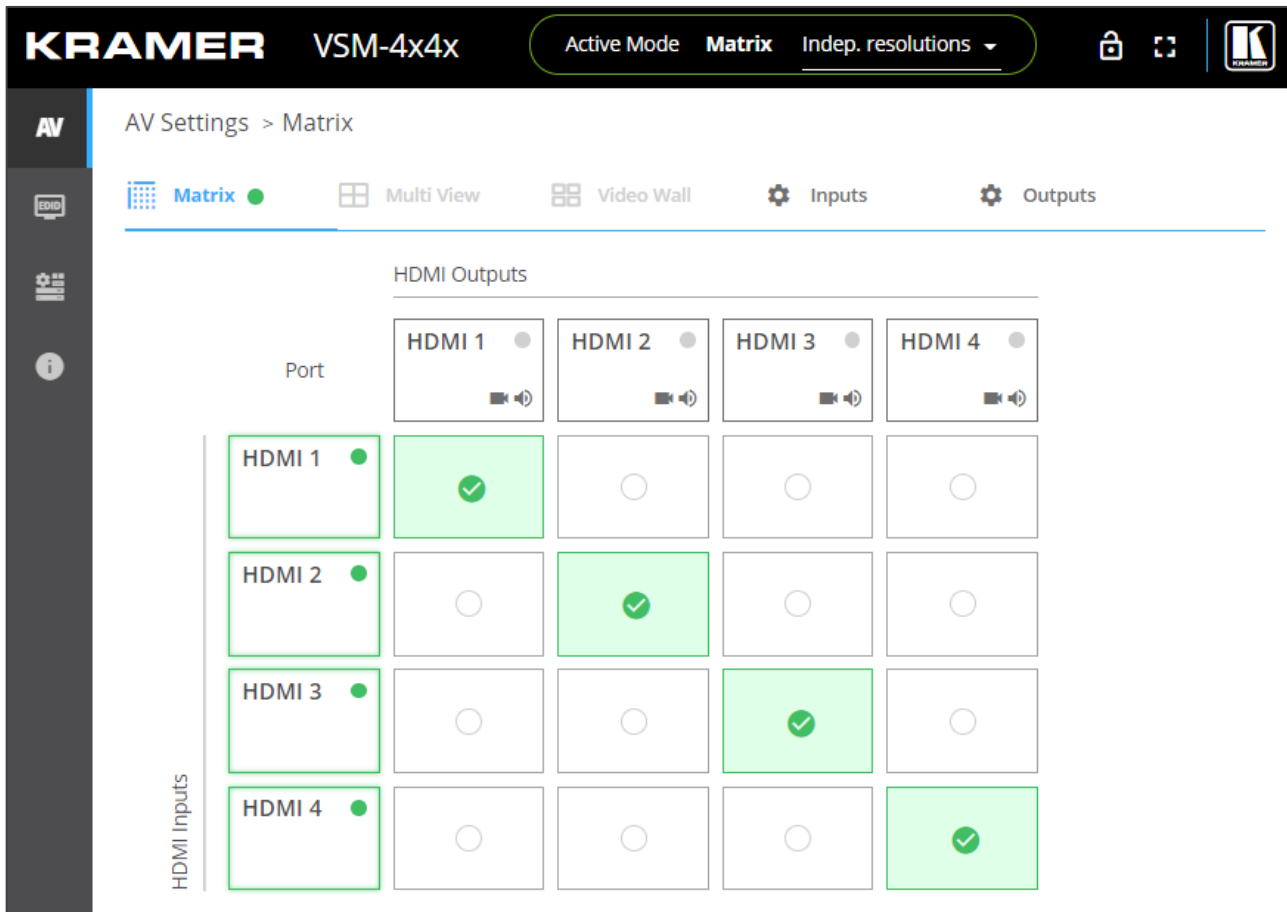

Figure 12: Controller Application Page with Navigation List on Left

3. Click the tabs on the left side of the screen to access the relevant web page.

## Defining AV Settings

VSM-4x4x has 3 major operation modes, Matrix, Multi-View and Video Wall which can be controlled via the embedded web pages. By default, the AV Settings page is set to the Matrix mode.

For each operation mode:

- [Selecting Device Operation Mode](#) on page [18](#).
- [Configuring the Layout](#) on page [19](#).
- [Adjusting Input Parameters](#) on page [20](#).
- [Adjusting Output Parameters](#) on page [21](#).

## Selecting Device Operation Mode

Use the webpage header to select the device active operation mode. When selecting

**To select the active mode configuration:**

1. Click **AV** on the Navigation List. The AV Settings page appears ([Figure 12](#)).
2. Next to Active Mode view the current operation mode.
3. Click the Active Mode drop-down box.

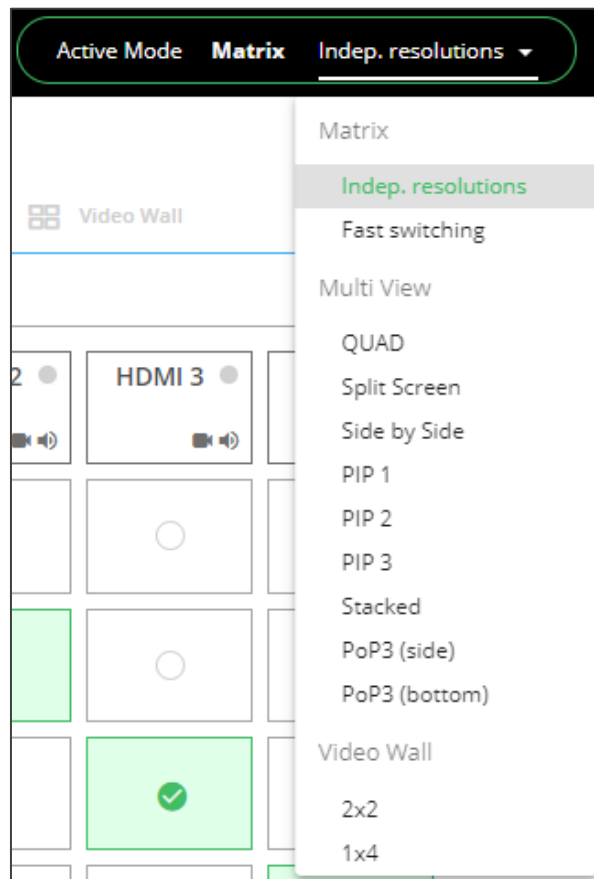

Figure 13: Selecting the Operation Mode

4. Select the desired configuration:
  - In the Matrix mode, select independent resolutions or fast switching (same output resolution for all the outputs).
  - In the Multi-View mode, select one of the listed configurations.
  - In the Video Wall mode, select 2x2 or 1x4.

The active operation mode is selected.

# Configuring the Layout

When in the matrix mode, the active mode is selected by the drop-down box. You can switch inputs to outputs and define the input and output settings. These settings are immediately reflected in the matrix mode. When in the multi-viewer and video wall mode you can configure a certain layout while a different layout is presented as the active mode.

For example, in the Multi-View mode the QUAD layout is selected and displayed on the outputs, but in the list of layouts on the left side, Split Screen is selected and can be configured. The unit remains in Multi-View mode though, and only when Split Screen is selected as the active mode will it appear on the displays.

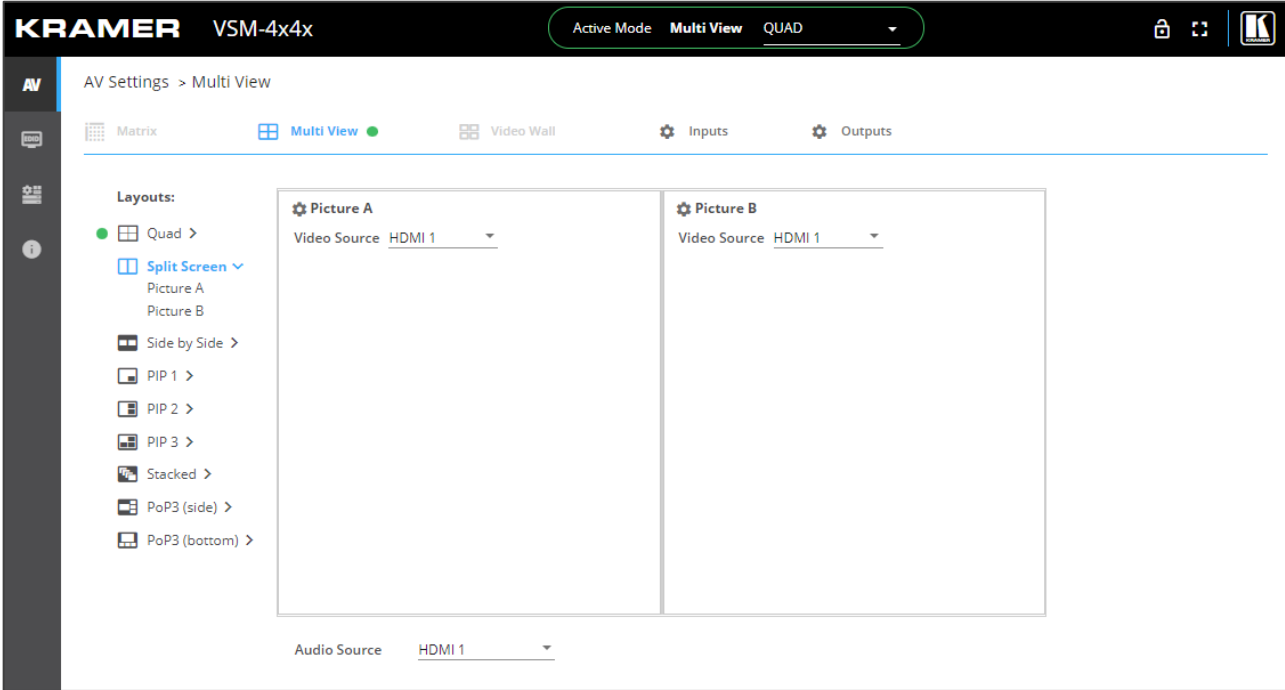

Figure 14: AV-Settings – QUAD Active Mode

## Adjusting Input Parameters

For each operation mode you can adjust the input settings. Not all parameters are available for each operation mode.

To adjust input parameters:

1. Click **AV** on the Navigation List. The AV Settings page appears ([Figure 12](#)).
2. Click **Inputs** tab.

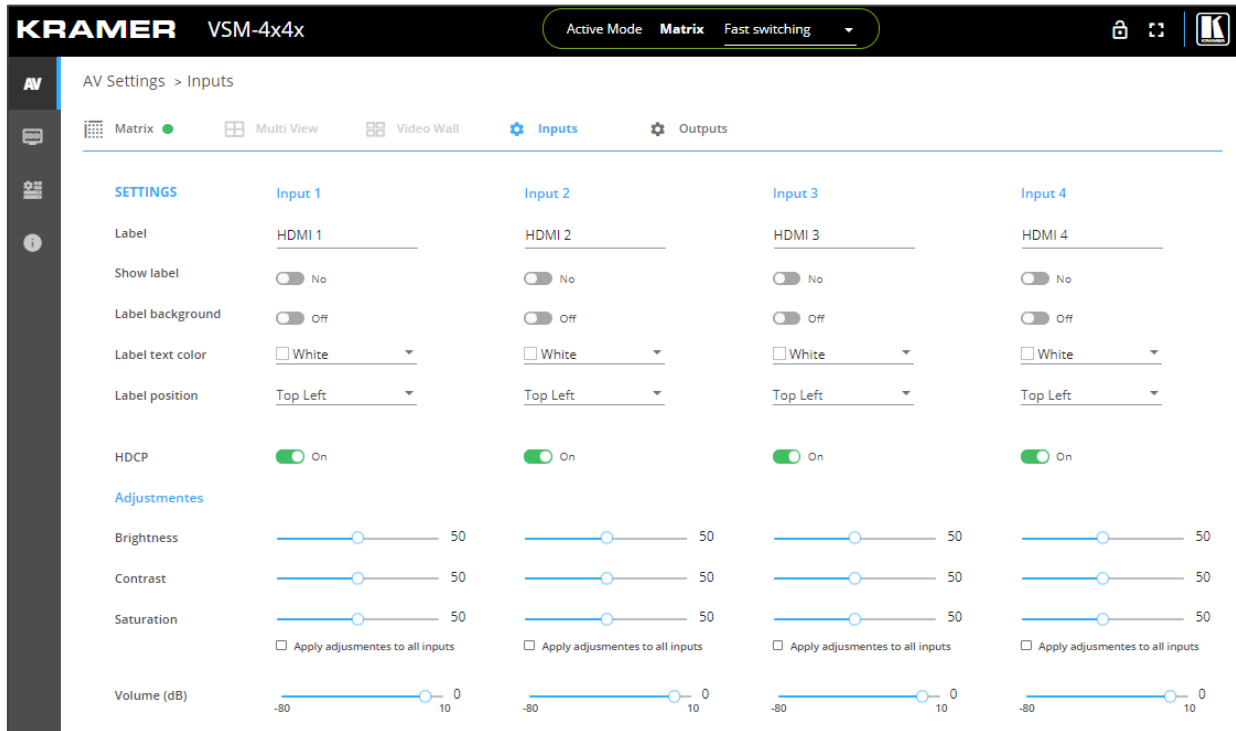

Figure 15: AV Settings – Inputs Tab

3. For each input define the label:
  - Change the input name.
  - Hide/show the label and/or label background.
  - Set the label text color.
  - Select label position on the display.
4. Set HDCP on each input On or Off.
5. Use the sliders, text box or arrows next to the sliders for each input to adjust the:
  - Brightness
  - Contrast
  - Saturation



If you need to make identical adjustments for all the inputs, check **Apply adjustments to all inputs** and adjust the video parameters on that input only. These parameters then apply to the other inputs.

Inputs are adjusted.

## Adjusting Output Parameters

For each operation mode you can adjust the output settings. Not all parameters are available for each operation mode.

To adjust output parameters:

1. Click **AV** on the Navigation List. The AV Settings page appears ([Figure 12](#)).
2. Click **Outputs** tab.

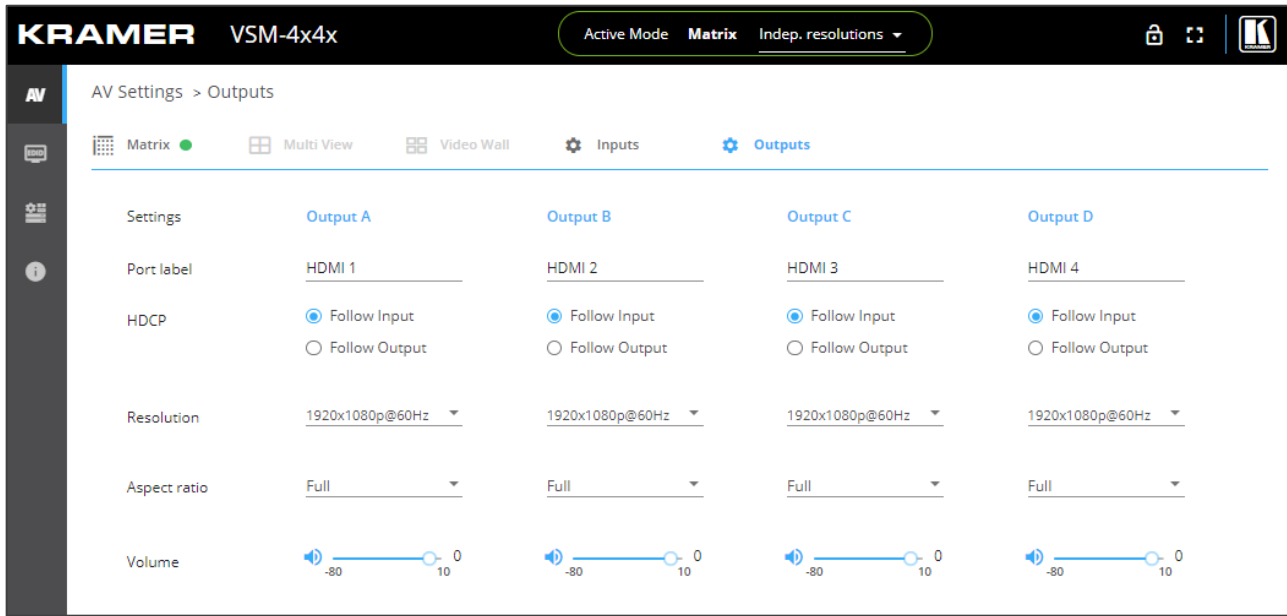

Figure 16: AV Settings – Outputs Tab

3. For each output:

- Change the name label.
- Set HDCP to Follow Input or Follow Output.
- Select the output resolution.



When Matrix configuration is set to Fast switching, the resolution and Aspect ratio are identical to all outputs and are set via Output A.

- Adjust the audio output volume.

Outputs are adjusted.

## Operating and Controlling in the Matrix Mode

VSM-4x4x matrix mode includes two configuration setups (selected via the Active Mode drop-down box, see [Selecting Device Operation](#) Mode on page 18):

- **Independent resolutions** – Allows to set the resolution and aspect ratio independently for each output.
- **Fast switching** – Output resolution and aspect ratio for each output are identical and are determined by output A.



Note that:

- The circle on each input button appears green when an active signal is present.
- The circle on each output appears green when a valid acceptor is connected to an output.

## Setting the inputs and outputs in the Matrix Mode

To set the inputs and outputs in the matrix mode see:

- [Adjusting Input Parameters](#) on page 20.
- [Adjusting Output Parameters](#) on page 21.



When in the Fast switching mode, the output resolutions and aspect ratio settings are identical for all the outputs and are set by Output A.

## Switching an Input to an Output

To switch an input to an output:

1. Click **AV** on the Navigation List. The AV Settings page appears ([Figure 12](#)).
2. Click a cross-point between an input and an output to switch an input to that output.
3. If required, do the following:
  - Click to mute the video output .
  - Click to adjust the output volume. The following window appears:

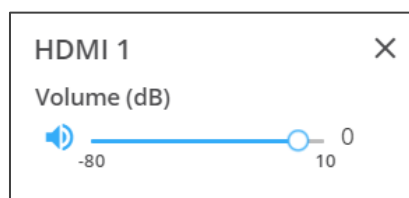

Figure 17: Setting the Output Volume

The inputs are switched to the outputs.



---

## Operating and Controlling in the Multi-View Mode

In the Multi-View mode, you can display several images in different configurations on one screen. To access multi-view configurations, see [Selecting Device Operation Mode](#) on page [18](#).

The multi-view mode enables performing the following actions:

- [Configuring the Quad Mode](#) on page [23](#).
- [Configuring the Split-Screen Mode](#) on page [26](#).
- [Operating and Configuring the Side-by-Side Mode](#) on page [29](#).
- [Operating and Configuring the PiP Mode](#) on page [32](#).
- [Operating and Configuring the Stacked Mode](#) on page [35](#).
- [Operating and Configuring the PoP Mode](#) on page [38](#).

### Configuring the Quad Mode

In the Quad mode, each screen is divided to 4 quarters, typically 1 for each input.

When in the QUAD mode, perform the following actions:

- [Configuring the QUAD Mode](#) on page [24](#).
- [Setting the Inputs and the Outputs in the Quad Mode](#) on page [25](#).
- [Defining QUAD Mode Pictures](#) on page [26](#).

### Configuring the QUAD Mode

To operate VSM-4x4x in the QUAD mode:

1. Click **AV** on the Navigation List. The AV Settings page appears (Figure 12).
2. Select QUAD configuration (see [Selecting Device Operation Mode](#) on page 18). The QUAD window appears:

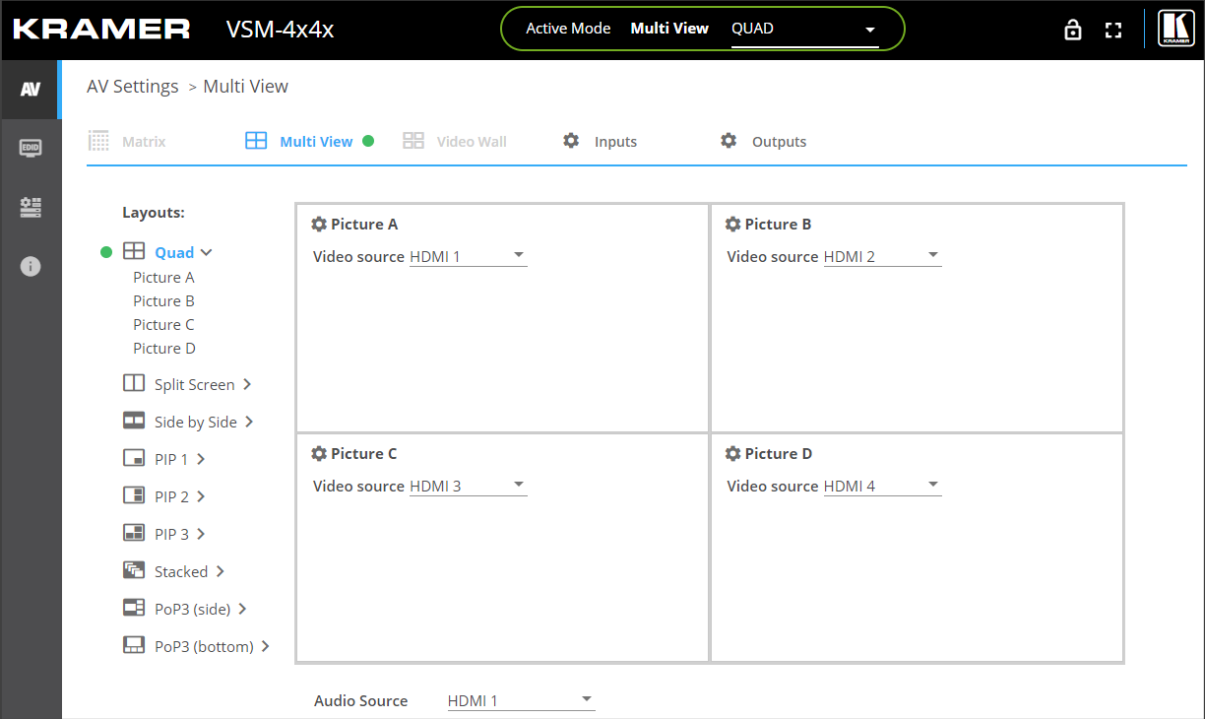

Figure 18: Multi-View Mode – QUAD Configuration

3. For each image (Picture A, B, C and D) select the video source.

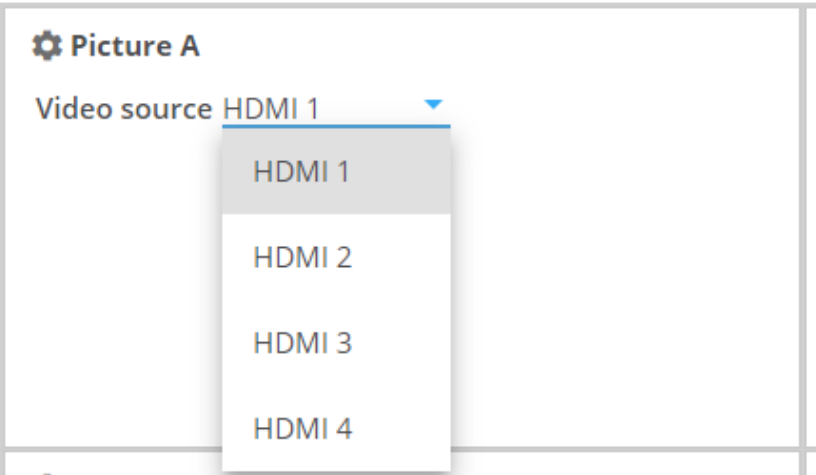

Figure 19: QUAD Configuration – Selecting the Video Source

4. From the Audio Source drop-down box, select the audio source.

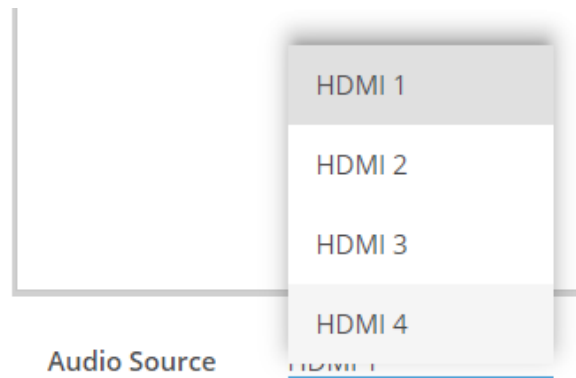

Figure 20: QUAD Configuration – Selecting the Audio Source

### Setting the Inputs and the Outputs in the Quad Mode

In the QUAD mode, click:

- **Inputs** (see [Adjusting Input Parameters](#) on page [20](#)) to adjust input parameters.
- **Outputs** (see [Adjusting Output Parameters](#) on page [21](#)) to adjust output parameters.



When adjusting the outputs, the output resolution is identical to all pictures and is set by the resolution in Output A.

## Defining QUAD Mode Pictures

You can configure each picture on the screen separately.

### To define a picture (for example, Picture A):

1. Click  next to Picture A or select Picture A from the QUAD Layouts list on the left. The Picture Settings window appears.

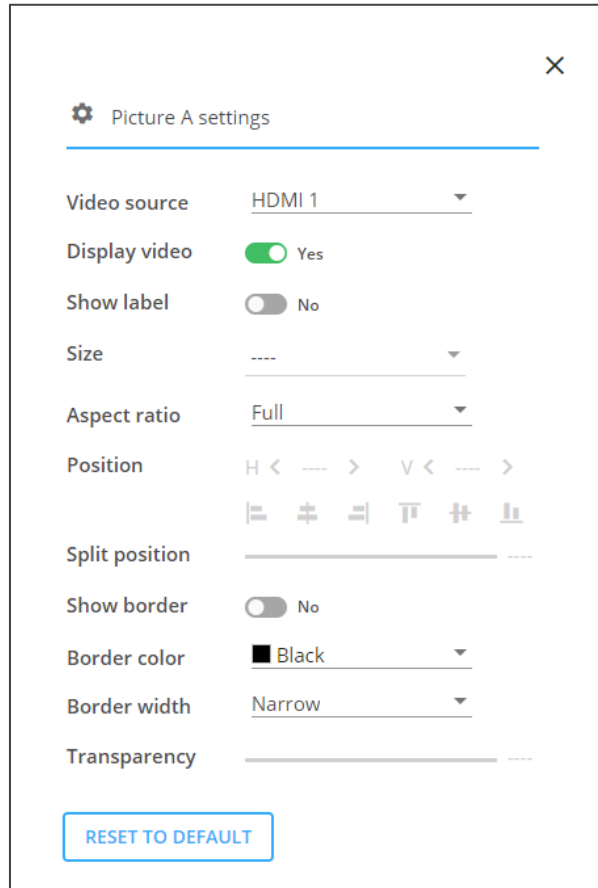

Figure 21: QUAD Mode – Picture Settings Window

2. Set the video source, enable/disable video, enable/disable label, set the aspect ratio, set border color and thickness and enable/disable the defined border.
3. Click **RESET TO DEFAULT** to reset settings to factory default.

Picture settings are defined.

## Configuring the Split-Screen Mode

In the Split Screen mode, the screen is divided in two, presenting to images on the screen.

Perform the following actions:

- [Operating in the Split Screen Mode](#) on page [27](#).
- [Setting the Inputs and the Outputs](#) on page [28](#).
- [Defining Split Screen Mode Pictures](#) on page [29](#).

## Operating in the Split Screen Mode

To operate VSM-4x4x in the Split Screen mode:

1. Click **AV** on the Navigation List. The AV Settings page appears (Figure 12).
2. Select Split Screen configuration (see [Selecting Device Operation Mode](#) on page 18). The QUAD window appears:

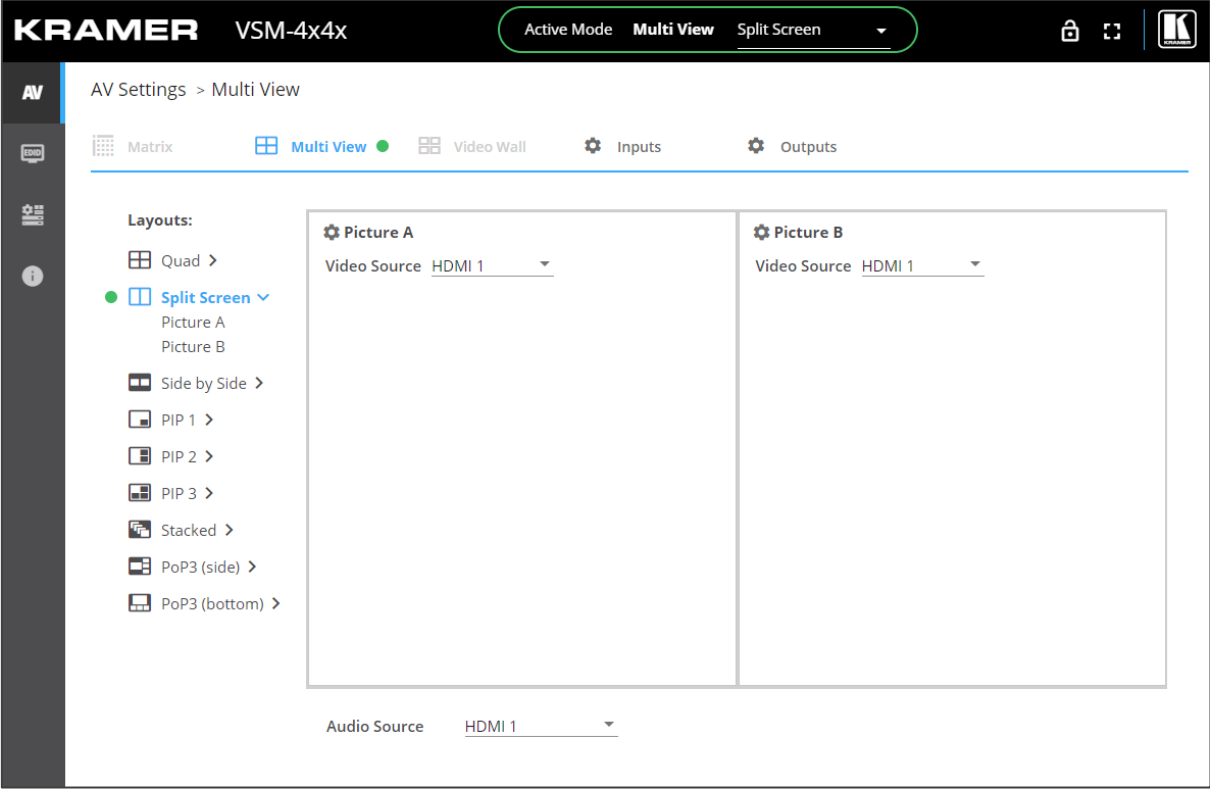

Figure 22: Multi-View Mode – Split Screen Configuration

3. For each image (Picture A and B) select the video source (in this example, both sources are HDMI 1, but any source can be selected).

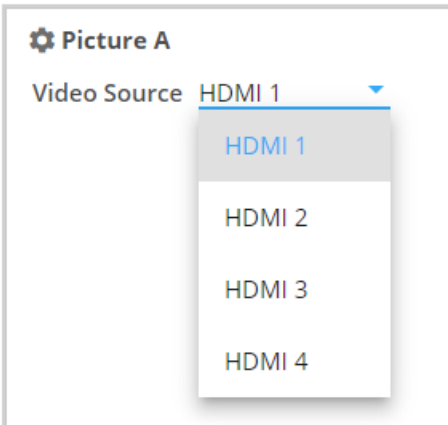

Figure 23: Split Screen Configuration – Selecting the Video Source

4. From the Audio Source drop-down box, select the audio source.

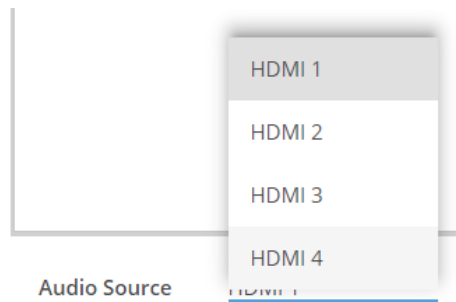

Figure 24: Split Screen Configuration – Selecting the Audio Source

## Setting the Inputs and the Outputs

In the Split Screen mode, click:

- **Inputs** (see [Adjusting Input Parameters](#) on page [20](#)) to adjust input parameters.
- **Outputs** (see [Adjusting Output Parameters](#) on page [21](#)) to adjust output parameters.



When adjusting the outputs, the output resolution is identical to all pictures and is set by the resolution in Output A.

## Defining Split Screen Mode Pictures

You can configure each picture on the screen separately.

### To define a picture (for example, Picture A):

1. Click  next to Picture A or select Picture A from the QUAD Layouts list on the left. The Picture Settings window appears.

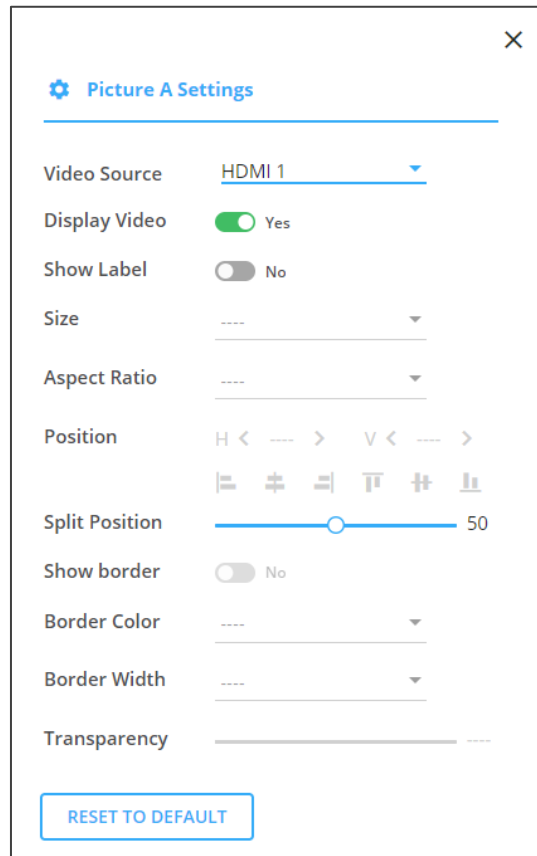

Figure 25: Split Screen Mode – Picture Settings Window

2. Set the video source, enable/disable video, enable/disable label and set the split position.
3. Click **RESET TO DEFAULT** to reset settings to factory default.

Picture settings are defined.

## Operating and Configuring the Side-by-Side Mode

In the Side-by-Side mode, two images are displayed on the screen.

Perform the following actions:

- [Operating in the Side-by-Side Mode](#) on page [30](#).
- [Setting the Inputs and the Outputs](#) on page [31](#).
- [Defining Side-by-Side Mode](#) on page [32](#).

### Operating in the Side-by-Side Mode

To operate VSM-4x4x in the Side-by-Side mode:

1. Click **AV** on the Navigation List. The AV Settings page appears (Figure 12).
2. Select Side-by-Side configuration (see [Selecting Device Operation Mode](#) on page 18). The Side-by-Side window appears.

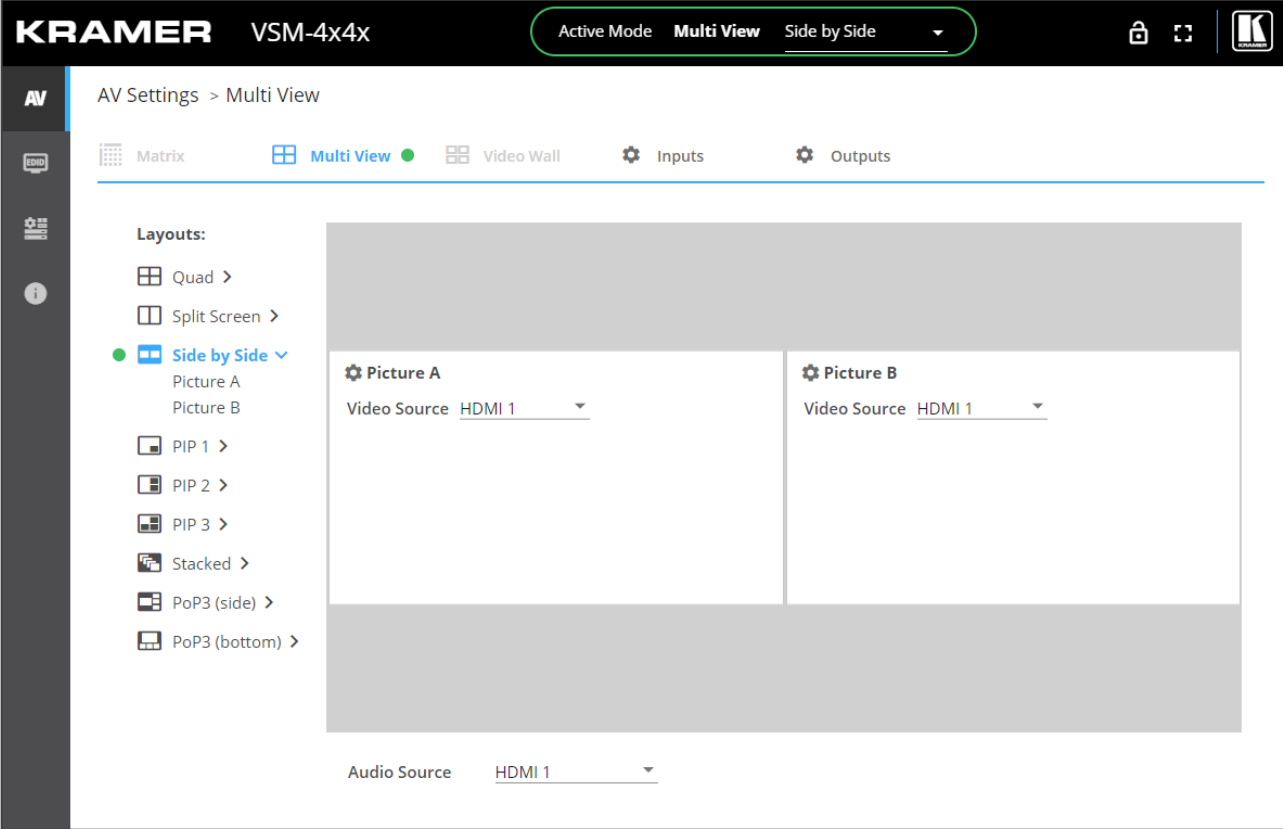

Figure 26: Multi-View Mode – Side-by-Side Screen Configuration

3. For each image (Picture A and B) select the video source.

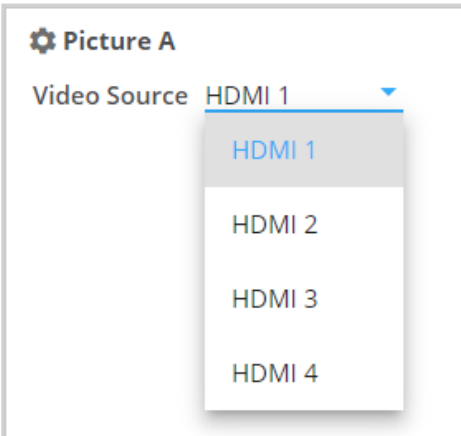

Figure 27: Split Screen Configuration – Selecting the Video Source



4. From the Audio Source drop-down box, select the audio source.

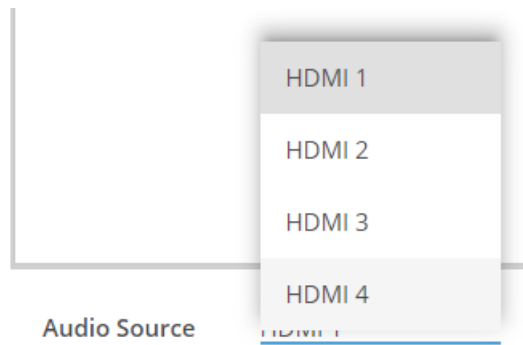

Figure 28: Split Screen Configuration – Selecting the Audio Source

## Setting the Inputs and the Outputs

In the Side-by-Side mode, click:

- **Inputs** (see [Adjusting Input Parameters](#) on page 20) to adjust input parameters.
- **Outputs** (see [Adjusting Output Parameters](#) on page 21) to adjust output parameters.



When adjusting the outputs, the output resolution is identical to all pictures and is set by the resolution in Output A.

## Defining Side-by-Side Mode

You can configure each picture on the screen separately.

### To define a picture (for example, Picture A):

1. Click  next to Picture A, or select Picture A from the QUAD Layouts list on the left. The Picture Settings window appears.

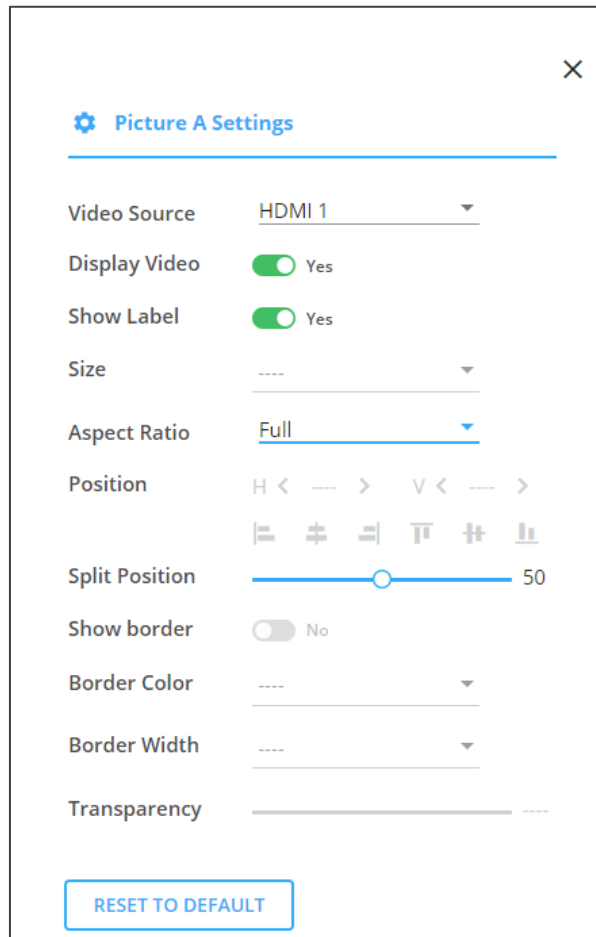

Figure 29: Split Screen Mode – Picture Settings Window

2. Set the video source, enable/disable video, enable/disable label, set the aspect ratio and set the split position.
3. Click **RESET TO DEFAULT** to reset settings to factory default.

Picture settings are defined.

## Operating and Configuring the PiP Mode

In the PiP (Picture-in-Picture) mode, several images are displayed over the background image. You can select up to 3 images over the background. This section describes the PiP 2 mode but applies to other PiP configurations.

Perform the following actions:

- [Operating in the PiP Mode](#) on page [33](#).
- [Setting the Inputs and the Outputs](#) on page [34](#).
- [Defining PiP Mode](#) Pictures on page [34](#).

## Operating in the PiP Mode

To operate VSM-4x4x in the PiP mode:

1. Click **AV** on the Navigation List. The AV Settings page appears (Figure 12).
2. Select any PiP configuration (see [Selecting Device Operation Mode](#) on page 18). The selected PiP configuration appears (PiP 2 in this example).

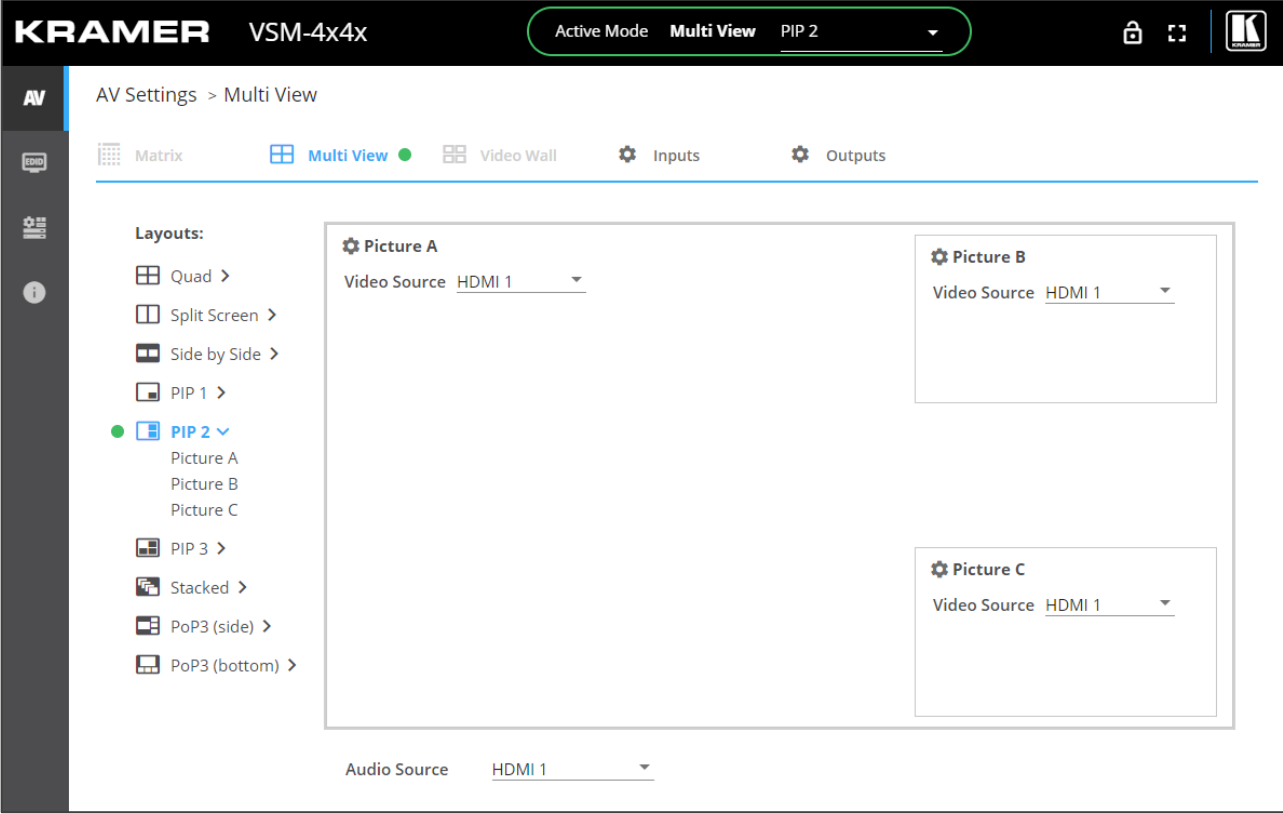

Figure 30: Multi-View Mode – Side-by-Side Screen Configuration



Picture A always represents the background image.

3. For each image (Picture A, B and C) select the video source.

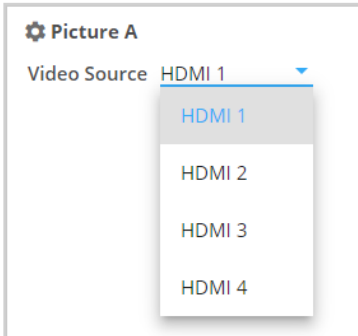

Figure 31: Split Screen Configuration – Selecting the Video Source

- From the Audio Source drop-down box, select the audio source.

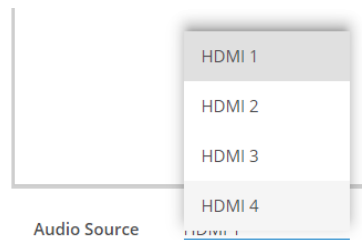



Figure 32: Split Screen Configuration – Selecting the Audio Source

## Setting the Inputs and the Outputs

In the PiP mode, click:

- **Inputs** (see [Adjusting Input Parameters](#) on page 20) to adjust input parameters.
- **Outputs** (see [Adjusting Output Parameters](#) on page 21) to adjust output parameters.

 When adjusting the outputs, the output resolution is identical to all pictures and is set by the resolution in Output A.

## Defining PiP Mode Pictures

You can configure each picture on the screen separately.

 The background image and each PiP image have different settings.

## To define the background picture (Picture A) and a PiP picture (for example, Picture B):

1. Click  next to Picture A/Picture B or select Picture A/Picture B from the PiP Layouts list on the left. The Picture Settings window appears.

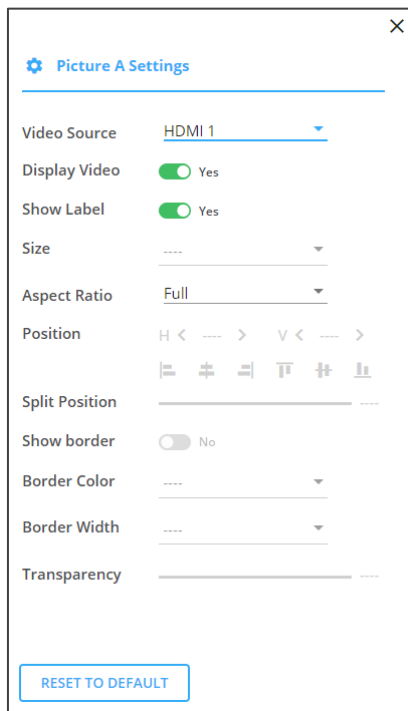

Figure 33: PiP Mode – Background (Picture A) Settings Window

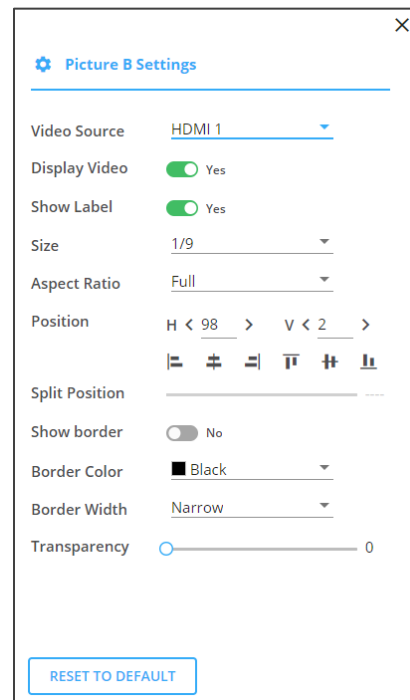

Figure 34: PiP Mode – PiP (Picture B) Settings Window

2. Define window settings:
  - Background image: set the video source, enable/disable video, enable/disable label and set the aspect ratio.
  - PiP image: set the video source, enable/disable video, set the aspect ratio, enable/disable label, set the window size, position and alignment, set border color and width, and set the transparency of the window.
3. Click **RESET TO DEFAULT** to reset settings to factory default.

Picture settings are defined.

## Operating and Configuring the Stacked Mode

In the stacked mode, all 4 images are overlapping.

Perform the following actions:

- [Operating in the Stacked Mode](#) on page [36](#).
- [Setting the Inputs and the Outputs](#) on page [37](#).
- [Defining Stacked Mode Pictures](#) on page [37](#).

### Operating in the Stacked Mode

To operate VSM-4x4x in the Stacked mode:

1. Click **AV** on the Navigation List. The AV Settings page appears (Figure 12).
2. Select Stacked configuration (see [Selecting Device Operation Mode](#) on page 18). The selected Stacked configuration appears:

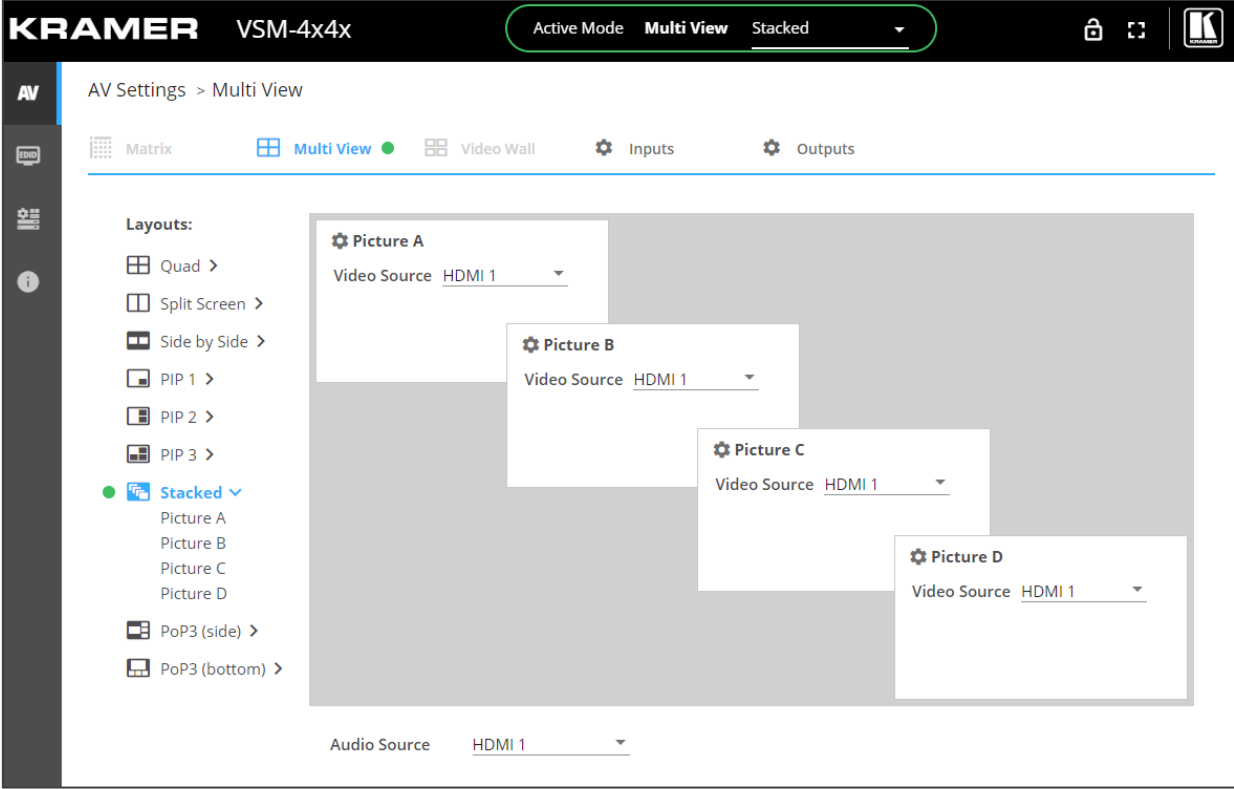

Figure 35: Multi-View Mode – Stacked Screen Configuration

3. For each image (Picture A, B, C and D) select the video source.

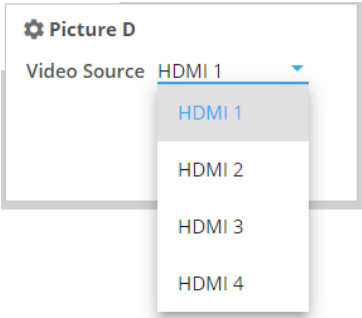

Figure 36: Stacked Configuration – Selecting the Video Source

4. From the Audio Source drop-down box, select the audio source.

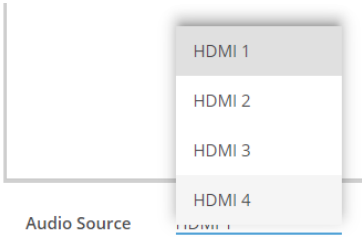

Figure 37: Split Screen Configuration – Selecting the Audio Source

## Setting the Inputs and the Outputs

In the Stacked mode, click:

- **Inputs** (see [Adjusting Input Parameters](#) on page 20) to adjust input parameters.
- **Outputs** (see [Adjusting Output Parameters](#) on page 21) to adjust output parameters.



When adjusting the outputs, the output resolution is identical to all pictures and is set by the resolution in Output A.

## Defining Stacked Mode Pictures

You can configure each picture on the screen separately.

To define the picture:

1. Click next to a Picture or select a Picture A/Picture B/Picture C/Picture D from the Stacked Layouts list on the left. The Picture Settings window appears.

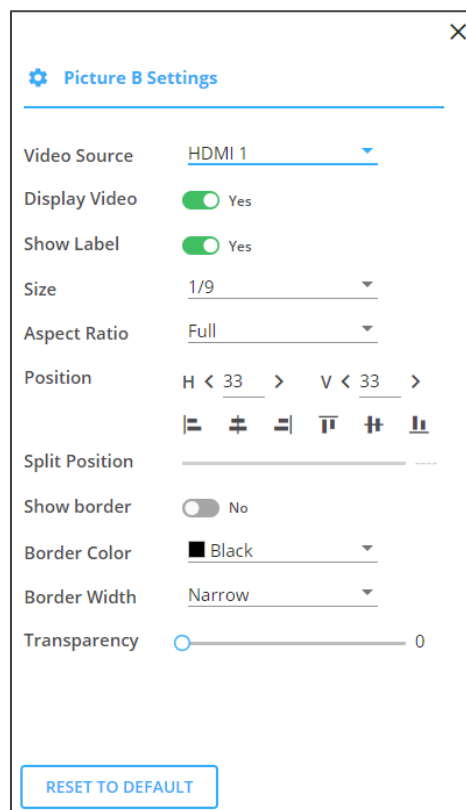

Figure 38: Stacked Mode – Stacked Settings Window

2. Set the video source, enable/disable video, set the aspect ratio, enable/disable label, set the window size, position and alignment, set border color and width, and set the transparency of the window.
3. Click **RESET TO DEFAULT** to reset settings to factory default.

Picture settings are defined.

## Operating and Configuring the PoP Mode

In the PoP mode, one large window and 3 other smaller images, either on the side (side) or on the lower area of the screen (bottom) are displayed, while maintaining aspect ratio.

Perform the following actions:

- [Operating in the PoP Mode](#) on page [38](#).
- [Setting the Inputs and the Outputs](#) on page [39](#).
- [Defining PoP Mode Pictures](#) on page [40](#).

### Operating in the PoP Mode

To operate VSM-4x4x in the PoP mode (for example, side):

1. Click **AV** on the Navigation List. The AV Settings page appears ([Figure 12](#)).
2. Select PoP configuration (see [Selecting Device Operation Mode](#) on page [18](#)). The PoP (side) window appears.

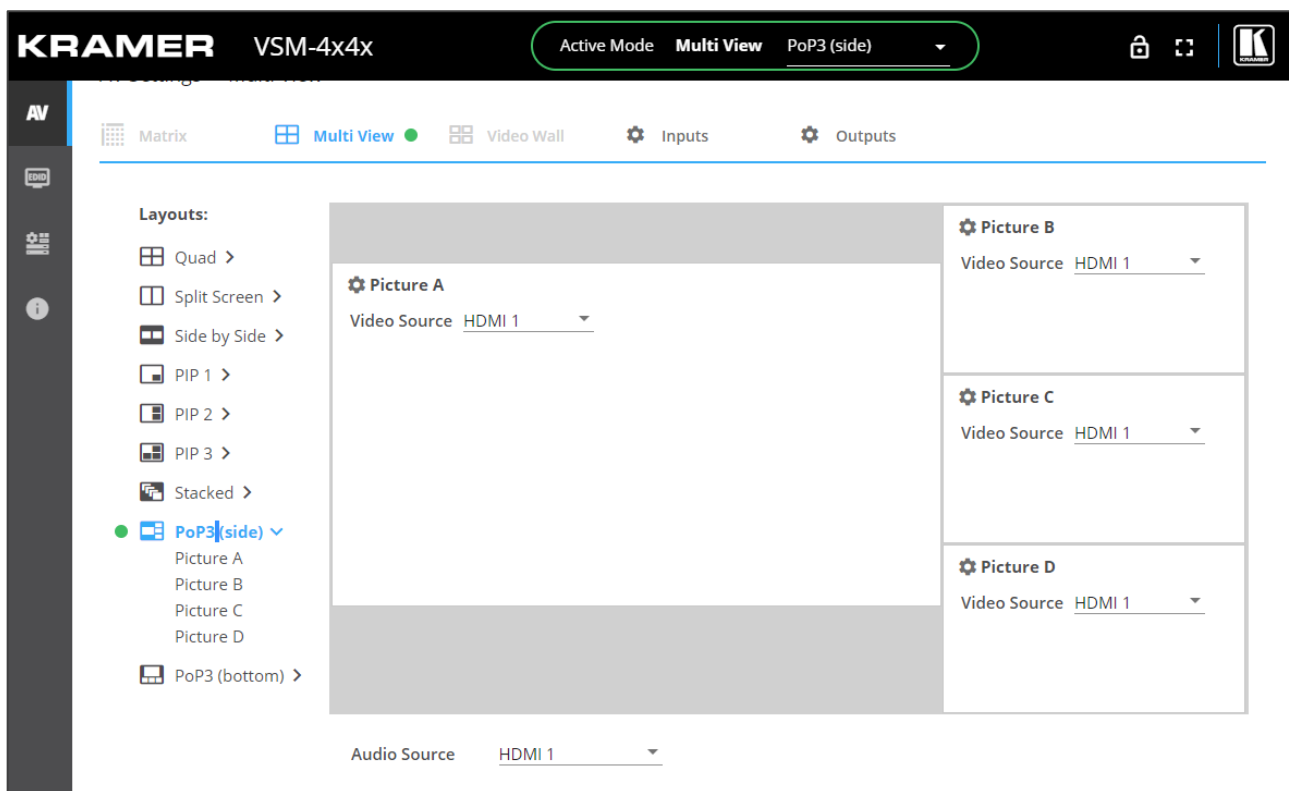

Figure 39: Multi View Mode – PoP Screen Configuration



3. For each image (Picture A, B, C and D) select the video source.

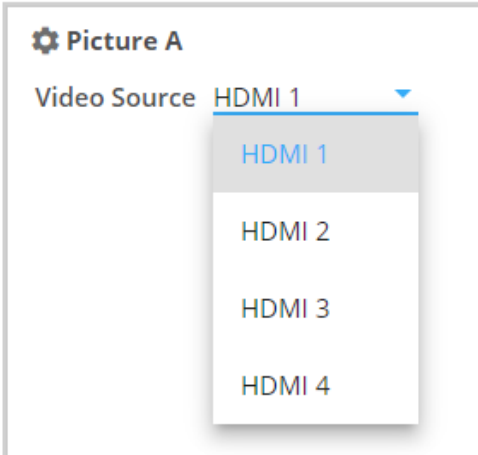

Figure 40: PoP Configuration – Selecting the Video Source

4. From the Audio Source drop-down box, select the audio source.

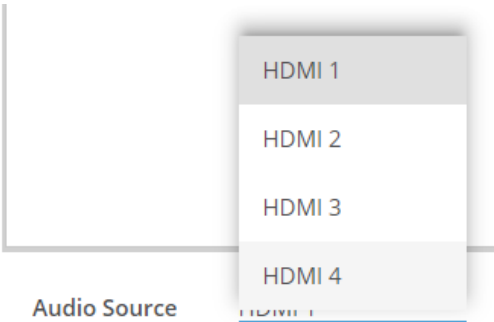



Figure 41: PoP Configuration – Selecting the Audio Source

### Setting the Inputs and the Outputs

In the PoP mode, click:

- **Inputs** (see [Adjusting Input Parameters](#) on page 20) to adjust input parameters.
- **Outputs** (see [Adjusting Output Parameters](#) on page 21) to adjust output parameters.

 When adjusting the outputs, the output resolution is identical to all pictures and is set by the resolution in Output A.

## Defining PoP Mode Pictures

You can configure each picture on the screen separately.

### To define a picture (for example, Picture A):

1. Click  next to Picture A, or select Picture A from the PoP Layouts list on the left. The Picture Settings window appears.

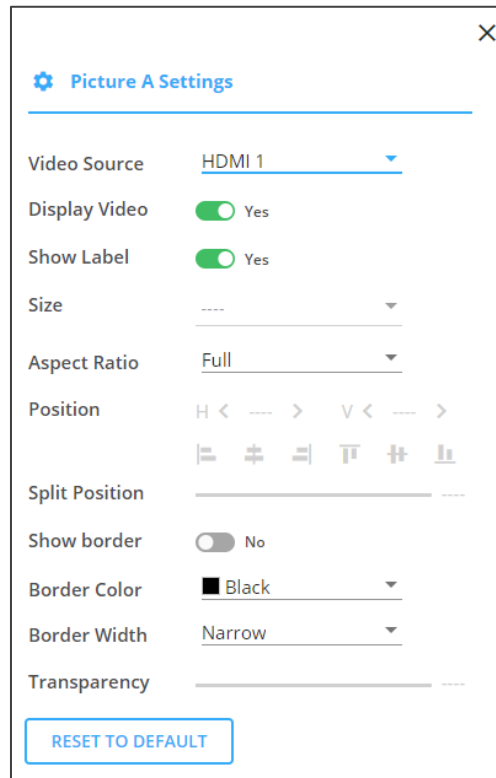

Figure 42: Split Screen Mode – Picture Settings Window

2. Set the video source, enable/disable video, enable/disable label, set the aspect ratio and set the border color and width.
3. Click **RESET TO DEFAULT** to reset settings to factory default.

Picture settings are defined.

---

## Operating and Controlling the Video Wall Mode

The Video Wall mode includes 2x2 and 1x4 configurations. To access Multi-View configurations, see [Selecting Device Operation Mode](#) on page [18](#).

In the 2x2 mode, one large window and 3 other smaller images, either on the side (side) or on the lower area of the screen (bottom) are displayed, while maintaining aspect ratio.

Perform the following actions:

- [Operating in the 2x2 Video Wall Mode](#) on page [41](#).
- [Operating in the 1x4 Video Wall Mode](#) on page [42](#).
- [Adjusting Bezel Correction](#) on page [43](#).

# Operating in the 2x2 Video Wall Mode

To operate VSM-4x4x in the 2x2 video wall mode:

- 1. Click **AV** on the Navigation List. The AV Settings page appears (Figure 12).
- 2. Select 2x2 configuration (see [Selecting Device Operation Mode](#) on page 18). The 2x2 window appears:

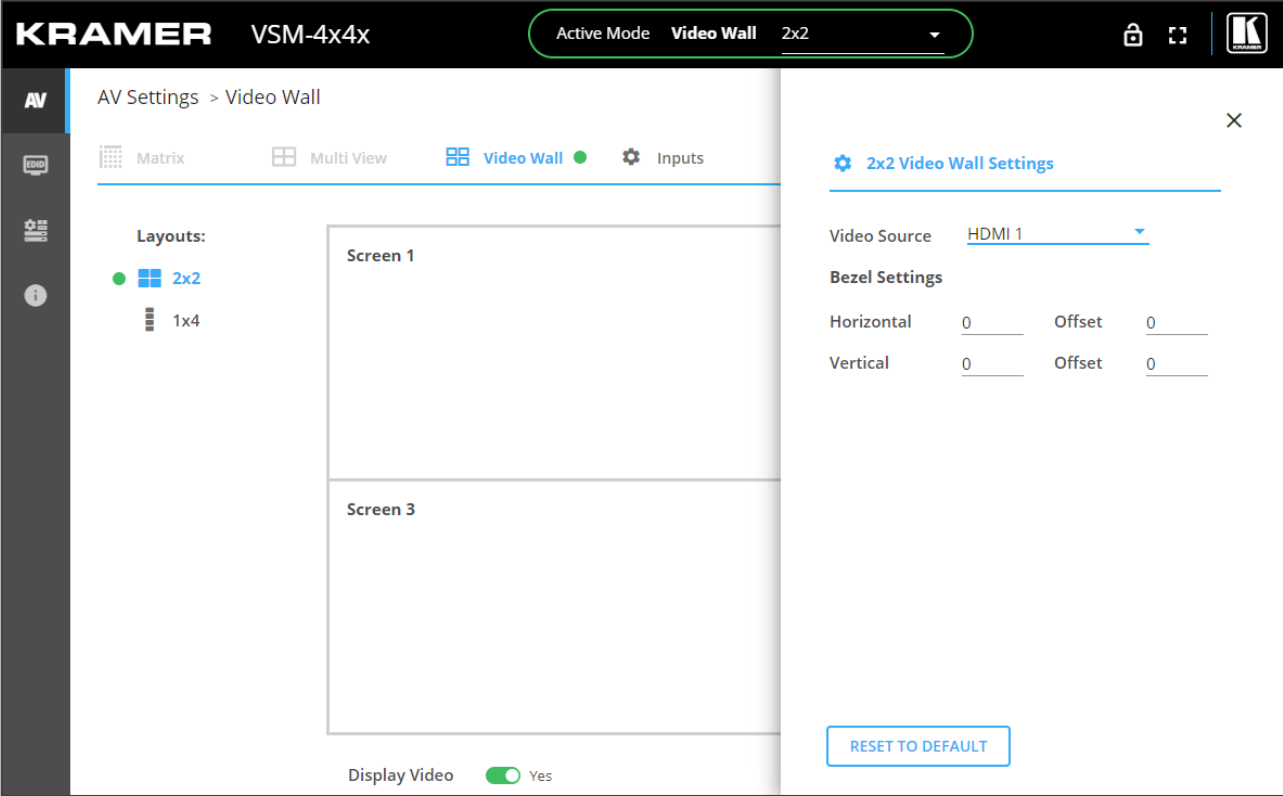

Figure 43: Video Wall Mode – 2x2 Video Wall Configuration

- 3. In the Settings window, select the input source.

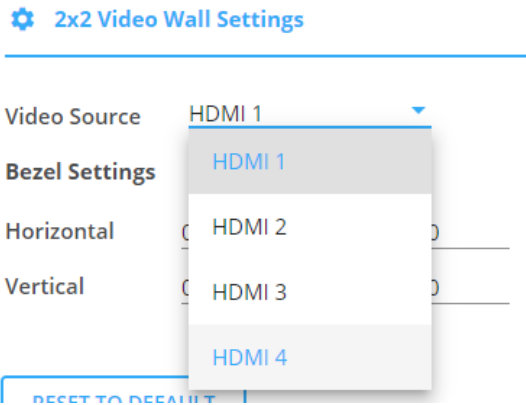

Figure 44: PoP Configuration – Selecting the Video Source

- 4. Define Bezel Settings.
  - 5. Click **RESET TO DEFAULT** to reset settings to factory default.
- Video wall is defined.

## Operating in the 1x4 Video Wall Mode

To operate VSM-4x4x in the 2x2 video wall mode:

1. Click **AV** on the Navigation List. The AV Settings page appears ([Figure 12](#)).
2. Select 2x2 configuration (see [Selecting Device Operation Mode](#) on page 18). The 2x2 window appears:

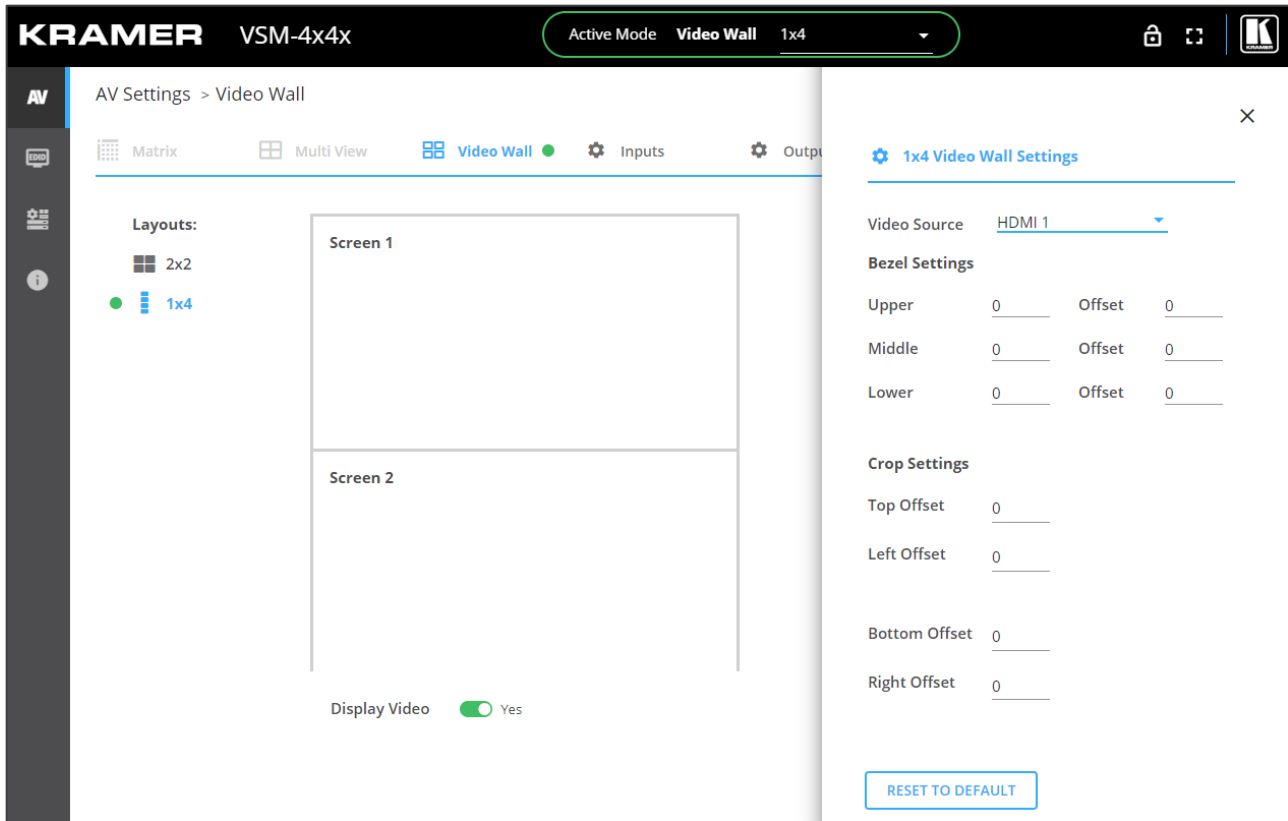

Figure 45: Video Wall Mode – 2x2 Video Wall Configuration

3. In the Settings window, select the input source.

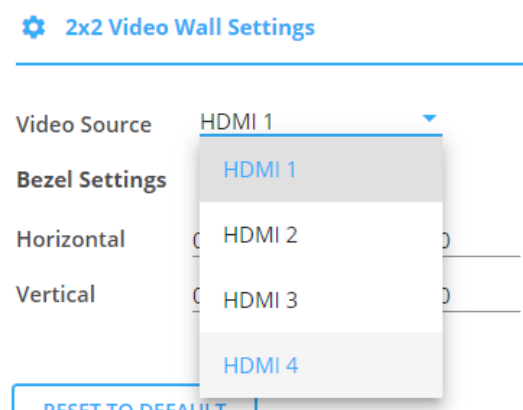

Figure 46: PoP Configuration – Selecting the Video Source

4. Define Bezel Settings (see [Adjusting Bezel Correction](#) on page 43).
5. Crop the image as needed.
6. Click **RESET TO DEFAULT** to reset settings to factory default.

Video wall is defined.

## Setting the Inputs and the Outputs

In the Video Wall mode click:

- **Inputs** (see [Adjusting Input Parameters](#) on page 20) to adjust input parameters.
- **Outputs** (see [Adjusting Output Parameters](#) on page 21) to adjust output parameters.



When adjusting the outputs, the output resolution is identical to all pictures and is set by the resolution in Output A.

## Adjusting Bezel Correction

Bezel correction makes up for the rims around the displays used for creating the video wall, thus creating one smooth picture. In the example in [Figure 47](#) the top photo shows the video wall before bezel connection and the lower photo shows the corrected image on the video wall.

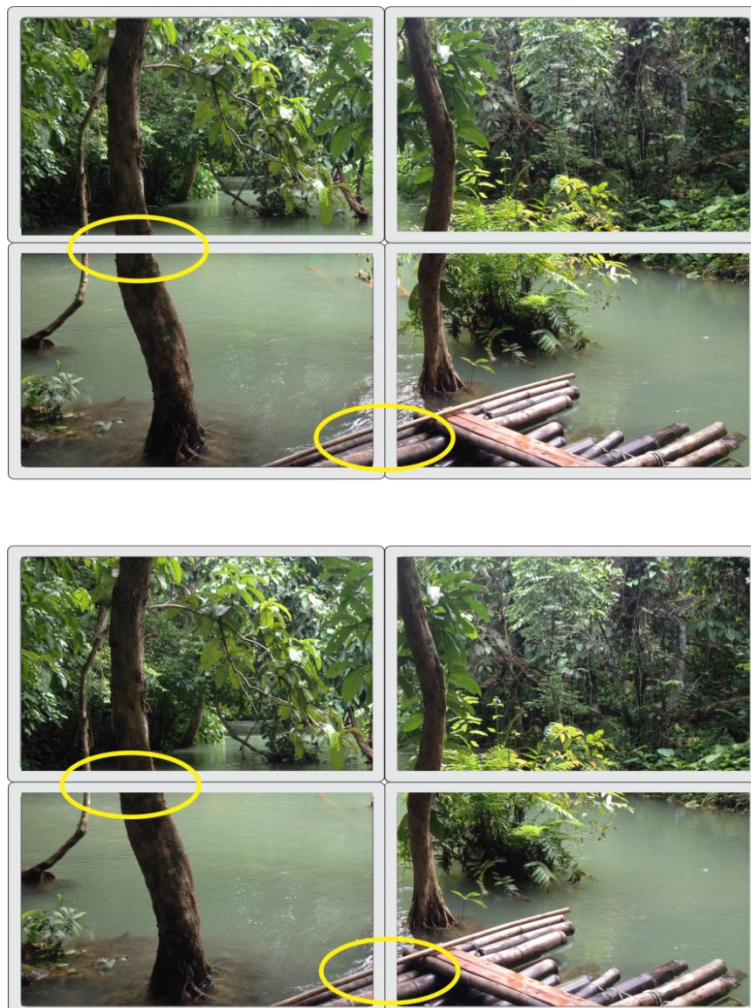

Figure 47: VSM-4x4x Bezel Correction

# Managing EDID

VSM-4x4x enables you to individually configure and manage EDID settings for each of the 4 inputs.

To manage EDID:

- 1. Click **EDID** on the Navigation List. The EDID page appears.

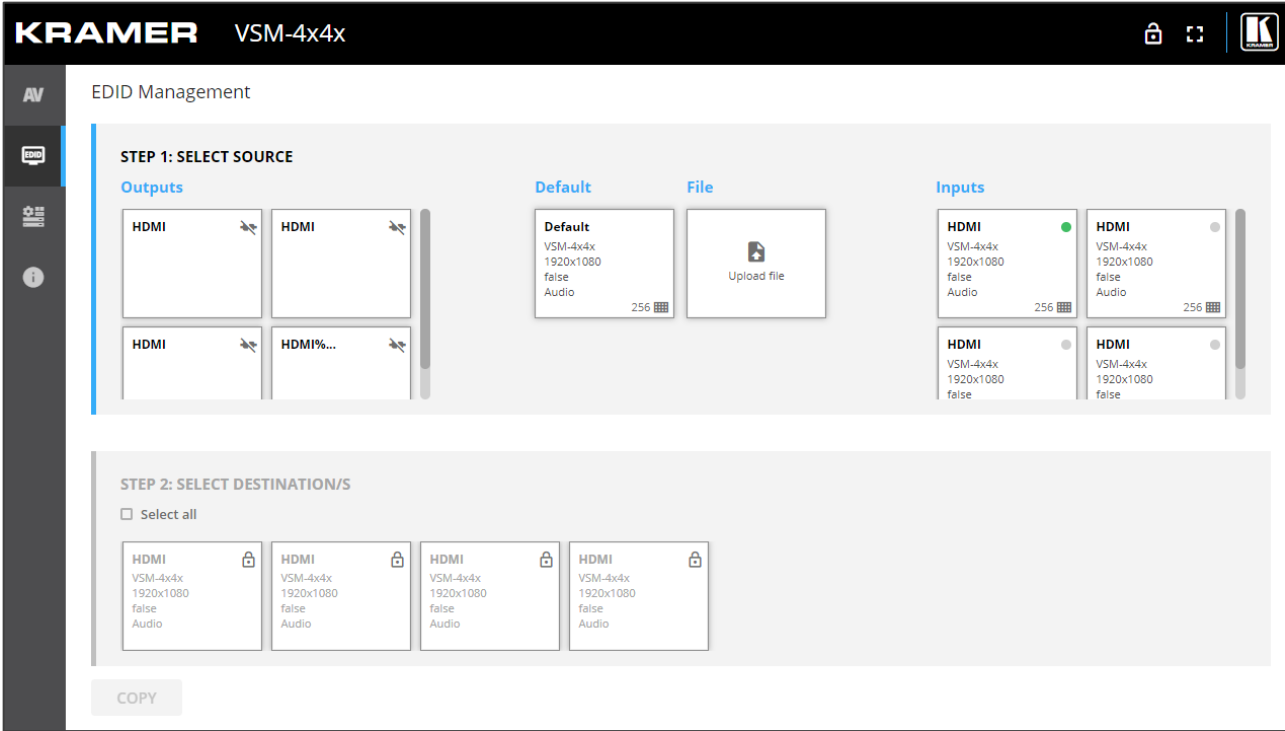

Figure 48: EDID Management Page

- 2. Under **STEP 1: SELECT SOURCE**, click the required EDID source from the outputs, inputs, default EDID or an uploaded EDID configuration file (for example, the default EDID file).

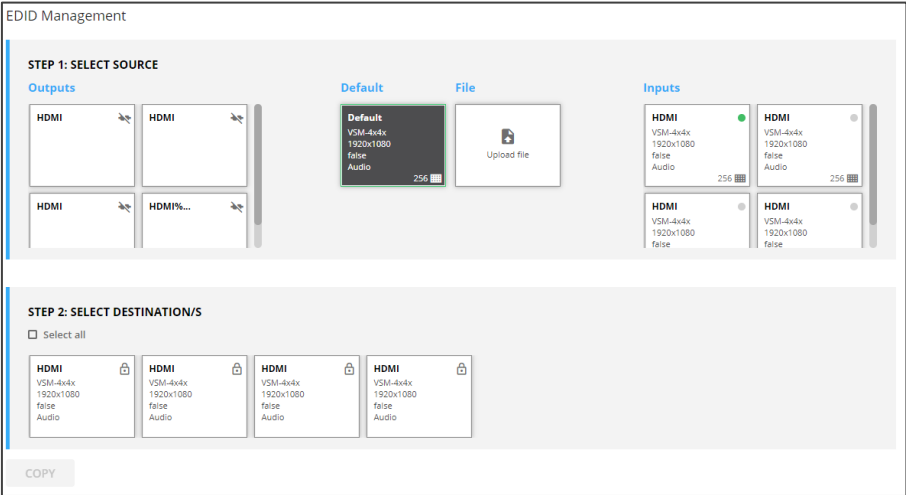

Figure 49: Selecting the EDID Source

- Under **STEP 2: SELECT DESTINATIONS**, click the input/s to copy the selected EDID to. The Copy button is enabled.

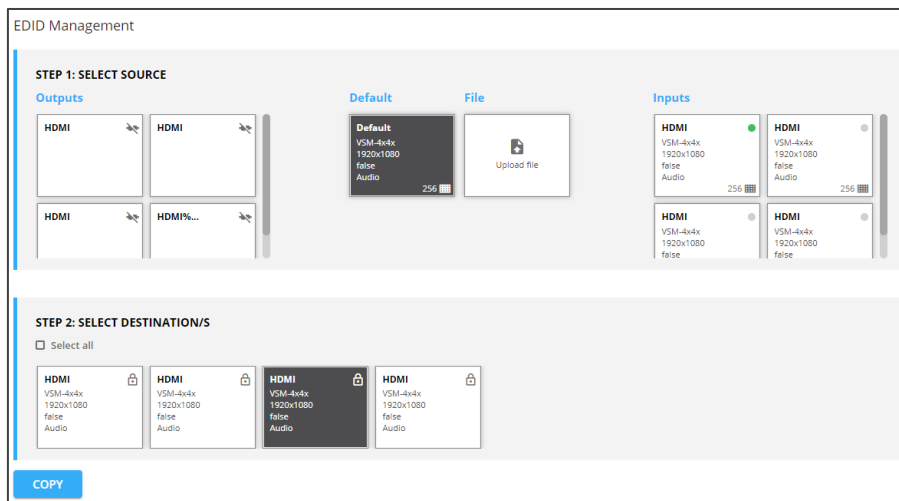

Figure 50: Selecting EDID Input Destinations

- Click **COPY**. The following message appears.

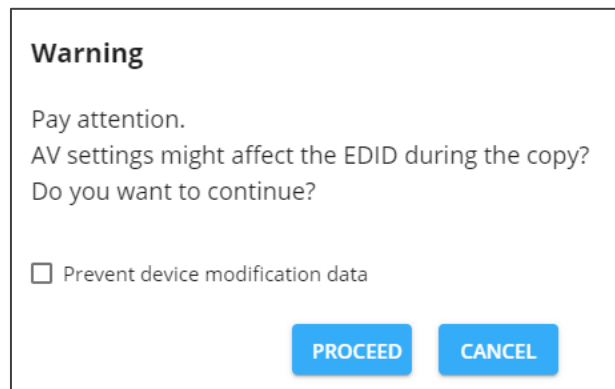

Figure 51: EDID Warning

If you do not want AV settings to change, check “Prevent device modification data”.

- Click **PROCEED**. After EDID is copied, a success message appears. EDID is copied to the selected input/s.

---

## Defining General Settings

VSM-4x4x enables performing the following actions via the General Settings tab:

- [Changing Device Name](#) on page [46](#).
- [Upgrading Firmware](#) on page [46](#).
- [Restarting and Resetting the Device](#) on page [47](#).

## Changing Device Name

You can change the **VSM-4x4x** name,

To change the device name:

1. In the Navigation Pane, click **Device Settings**. The General tab in the Device Settings page appears.

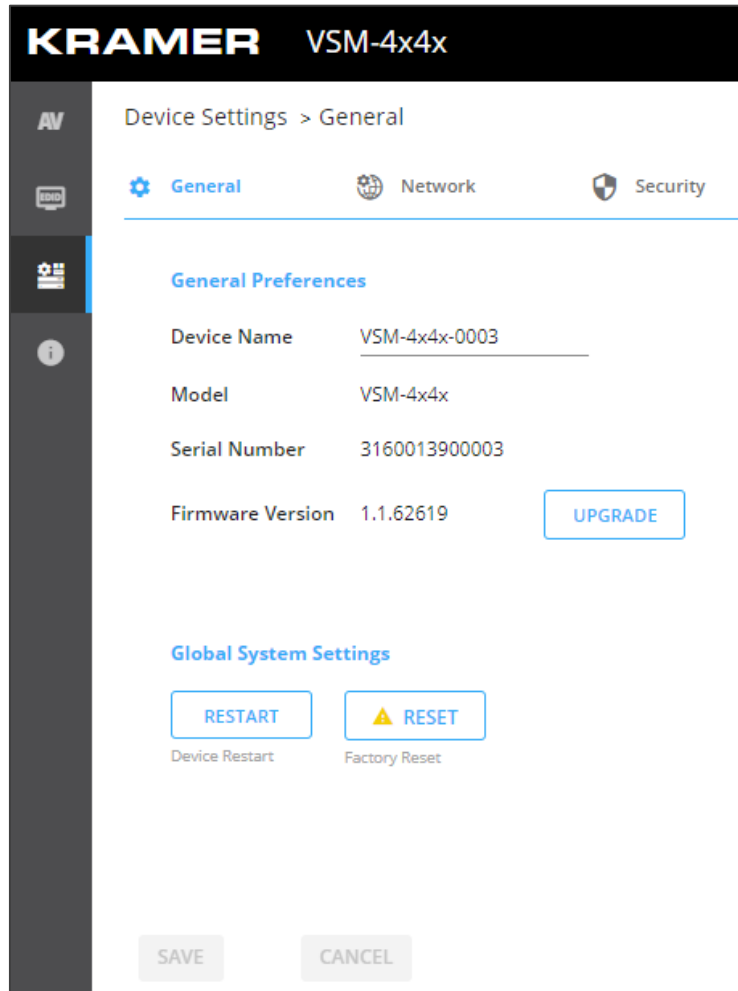

Figure 52: VSM-4x4x Device Settings – General

2. Next to Device Name, enter the new device name (Max. 14 characters).
3. Click **SAVE**.

Device name is changed.

## Upgrading Firmware

To update firmware:

1. In the navigation bar, click the **Device Settings** tab.  
The Device General Settings page appears ([Figure 52](#)).

2. Click **UPGRADE**.

A file browser appears.



3. Open the relevant firmware file.

The firmware uploads to the device.

## Restarting and Resetting the Device

Use the embedded web pages to restart the device and/or reset it to its default parameters.

**To restart/reset the device:**

1. In the navigation bar, click the **Device Settings** tab.

The Device General Settings page appears ([Figure 52](#)).

2. Click **RESTART/RESET**.

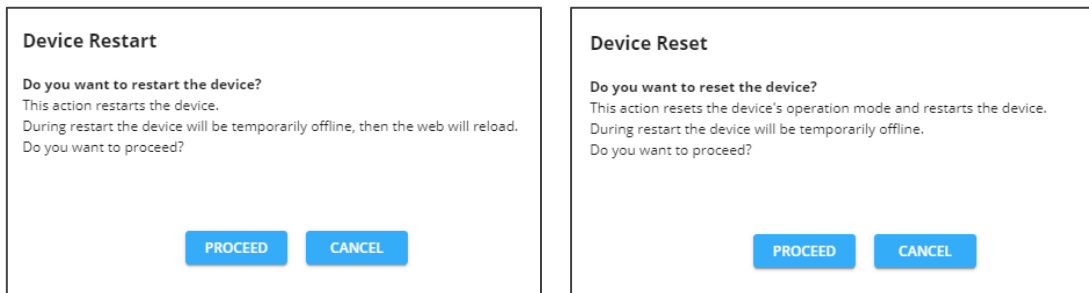

Figure 53: Restart/Reset the Device

3. Click **PROCEED**.

The device restarts/resets.

## Defining Interface Settings

Define the Ethernet port interface settings.

To define interface settings:

1. In the Navigation pane, Select **Device Settings**. The General tab in the Device Settings page appears (see [Figure 52](#)).
2. Select the **Network** tab. The Network tab appears.

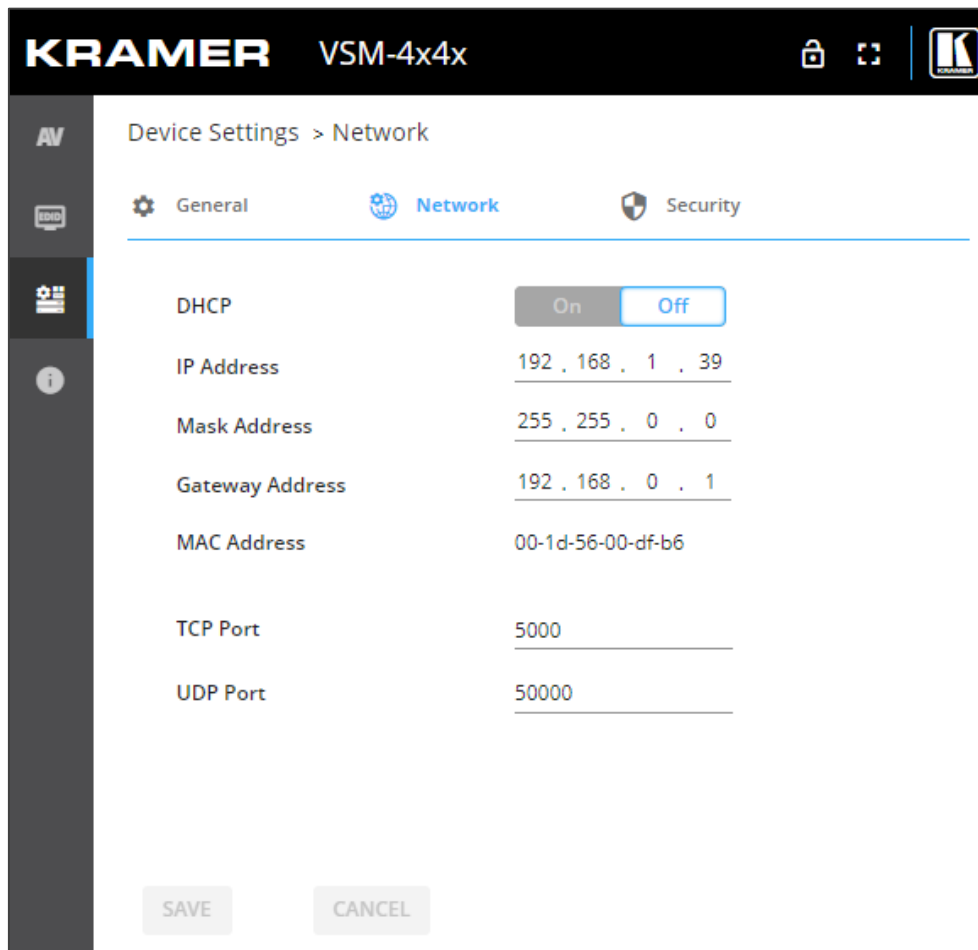

Figure 54: Device Settings – Network Tab

3. Set the Media port Stream service parameters:
  - **DHCP mode** – Set DHCP to **Off** (default) or **On**.
  - **IP Address** – When DHCP mode is set to Off, the device uses a static IP address. This requires entering mask and gateway addresses.
  - **Mask Address** – Enter subnet mask.
  - **Gateway address** – Enter the gateway address.
4. Define TCP (default, 5000) and UDP (default, 50000) ports.

Interface settings are defined.

## Defining VSM-4x4x User Access

The Security tab enables activating device security and defining logon authentication details. When device security is on, web page access requires authentication upon initial landing on operation page. The default password is **Admin**. By default, security is disabled.

### Enabling User Access

To enable security:

1. In the Navigation pane, click **Device Settings**. The General tab in the Device Settings page appears (see [Figure 52](#)).
2. Select Security tab.

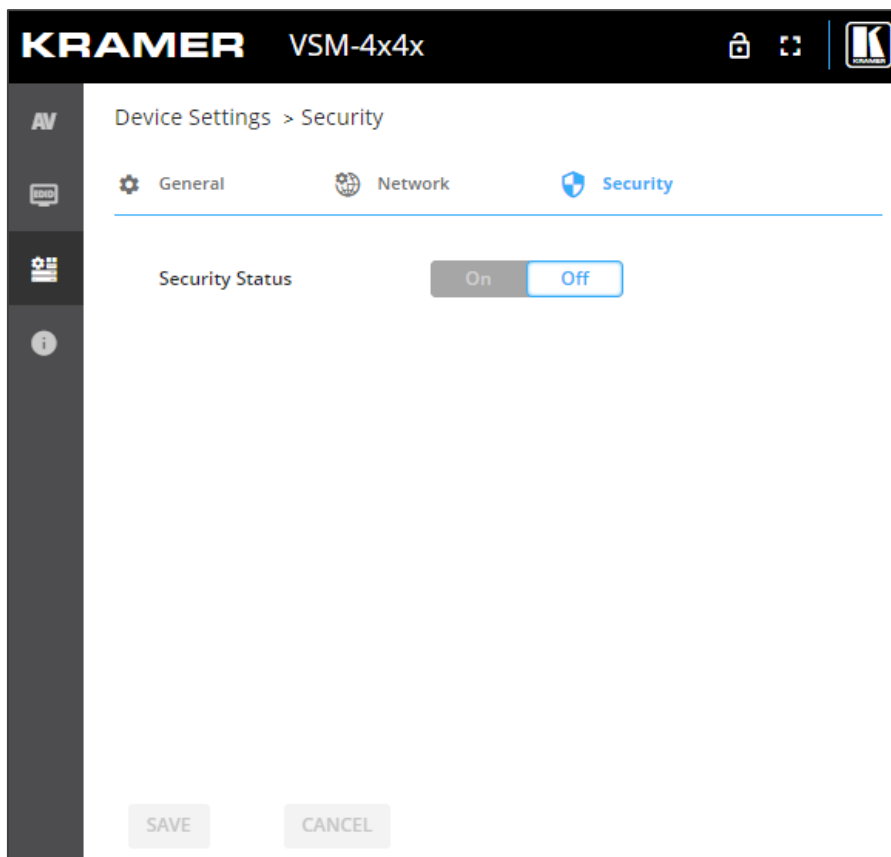

Figure 55: Device Settings – Users Tab

3. Click **On** next to Security Status to enable web page authentication (Off by default).

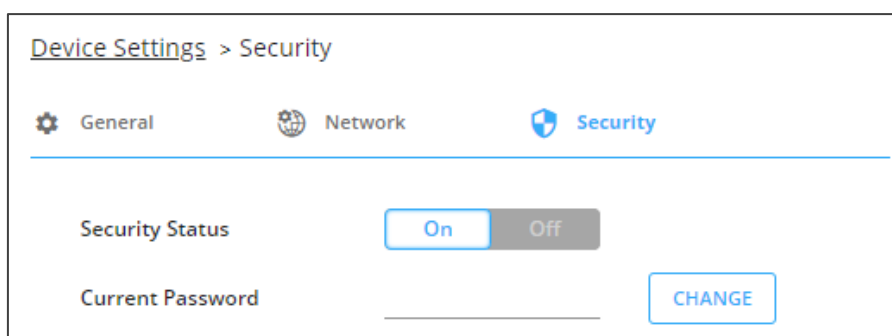

Figure 56: Security Tab – Security On

4. Click **CHANGE**.
5. Enter the new password and then confirm password.
6. Click **SAVE**.

Security is enabled and access requires authentication.

## Disabling User Access

### To enable security:

1. In the Navigation pane, click **Device Settings**. The General tab in the Device Settings page appears (see [Figure 52](#)).
2. Select Users tab (see [Figure 55](#)).

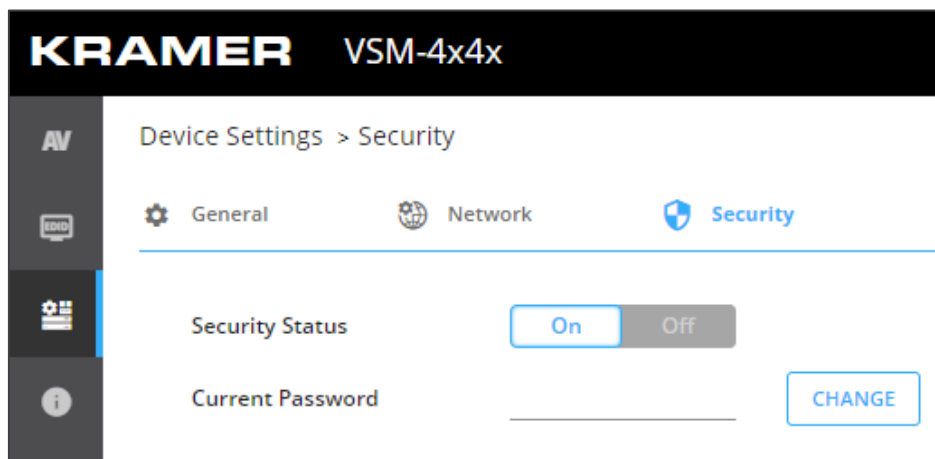

Figure 57: Device Settings – Users Tab

3. Click **Off** next to Security Status to enable web page authentication. The following message appears.

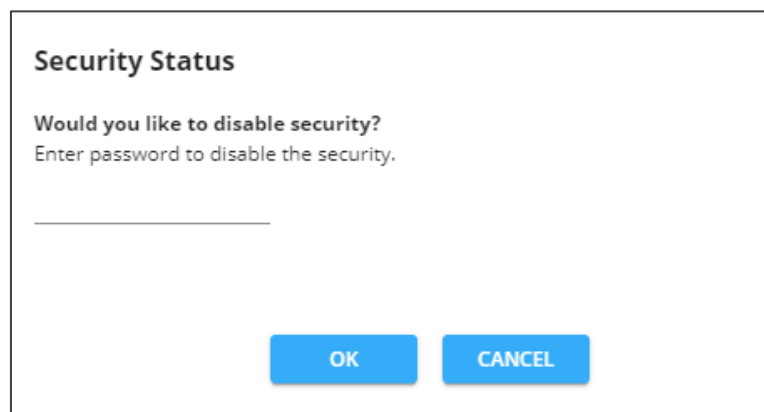

Figure 58: Security Tab – Security Status

4. Enter the current password.
5. Click **OK**.

Security is disabled.

## Changing the Password

To change the password:

1. In the Navigation pane, click **Device Settings**. The General tab in the Device Settings page appears (see [Figure 52](#)).
2. Select Users tab (see [Figure 55](#)).
3. Next to Current Password, enter the current password.
4. Click **CHANGE**.
5. Next to New Password, enter the new password.
6. Next to Confirm Password, enter the new password again.
7. Click **SAVE**.

Password has changed.

---

## Viewing the About Page

View the firmware version and Kramer Electronics Ltd details in the About page.

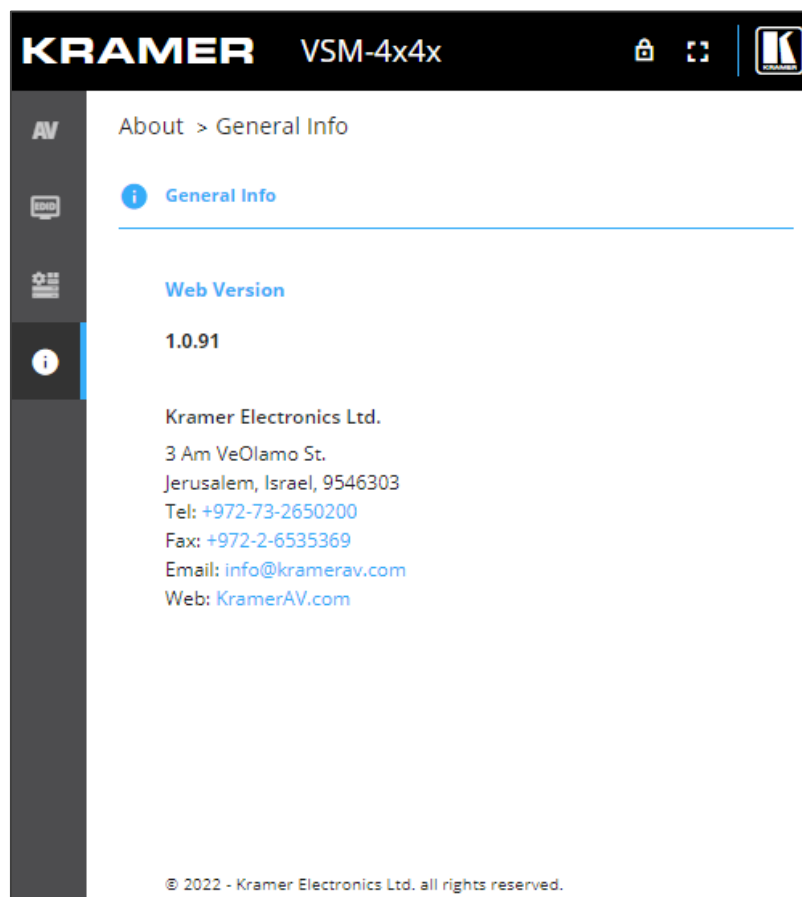

Figure 59: About Page

# Upgrading the Firmware

You can upgrade the firmware via the embedded web pages (see [Upgrading Firmware](#) on page [46](#)), or use the Kramer **K-UPLOAD** software to upgrade the firmware via the **VSM-4x4x** RS-232 port [18](#).

The latest version of **K-UPLOAD** and installation instructions can be downloaded from our website at: [www.kramerav.com/support/product\\_downloads.asp](http://www.kramerav.com/support/product_downloads.asp).

# Technical Specifications

Inputs	4HDMI	On female HDMI connectors
Outputs	4HDMI	On female HDMI connectors
	4 Balanced Stereo Line Level	On 5-pin terminal block connectors
Ports	1 RS-232	On a 3-pin terminal block
	1 Ethernet	On an RJ-45 female connector
Video	Max Bandwidth	18Gbps (6Gbps per graphic channel)
	Max Resolution	4K UHD @60Hz (4:2:0) 24bpp resolution
	Compliance	HDMI 2.0 and HDCP 1.4
Controls	Front Panel	Output and input selector buttons, system set up buttons (matrix, video wall and multi-view), store and recall buttons, display identify button, reset button and panel lock button
Analog Audio	Max Level	4.1Vrms when IN and OUT are at max 10db each
	Impedance	500Ω
	Bandwidth	20Hz - 20kHz
	Crosstalk	-114dBV
	THD + N	0.005% @1kHz at nominal level
	S/N Ratio	-89dB, 20Hz - 20kHz
	Coupling	DC
Power	Consumption	100-240V AC, 98VA max.
	Heat Dissipation	55W (188BTU/hr)
Environmental Conditions	Operating Temperature	0° to +40°C (32° to 104°F)
	Storage Temperature	-40° to +70°C (-40° to 158°F)
	Humidity	10% to 90%, RHL non-condensing
Regulatory Compliance	Safety	CE, FCC
	Environmental	RoHs, WEEE
Enclosure	Size	19" 1U
	Type	Aluminum
	Cooling	Fan Ventilation
General	Net Dimensions (W, D, H)	43.6cm x 18.3 cm x 4.4cm (17.2" x 7.2" x 1.7")
	Shipping Dimensions (W, D, H)	55cm x 27.6cm x 10.7cm (21.6" x 10.9" x 4.2")
	Net Weight	1.8kg (4lbs)
	Shipping Weight	2.9kg (6.4lbs) approx.
Accessories	Included	Power cord
Specifications are subject to change without notice at <a href="http://www.kramerav.com">www.kramerav.com</a>		

## Default Communication Parameters

RS-232	
Baud Rate:	115,200
Data Bits:	8
Stop Bits:	1
Parity:	None
Command Format:	ASCII
Example (set the viewing mode to Split Screen):	VIEW-MOD 7<CR>
Ethernet	
To reset the IP settings to the factory reset values go to: Menu->Setup -> Factory Reset-> press Enter to confirm	
IP Address:	192.168.1.39
Subnet mask:	255.255.255.0
Default gateway:	192.168.1.254
TCP Port #:	80
Maximum TCP Ports:	1
Default username:	Admin
Default password:	Admin
Full Factory Reset	
Rear panel	Press the RESET recessed button while powering the device.
P3K Commands	Use RESET and FACTORY commands.
Embedded web pages	See (see <a href="#">Restarting and Resetting the Device</a> on page 47).

## Default EDID

### Monitor

Model name..... VSM-4x4x  
 Manufacturer..... KMR  
 Plug and Play ID..... KMR1200  
 Serial number..... 295-883450100  
 Manufacture date..... 2018, ISO week 255  
 Filter driver..... None

EDID revision..... 1.3  
 Input signal type..... Digital  
 Color bit depth..... Undefined  
 Display type..... Monochrome/grayscale  
 Screen size..... 520 x 320 mm (24.0 in)  
 Power management..... Standby, Suspend, Active off/sleep  
 Extension blocs..... 1 (CEA/CTA-EXT)

DDC/CI..... Not supported

### Color characteristics

Default color space..... Non-sRGB  
 Display gamma..... 2.20  
 Red chromaticity..... Rx 0.674 - Ry 0.319  
 Green chromaticity..... Gx 0.188 - Gy 0.706  
 Blue chromaticity..... Bx 0.148 - By 0.064  
 White point (default).... Wx 0.313 - Wy 0.329  
 Additional descriptors... None

### Timing characteristics

Horizontal scan range.... 30-83kHz  
 Vertical scan range..... 56-76Hz  
 Video bandwidth..... 170MHz  
 CVT standard..... Not supported  
 GTF standard..... Not supported  
 Additional descriptors... None  
 Preferred timing..... Yes  
 Native/preferred timing.. 1920x1080p at 60Hz (16:9)  
 Modeline..... "1920x1080" 148.500 1920 2008 2052 2200 1080 1084 1089 1125 +hsync +vsync

### Standard timings supported

720 x 400p at 70Hz - IBM VGA



720 x 400p at 88Hz - IBM XGA2  
 640 x 480p at 60Hz - IBM VGA  
 640 x 480p at 67Hz - Apple Mac II  
 640 x 480p at 72Hz - VESA  
 640 x 480p at 75Hz - VESA  
 800 x 600p at 56Hz - VESA  
 800 x 600p at 60Hz - VESA  
 800 x 600p at 72Hz - VESA  
 800 x 600p at 75Hz - VESA  
 832 x 624p at 75Hz - Apple Mac II  
 1024 x 768i at 87Hz - IBM  
 1024 x 768p at 60Hz - VESA  
 1024 x 768p at 70Hz - VESA  
 1024 x 768p at 75Hz - VESA  
 1280 x 1024p at 75Hz - VESA  
 1152 x 870p at 75Hz - Apple Mac II  
 1280 x 1024p at 75Hz - VESA STD  
 1280 x 1024p at 85Hz - VESA STD  
 1600 x 1200p at 60Hz - VESA STD  
 1024 x 768p at 85Hz - VESA STD  
 800 x 600p at 85Hz - VESA STD  
 640 x 480p at 85Hz - VESA STD  
 1152 x 864p at 70Hz - VESA STD  
 1280 x 960p at 60Hz - VESA STD

#### EIA/CEA/CTA-861 Information

Revision number..... 3  
 IT underscan..... Supported  
 Basic audio..... Supported  
 YCbCr 4:4:4..... Not supported  
 YCbCr 4:2:2..... Not supported  
 Native formats..... 1  
 Detailed timing #1..... 1920x1080p at 60Hz (16:10)  
 Modeline..... "1920x1080" 148.500 1920 2008 2052 2200 1080 1084 1089 1125 +hsync +vsync  
 Detailed timing #2..... 1920x1080i at 60Hz (16:10)  
 Modeline..... "1920x1080" 74.250 1920 2008 2052 2200 1080 1084 1094 1124 interlace +hsync +vsync  
 Detailed timing #3..... 1280x720p at 60Hz (16:10)  
 Modeline..... "1280x720" 74.250 1280 1390 1430 1650 720 725 730 750 +hsync +vsync  
 Detailed timing #4..... 720x480p at 60Hz (16:10)  
 Modeline..... "720x480" 27.000 720 736 798 858 480 489 495 525 -hsync -vsync

#### CE audio data (formats supported)

LPCM 2-channel, 16/20/24 bit depths at 32/44/48 kHz

#### CE video identifiers (VICs) - timing/formats supported

1920 x 1080p at 60Hz - HDTV (16:9, 1:1) [Native]  
 1920 x 1080i at 60Hz - HDTV (16:9, 1:1)  
 1280 x 720p at 60Hz - HDTV (16:9, 1:1)  
 720 x 480p at 60Hz - EDTV (16:9, 32:27)  
 720 x 480p at 60Hz - EDTV (4:3, 8:9)  
 720 x 480i at 60Hz - Doublescan (16:9, 32:27)  
 720 x 576i at 50Hz - Doublescan (16:9, 64:45)  
 640 x 480p at 60Hz - Default (4:3, 1:1)  
 NB: NTSC refresh rate = (Hz\*1000)/1001

#### CE vendor specific data (VSDB)

IEEE registration number. 0x000C03  
 CEC physical address..... 1.0.0.0  
 Maximum TMDS clock..... 165MHz

#### CE speaker allocation data

Channel configuration.... 2.0  
 Front left/right..... Yes  
 Front LFE..... No  
 Front center..... No  
 Rear left/right..... No  
 Rear center..... No  
 Front left/right center.. No  
 Rear left/right center... No  
 Rear LFE..... No

#### Report information

Date generated..... 20/03/2022  
 Software revision..... 2.91.0.1043  
 Data source..... Real-time 0x0061  
 Operating system..... 10.0.18363.2

#### Raw data

00,FF,FF,FF,FF,FF,FF,00,2D,B2,00,12,01,01,01,01,FF,1C,01,03,80,34,20,78,E2,B3,25,AC,51,30,B4,26,  
 10,50,54,FF,FF,80,81,8F,81,99,A9,40,61,59,45,59,31,59,71,4A,81,40,02,3A,80,18,71,38,2D,40,58,2C,  
 45,00,A0,5A,00,00,00,1E,00,00,00,FF,00,32,39,35,2D,38,38,33,34,35,30,31,30,30,00,00,00,FC,00,56,  
 53,4D,2D,34,78,34,78,0A,20,20,20,00,00,00,FD,00,38,4C,1E,53,11,00,0A,20,20,20,20,20,01,0F,



# Protocol 3000

Kramer devices can be operated using Kramer Protocol 3000 commands sent via serial or Ethernet ports.

## Understanding Protocol 3000

Protocol 3000 commands are a sequence of ASCII letters, structured according to the following.

- **Command format:**

Prefix	Command Name	Constant (Space)	Parameter(s)	Suffix
#	Command	_	Parameter	<CR>

- **Feedback format:**

Prefix	Device ID	Constant	Command Name	Parameter(s)	Suffix
~	nn	@	Command	Parameter	<CR><LF>

- **Command parameters** – Multiple parameters must be separated by a comma (,). In addition, multiple parameters can be grouped as a single parameter using brackets ([ and ]).
- **Command chain separator character** – Multiple commands can be chained in the same string. Each command is delimited by a pipe character (|).
- **Parameters attributes** – Parameters may contain multiple attributes. Attributes are indicated with pointy brackets (<...>) and must be separated by a period (.).

The command framing varies according to how you interface with **VSM-4x4x**. The following figure displays how the # command is framed using terminal communication software (such as Hercules):

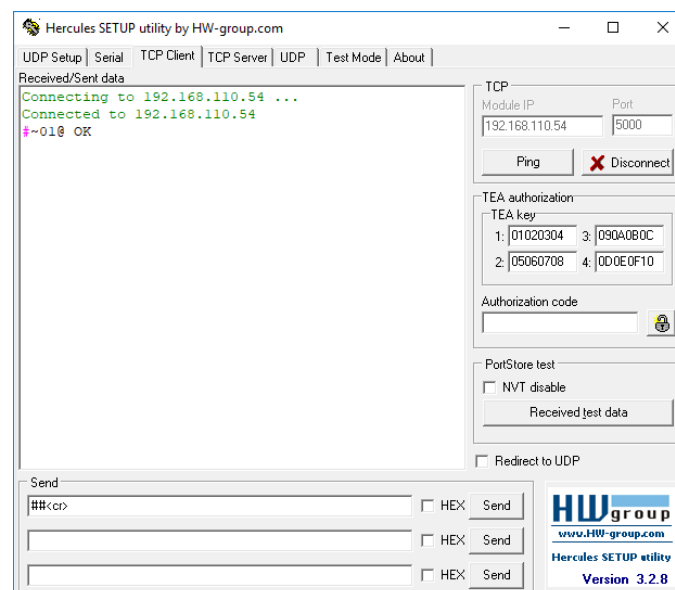

# Protocol 3000 Commands

Function	Description	Syntax	Parameters/Attributes	Example
#	<p>Protocol handshaking.</p> <p>① Validates the Protocol 3000 connection and gets the machine number.</p> <p>Step-in master products use this command to identify the availability of a device.</p>	<p><b>COMMAND</b></p> <pre>#&lt;CR&gt;</pre> <p><b>FEEDBACK</b></p> <pre>~nn@_ok&lt;CR&gt;&lt;LF&gt;</pre>		#<CR>
AUD-LVL	Set volume level.	<p><b>COMMAND</b></p> <pre>#AUD-LVL_{io_mode,io_index,vol_db}&lt;CR&gt;</pre> <p><b>FEEDBACK</b></p> <pre>~nn@AUD-LVL_{io_mode,io_index,vol_level}&lt;CR&gt;&lt;LF&gt;</pre>	<p><b>io_mode</b> – Input/Output 0 – Input 1 – Output</p> <p><b>io_index</b> – Number that indicates the specific input or output port: 1-4</p> <p><b>vol_db</b> – Volume level -80db to 10dB; ++ (increase current value by 1dB); -- (decrease current value by 1dB)</p>	Set OUT 2 AUDIO level to -50dB: #AUD-LVL_{1,2,-50}<CR>
AUD-LVL?	Get volume level.	<p><b>COMMAND</b></p> <pre>#AUD-LVL?_{io_mode,io_index}&lt;CR&gt;</pre> <p><b>FEEDBACK</b></p> <pre>~nn@AUD-LVL_{io_mode,io_index,vol_db}&lt;CR&gt;&lt;LF&gt;</pre>	<p><b>io_mode</b> – Input/Output 0 – Input 1 – Output</p> <p><b>io_index</b> – Number that indicates the specific input or output port: 1-4</p> <p><b>vol_db</b> – Volume level -80db to 10dB; ++ (increase current value by 1dB); -- (decrease current value by 1dB)</p>	Get AUDIO OUT 1 level #AUD-LVL?_{1,1}<CR>
AUD-LVL-RANGE?	<p>Get audio level min and max range.</p> <p>① In most devices min and max audio level is a function of HW implementation and the SET command is usually not implemented.</p>	<p><b>COMMAND</b></p> <pre>#AUD-LVL-RANGE?_{io_mode,io_index}&lt;CR&gt;</pre> <p><b>FEEDBACK</b></p> <pre>~nn@AUD-LVL-RANGE_{io_mode,io_index,min_vol,max_vol}&lt;CR&gt;&lt;LF&gt;</pre>	<p><b>io_mode</b> – Input/Output 0 – Input 1 – Output</p> <p><b>io_index</b> – Number that indicates the specific input or output port: 1-4</p> <p><b>min_vol</b> – Minimal available audio level <b>max_vol</b> – Maximum available audio level</p>	Get audio level min and max range for output 2: #AUD-LVL-RANGE?_{1,2}<CR>
AUD-SIG-TYPE	N/A			
AUD-SIG-TYPE?	N/A			
BEACON-INFO?	<p>Get beacon information, including IP address, UDP control port, TCP control port, MAC address, model, name.</p> <p>① There is no Set command. Get command initiates a notification.</p>	<p><b>COMMAND</b></p> <pre>#BEACON-INFO?_{port_id}&lt;CR&gt;</pre> <p><b>FEEDBACK</b></p> <pre>~nn@BEACON-INFO_{port_id,ip_string,udp_port,tcp_port,mac_address,model,name}&lt;CR&gt;&lt;LF&gt;</pre>	<p><b>port_id</b> – 0</p> <p><b>ip_string</b> – Dot-separated representation of the IP address</p> <p><b>udp_port</b> – UDP control port</p> <p><b>tcp_port</b> – TCP control port</p> <p><b>mac_address</b> – Dash-separated mac address</p> <p><b>model</b> – Device model</p> <p><b>name</b> – Device name</p>	Get beacon information: #BEACON-INFO?_{0}<CR>
BRIGHTNESS	<p>Set image brightness per output.</p> <p>① Value limits can vary for different devices.</p> <p>Value is a property of input connected to current output. Changing input source might cause changes in this value (refer device definitions).</p> <p>In devices that enable showing multiple outputs on one display – each in a separate window – this command relates only to the window associated with the output indicated in the out-index parameter.</p>	<p><b>COMMAND</b></p> <pre>#BRIGHTNESS_{out_index,value}&lt;CR&gt;</pre> <p><b>FEEDBACK</b></p> <pre>~nn@BRIGHTNESS_{out_index,value}&lt;CR&gt;&lt;LF&gt;</pre>	<p><b>out_index</b> – Number that indicates the specific output: 1-4</p> <p><b>value</b> – Brightness value</p>	Set brightness for output 1 to 50: #BRIGHTNESS_{1,50}<CR>

Function	Description	Syntax	Parameters/Attributes	Example
<b>BRIGHTNESS?</b>	<p>Get image brightness per output.</p> <p>ⓘ Value limits can vary for different devices.</p> <p>Value is a property of input connected to current output. Changing input source might cause changes in this value (refer device definitions).</p> <p>In devices that enable showing multiple outputs on one display – each in a separate window – this command relates only to the window associated with the output indicated in the out-index parameter.</p>	<p><b>COMMAND</b></p> <pre>#BRIGHTNESS?_out_index&lt;CR&gt;</pre> <p><b>FEEDBACK</b></p> <pre>~nn@BRIGHTNESS_out_index,value&lt;CR&gt;&lt;LF&gt;</pre>	<p><b>out_index</b> – Number that indicates the specific output: 1-4</p> <p><b>value</b> – Brightness value</p>	<p>Get brightness for output 1:</p> <pre>#BRIGHTNESS?_1&lt;CR&gt;</pre>
<b>BUILD-DATE?</b>	<p>Get device build date.</p>	<p><b>COMMAND</b></p> <pre>#BUILD-DATE?_&lt;CR&gt;</pre> <p><b>FEEDBACK</b></p> <pre>~nn@BUILD-DATE_date,time&lt;CR&gt;&lt;LF&gt;</pre>	<p><b>date</b> – Format: YYYY/MM/DD where        YYYY = Year        MM = Month        DD = Day</p> <p><b>time</b> – Format: hh:mm:ss where        hh = hours        mm = minutes        ss = seconds</p>	<p>Get the device build date:</p> <pre>#BUILD-DATE?&lt;CR&gt;</pre>
<b>CONF-EXPORT</b>	<p>Export configuration file.</p>	<p><b>COMMAND</b></p> <pre>#CONF-EXPORT_&lt;CR&gt;</pre> <p><b>FEEDBACK</b></p> <pre>~nn@CONF-EXPORT_system/export/VSM4x4H2_Configuration.bin&lt;CR&gt;&lt;LF&gt;</pre>		<p>Export configuration file:</p> <pre>#COM-EXPORT_&lt;CR&gt;</pre>
<b>CONTRAST</b>	<p>Set image contrast per output.</p> <p>ⓘ Value limits can vary for different devices.</p> <p>Value is a property of input connected to current output. Changing the input source might cause changes in this value (refer to device definitions).</p> <p>In devices that enable showing multiple outputs on one display – each in a separate window – this command relates only to the window associated with the output indicated in the out-index parameter.</p>	<p><b>COMMAND</b></p> <pre>#CONTRAST_out_index,value&lt;CR&gt;</pre> <p><b>FEEDBACK</b></p> <pre>~nn@CONTRAST_out_index,value&lt;CR&gt;&lt;LF&gt;</pre>	<p><b>out_index</b> – Number that indicates the specific output: 1-4</p> <p><b>value</b> – Contrast value</p>	<p>Set contrast for output 1 to 40:</p> <pre>#CONTRAST_1,40&lt;CR&gt;</pre>
<b>CONTRAST?</b>	<p>Get image contrast per output.</p> <p>ⓘ Value limits can vary for different devices.</p> <p>Value is a property of input connected to current window. Changing the window input source might cause changes in this value (refer to device definitions).</p> <p>In devices that enable showing multiple outputs on one display – each in a separate window – this command relates only to the window associated with the output indicated in the out-index parameter.</p>	<p><b>COMMAND</b></p> <pre>#CONTRAST?_out_index&lt;CR&gt;</pre> <p><b>FEEDBACK</b></p> <pre>~nn@CONTRAST_out_index,value&lt;CR&gt;&lt;LF&gt;</pre>	<p><b>out_index</b> – Number that indicates the specific output: 1-N (N= the total number of outputs)</p> <p><b>value</b> – Contrast value</p>	<p>Get contrast for output 1:</p> <pre>#CONTRAST?_1&lt;CR&gt;</pre>

Function	Description	Syntax	Parameters/Attributes	Example
CPEDID	<p>Copy EDID data from the output to the input EEPROM.</p> <p>ⓘ Destination bitmap size depends on device properties (for 64 inputs it is a 64-bit word).</p> <p>Example: bitmap 0x0013 means inputs 1,2 and 5 are loaded with the new EDID.</p> <p>In certain products Safe_mode is an optional parameter. See the HELP command for its availability.</p>	<p><b>COMMAND</b></p> <pre>#CPEDID_&lt;edid_io&gt;,&lt;src_id&gt;,&lt;edid_io&gt;,&lt;dest_bitmap&gt;&lt;CR&gt;</pre> <p>or</p> <pre>#CPEDID_&lt;edid_io&gt;,&lt;src_id&gt;,&lt;edid_io&gt;,&lt;dest_bitmap&gt;,&lt;safe_mode&gt;&lt;CR&gt;</pre> <p><b>FEEDBACK</b></p> <pre>~nn@CPEDID_&lt;edid_io&gt;,&lt;src_id&gt;,&lt;edid_io&gt;,&lt;dest_bitmap&gt;&lt;CR&gt;&lt;LF&gt;</pre> <pre>~nn@CPEDID_&lt;edid_io&gt;,&lt;src_id&gt;,&lt;edid_io&gt;,&lt;dest_bitmap&gt;,&lt;safe_mode&gt;&lt;CR&gt;&lt;LF&gt;</pre>	<p><b>edid_io</b> – EDID source type (usually output)</p> <ul style="list-style-type: none"> <li>0 – Input</li> <li>1 – Output</li> <li>2 – Default EDID</li> <li>3 – Custom EDID</li> </ul> <p><b>src_id</b> – Number of chosen source stage</p> <ul style="list-style-type: none"> <li>0 – Default EDID source</li> <li>1 – Output 1</li> <li>2 – Output 2</li> <li>3 – Output 3</li> <li>4 – Output 4</li> </ul> <p><b>edid_io</b> – EDID destination type (usually input)</p> <ul style="list-style-type: none"> <li>0 – Input</li> <li>1 – Output</li> <li>2 – Default EDID</li> <li>3 – Custom EDID</li> </ul> <p><b>dest_bitmap</b> – Bitmap representing destination IDs. Format: XXXX...X, where X is hex digit. The binary form of every hex digit represents corresponding destinations.</p> <ul style="list-style-type: none"> <li>0 – indicates that EDID data is not copied to this destination.</li> <li>1 – indicates that EDID data is copied to this destination.</li> </ul> <p><b>safe_mode</b> – Safe mode</p> <ul style="list-style-type: none"> <li>0 – device accepts the EDID as is without trying to adjust</li> <li>1 – device tries to adjust the EDID (default value if no parameter is sent)</li> </ul>	<p>Copy the EDID data from the Output 1 (EDID source) to the Input:</p> <pre>#CPEDID_1,1,0,0x1&lt;CR&gt;</pre> <p>Copy the EDID data from the default EDID source to the Input:</p> <pre>#CPEDID_2,0,0,0x1&lt;CR&gt;</pre>
DISPLAY?	Get output HPD status.	<p><b>COMMAND</b></p> <pre>#DISPLAY?_&lt;out_index&gt;&lt;CR&gt;</pre> <p><b>FEEDBACK</b></p> <pre>~nn@DISPLAY_&lt;out_index&gt;,&lt;status&gt;&lt;CR&gt;&lt;LF&gt;</pre>	<p><b>out_index</b> – Number that indicates the specific output:</p> <ul style="list-style-type: none"> <li>1-4</li> </ul> <p><b>status</b> – HPD status according to signal validation</p> <ul style="list-style-type: none"> <li>0 – Signal or sink is not valid</li> <li>1 – Signal or sink is valid</li> <li>2 – Sink and EDID is valid</li> </ul>	Get the output HPD status of Output 1:
EDID-AUDIO	Set audio capabilities for EDID.	<p><b>COMMAND</b></p> <pre>#EDID-AUDIO_&lt;io_index&gt;,&lt;audio_format&gt;&lt;CR&gt;</pre> <p><b>FEEDBACK</b></p> <pre>~nn@EDID-AUDIO_&lt;io_index&gt;,&lt;audio_format&gt;&lt;CR&gt;&lt;LF&gt;</pre>	<p><b>io_index</b> – Number that indicates the specific input port:</p> <ul style="list-style-type: none"> <li>1-4</li> </ul> <p><b>audio_format</b> – Audio block added to EDID:</p> <ul style="list-style-type: none"> <li>0 – Auto</li> <li>1 – LPCM 2CH</li> <li>2 – LPCM 6CH</li> <li>3 – LPCM 8CH</li> <li>4 – Bitstream</li> <li>5 – HD</li> </ul>	Set HDMI IN 1 audio capabilities for EDID (LPCM 6CH):
EDID-AUDIO?	Get audio capabilities for EDID.	<p><b>COMMAND</b></p> <pre>#EDID-AUDIO?_&lt;io_index&gt;&lt;CR&gt;</pre> <p><b>FEEDBACK</b></p> <pre>~nn@EDID-AUDIO_&lt;io_index&gt;,&lt;audio_format&gt;&lt;CR&gt;&lt;LF&gt;</pre>	<p><b>io_index</b> – Number that indicates the specific input port:</p> <ul style="list-style-type: none"> <li>1-4</li> </ul> <p><b>audio_format</b> – Audio block added to EDID:</p> <ul style="list-style-type: none"> <li>0 – Auto</li> <li>1 – LPCM 2CH</li> <li>2 – LPCM 6CH</li> <li>3 – LPCM 8CH</li> <li>4 – Bitstream</li> <li>5 – HD</li> </ul>	Get HDMI IN 1 audio capabilities for EDID:
EDID-CS	<p>Set EDID color space.</p> <p>ⓘ Set command might change the current EDID.</p>	<p><b>COMMAND</b></p> <pre>#EDID-CS_&lt;direction_type&gt;.&lt;port_format&gt;.&lt;port_index&gt;.&lt;signal_type&gt;.&lt;index&gt;,&lt;cs_mode&gt;&lt;CR&gt;</pre> <p><b>FEEDBACK</b></p> <pre>~nn@EDID-CS_&lt;direction_type&gt;.&lt;port_format&gt;.&lt;port_index&gt;.&lt;signal_type&gt;.&lt;index&gt;,&lt;cs_mode&gt;&lt;CR&gt;&lt;LF&gt;</pre>	<p>The following attributes comprise the signal ID:</p> <ul style="list-style-type: none"> <li>▪ <b>&lt;direction_type&gt;</b> – Direction of the port: <ul style="list-style-type: none"> <li>o IN – Input</li> <li>o OUT – Output</li> </ul> </li> <li>▪ <b>&lt;port_format&gt;</b> – Type of signal on the port: <ul style="list-style-type: none"> <li>o HDMI</li> <li>o ANALOG_AUDIO</li> </ul> </li> <li>▪ <b>&lt;port_index&gt;</b> – 1-4</li> <li>▪ <b>&lt;signal_type&gt;</b> – Signal ID attribute: <ul style="list-style-type: none"> <li>o AUDIO</li> </ul> </li> <li>▪ <b>&lt;index&gt;</b> 1</li> </ul> <p><b>cs_mode</b> – Color space</p> <ul style="list-style-type: none"> <li>0 – RGB</li> <li>1 – RGB + YUV444</li> <li>2 – RGB + YUV422</li> <li>3 – RGB + YUV444 + YUV422</li> <li>4 – auto</li> </ul>	Set HDMI IN 3 EDID color space to RGB (enabled):

Function	Description	Syntax	Parameters/Attributes	Example
EDID-CS?	Get EDID color space.  ① Get command might change the current EDID.	<b>COMMAND</b> #EDID-CS?,<direction_type>.<port_format>.<port_index>.<signal_type>.<index><CR> <b>FEEDBACK</b> ~nn@EDID-CS,<direction_type>.<port_format>.<port_index>.<signal_type>.<index>,<cs_mode><CR><LF>	The following attributes comprise the signal ID: ▪ <direction_type> – Direction of the port: ○ IN – Input ○ OUT – Output ▪ <port_format> – Type of signal on the port: ○ HDMI ○ ANALOG_AUDIO ▪ <port_index> – 1-4 ▪ <signal_type> – Signal ID attribute: ○ AUDIO ▪ <index> 1 cs_mode – Color space 0 – RGB 1 – RGB + YUV444 2 – RGB + YUV422 3 – RGB + YUV444 + YUV422 4 – auto	Get EDID color space: #EDID-CS?,<in.hdmi.3.audio.1,0><CR>
EDID-DC	Force removal of deep color on EDID or leaving it as in the original EDID.	<b>COMMAND</b> #EDID-DC,<in_index>,<deep_color_state><CR> <b>FEEDBACK</b> Get: ~nn@EDID-DC,<in_index>,<deep_color_state><CR><LF>	in_index – Number that indicates the specific input: 1-4 deep_color_state – 0 – Don't change 1 – Remove deep color	#EDID-DC,<1,1><CR> ~01 @ EDID-DC 1,1
EDID-DC?	Get the input's deep color removal status.	<b>COMMAND</b> #EDID-DC?,<in_index><CR> <b>FEEDBACK</b> Get: ~nn@EDID-DC,<in_index>,<deep_color_state><CR><LF>	in_index – Number that indicates the specific input: 1-4 deep_color_state – 0 – Don't change 1 – Remove deep color	#EDID-DC,<1,1><CR> ~01 @ EDID-DC 1,1
EQ-LVL	Set equalization level.	<b>COMMAND</b> #EQ-LVL,<io_mode>,<io_index>,<eq_type>,<eq_level><CR> <b>FEEDBACK</b> ~nn@EQ-LVL,<io_mode>,<io_index>,<eq_type>,<eq_level><CR><LF>	io_mode – Input/Output 0 – Input 1 – Output io_index – Number that indicates the specific input or output port: 1-N (N= the total number of input or output ports) eq_type – Equalizer Types 0 – Bass 1 – Middle 2 – Treble eq_level – Equalizer level (±15DB for the PA-120Z project)	Set Bass EQ level of the speaker output to 12: #EQ-LVL,<1,1,0,12><CR>
ETH-PORT	Set Ethernet port protocol.  ① If the port number you enter is already in use, an error is returned. The port number must be within the following range: 0-(2 <sup>16</sup> -1).	<b>COMMAND</b> #ETH-PORT,<port_type>,<port_id><CR> <b>FEEDBACK</b> ~nn@ETH-PORT,<port_type>,<port_id><CR><LF>	port_type – TCP/UDP 0 – TCP 1 – UDP port_id – TCP/UDP port number (0 – 65535)	Set the Ethernet port protocol for TCP to port 12457: #ETH-PORT,<0,12457><CR>
ETH-PORT?	Get Ethernet port protocol.	<b>COMMAND</b> #ETH-PORT?,<port_type><CR> <b>FEEDBACK</b> ~nn@ETH-PORT,<port_type>,<port_id><CR><LF>	port_type – TCP/UDP 0 – TCP 1 – UDP port_id – TCP / UDP port number (0 – 65535)	Get the Ethernet port protocol for UDP: #ETH-PORT?,<1><CR>
FACTORY	Reset device to factory default configuration.  ① This command deletes all user data from the device. The deletion can take some time.  Your device may require powering off and powering on for the changes to take effect.	<b>COMMAND</b> #FACTORY<CR> <b>FEEDBACK</b> ~nn@FACTORY,<ok><CR><LF>		Reset the device to factory default configuration: #FACTORY<CR>
FEATURE-LIST?	Get feature state according to the feature ID.	<b>COMMAND</b> #FEATURE-LIST?,<feature_id><CR> <b>FEEDBACK</b> ~nn@FEATURE-LIST,<feature_id>,<ir_state><CR><LF>	feature_id – Feature ID) 1 – Maestro 2 – Room controller 3 – Maestro panel ir_state – IR interface 0 – disable 1 – enable	Get the room controller feature state (for the room controller 1): #FEATURE-LIST?,<1><CR>
FORMAT	Format file system.  ① Response could take several seconds until formatting completes.	<b>COMMAND</b> #FORMAT<CR> <b>FEEDBACK</b> ~nn@FORMAT,<ok><CR><LF>		#FORMAT<CR>

Function	Description	Syntax	Parameters/Attributes	Example
GEDID	<p>Get EDID support on certain input/output.</p> <p>① For old devices that do not support this command, <code>-nn@ERR 002&lt;CR&gt;&lt;LF&gt;</code> is received.</p>	<p><b>COMMAND</b></p> <pre>#GEDID_&lt;io_mode&gt;,&lt;in_index&gt;&lt;CR&gt;</pre> <p><b>FEEDBACK</b></p> <pre>~nn@GEDID_&lt;io_mode&gt;,&lt;in_index&gt;,&lt;size&gt;,&lt;edid_string&gt;&lt;CR&gt;&lt;LF&gt;</pre>	<p><b>io_mode</b> – Input/Output</p> <ul style="list-style-type: none"> <li>0 – Input</li> <li>1 – Output</li> <li>2 – Default EDID</li> </ul> <p><b>in_index</b> – Number that indicates the specific input:</p> <ul style="list-style-type: none"> <li>1-4</li> </ul> <p><b>size</b> – Size of data to be sent from device, 0 means no EDID support</p> <p><b>edid_string</b> – EDID content</p>	<p>Get EDID support information for input 1:</p> <pre>#GEDID_0,1&lt;CR&gt;</pre>
HDCP-MOD	<p>Set HDCP mode for input.</p> <p>① Set HDCP working mode on the device input:</p> <p>HDCP supported - HDCP_ON [default].</p> <p>HDCP not supported - HDCP OFF.</p> <p>HDCP support changes following detected sink - MIRROR OUTPUT.</p> <p>When you define 3 as the mode, the HDCP status is defined according to the connected output in the following priority: OUT 1, OUT 2. If the connected display on OUT 2 supports HDCP, but OUT 1 does not, then HDCP is defined as not supported. If OUT 1 is not connected, then HDCP is defined by OUT 2.</p>	<p><b>COMMAND</b></p> <pre>#HDCP-MOD_&lt;in_index&gt;,&lt;mode&gt;&lt;CR&gt;</pre> <p><b>FEEDBACK</b></p> <pre>~nn@HDCP-MOD_&lt;in_index&gt;,&lt;mode&gt;&lt;CR&gt;&lt;LF&gt;</pre>	<p><b>in_index</b> – Number that indicates the specific input:</p> <ul style="list-style-type: none"> <li>1-4</li> </ul> <p><b>mode</b> – HDCP mode:</p> <ul style="list-style-type: none"> <li>0 – HDCP Off</li> <li>1 – HDCP On</li> <li>2 – Follow Input</li> <li>3 – Follow Output</li> </ul>	<p>Set the input HDCP-MODE of IN 1 to Off:</p> <pre>#HDCP-MOD_1,0&lt;CR&gt;</pre>
HDCP-MOD?	<p>Get HDCP mode for input.</p> <p>① Set HDCP working mode on the device input:</p> <p>HDCP supported - HDCP_ON [default].</p> <p>HDCP not supported - HDCP OFF.</p> <p>HDCP support changes following detected sink - MIRROR OUTPUT.</p>	<p><b>COMMAND</b></p> <pre>#HDCP-MOD?_&lt;in_index&gt;&lt;CR&gt;</pre> <p><b>FEEDBACK</b></p> <pre>~nn@HDCP-MOD_&lt;in_index&gt;,&lt;mode&gt;&lt;CR&gt;&lt;LF&gt;</pre>	<p><b>in_index</b> – Number that indicates the specific input:</p> <ul style="list-style-type: none"> <li>1-4</li> </ul> <p><b>mode</b> – HDCP mode:</p> <ul style="list-style-type: none"> <li>0 – HDCP Off</li> <li>1 – HDCP On</li> <li>2 – Follow Input</li> <li>3 – Follow Output</li> </ul>	<p>Get the input HDCP-MODE of IN 1 HDMI:</p> <pre>#HDCP-MOD?_1&lt;CR&gt;</pre>
HDCP-OUT	<p>Set HDCP mode for output.</p>	<p><b>COMMAND</b></p> <pre>#HDCP-OUT_&lt;out_index&gt;,&lt;mode&gt;&lt;CR&gt;</pre> <p><b>FEEDBACK</b></p> <pre>~nn@HDCP-MOD_&lt;in_index&gt;,&lt;mode&gt;&lt;CR&gt;&lt;LF&gt;</pre>	<p><b>out_index</b> – Number that indicates the specific output:</p> <ul style="list-style-type: none"> <li>1-4</li> </ul> <p><b>mode</b> – HDCP mode:</p> <ul style="list-style-type: none"> <li>0 – HDCP Off</li> <li>1 – HDCP 1.4</li> <li>2 – HDCP 2.2</li> </ul>	<p>Set the output HDCP-OUT mode of OUT 1 to Off:</p> <pre>#HDCP-OUT_1,0&lt;CR&gt;</pre>
HDCP-OUT?	<p>Get HDCP mode.</p>	<p><b>COMMAND</b></p> <pre>#HDCP-OUT?_&lt;out_index&gt;&lt;CR&gt;</pre> <p><b>FEEDBACK</b></p> <pre>~nn@HDCP-OUT_&lt;out_index&gt;,&lt;mode&gt;&lt;CR&gt;&lt;LF&gt;</pre>	<p><b>out_index</b> – Number that indicates the specific output:</p> <ul style="list-style-type: none"> <li>1-4</li> </ul> <p><b>mode</b> – HDCP mode:</p> <ul style="list-style-type: none"> <li>0 – HDCP Off</li> <li>1 – HDCP 1.4</li> <li>2 – Follow 2.2</li> </ul>	<p>Get the input HDCP-OUT mode of IN 1 HDMI:</p> <pre>#HDCP-OUT?_1&lt;CR&gt;</pre>
HDCP-STAT?	<p>Get HDCP signal status.</p> <p>① <code>io_mode=1</code> – get the HDCP signal status of the sink device connected to the specified output.</p> <p><code>io_mode=0</code> – get the HDCP signal status of the source device connected to the specified input.</p>	<p><b>COMMAND</b></p> <pre>#HDCP-STAT?_&lt;io_mode&gt;,&lt;in_index&gt;&lt;CR&gt;</pre> <p><b>FEEDBACK</b></p> <pre>~nn@HDCP-STAT_&lt;io_mode&gt;,&lt;in_index&gt;,&lt;status&gt;&lt;CR&gt;&lt;LF&gt;</pre>	<p><b>io_mode</b> – Input/Output</p> <ul style="list-style-type: none"> <li>0 – Input</li> <li>1 – Output</li> </ul> <p><b>in_index</b> – Number that indicates the specific number of inputs or outputs (based on <code>io_mode</code>):</p> <ul style="list-style-type: none"> <li>1-4</li> </ul> <p><b>status</b> – Signal encryption status - valid values On/Off</p> <ul style="list-style-type: none"> <li>0 – HDCP Off</li> <li>1 – HDCP On</li> </ul>	<p>Get the output HDCP-STATUS of IN 1:</p> <pre>#HDCP-STAT?_0,1&lt;CR&gt;</pre>
HELP	<p>Get command list or help for specific command.</p>	<p><b>COMMAND</b></p> <pre>#HELP&lt;CR&gt;</pre> <pre>#HELP_&lt;cmd_name&gt;&lt;CR&gt;</pre> <p><b>FEEDBACK</b></p> <pre>1. Multi-line: ~nn@Device_&lt;cmd_name&gt;,&lt;cmd_name...&gt;&lt;CR&gt;&lt;LF&gt;</pre> <p>To get help for command use: <code>HELP (COMMAND_NAME)&lt;CR&gt;&lt;LF&gt;</code></p> <pre>~nn@HELP_&lt;cmd_name&gt;:&lt;CR&gt;&lt;LF&gt;</pre> <pre>description&lt;CR&gt;&lt;LF&gt;</pre> <pre>USAGE: usage&lt;CR&gt;&lt;LF&gt;</pre>	<p><b>cmd_name</b> – Name of a specific command</p>	<p>Get the command list:</p> <pre>#HELP&lt;CR&gt;</pre> <p>To get help for AV-SW-TIMEOUT:</p> <pre>HELP_av-sw-timeout&lt;CR&gt;</pre>



Function	Description	Syntax	Parameters/Attributes	Example												
<b>LABEL</b>	Set input/output label.	<b>COMMAND</b> #LABEL_ <i>io_mode</i> , <i>io_index</i> , <i>switch</i> , <i>label_txt</i> <CR> <b>FEEDBACK</b> ~nn@LABEL_ <i>io_mode</i> , <i>io_index</i> , <i>switch</i> , <i>label_txt</i> <CR><LF>	<i>io_mode</i> – Input/Output 0 – Input 1 – Output <i>io_index</i> – Number that indicates the specific input or output port: 1-4 <i>switch</i> – On/Off (enable/disable) custom label <i>label_txt</i> – Custom label string	Set input label for HDMI 3: #LABEL_0,3,1,HDMI<CR>												
<b>LABEL?</b>	Get input/output label.	<b>COMMAND</b> #LABEL?_ <i>io_mode</i> , <i>io_index</i> <CR> <b>FEEDBACK</b> ~nn@LABEL_ <i>io_mode</i> , <i>io_index</i> , <i>switch</i> , <i>label_txt</i> <CR><LF>	<i>io_mode</i> – Input/Output 0 – Input 1 – Output <i>io_index</i> – Number that indicates the specific input or output port: 1-4 <i>switch</i> – On/Off (enable/disable) custom label <i>label_txt</i> – Custom label string	Get output label for HDMI 3: #LABEL?_1,3<CR>												
<b>LABEL-CFG</b>	Set Label Config for output.	<b>COMMAND</b> #LABEL- CFG_ <i>io_mode</i> , <i>io_index</i> , <i>foregnd_color</i> , <i>backgnd_stat</i> , <i>position</i> <CR> <b>FEEDBACK</b> ~nn@LABEL- CFG_ <i>io_mode</i> , <i>io_index</i> , <i>foregnd_color</i> , <i>backgnd_stat</i> , <i>position</i> <CR><LF>	<i>io_mode</i> – 0 – Input 1 – Output <i>io_index</i> – Number that indicates the specific input or output port: 1-4 <b>foregnd_color:</b> 0 – White 1 – Black 2 – Green 3 – Purple <b>backgnd_stat</b> – 0 – Off 1 – On <b>position</b> – 0 – Top Left 1 – Top Right 2 – Bottom Left 3 – Bottom Right	Set HDMI 1 output label configuration to green on top left side of screen: #LABEL- CFG_1,1,2,1,0<CR>												
<b>LABEL-CFG?</b>	Get Label Config for output.	<b>COMMAND</b> #LABEL-CFG?_ <i>io_mode</i> , <i>io_index</i> <CR> <b>FEEDBACK</b> ~nn@LABEL- CFG_ <i>io_mode</i> , <i>io_index</i> , <i>foregnd_color</i> , <i>backgnd_ena</i> , <i>position</i> <CR><LF>	<i>io_mode</i> – 0 – Input 1 – Output <i>io_index</i> – Number that indicates the specific input or output port: 1-4 <b>foregnd_color:</b> 0 – White 1 – Black 2 – Green 3 – Purple <b>backgnd_stat</b> – 0 – Off 1 – On <b>position</b> – 0 – Top Left 1 – Top Right 2 – Bottom Left 3 – Bottom Right	Get HDMI 1 output label configuration: #LABEL-CFG?_1,1<CR>												
<b>LDEDID</b>	Write EDID data from external application to device. <p>① When the unit receives the LDEDID command it replies with READY and enters the special EDID packet wait mode. In this mode the unit can receive only packets and not regular protocol commands.</p> <p>If the unit does not receive correct packets for 30 seconds or is interrupted for more than 30 seconds before receiving all packets, it sends timeout error ~nn@LDEDID_err01&lt;CR&gt;&lt;LF&gt; and returns to the regular protocol mode. If the unit received data that is not a correct packet, it sends the corresponding error and returns to the regular protocol mode.</p>	<b>COMMAND</b> Multi-step syntax <b>FEEDBACK</b> Step 1: #LDEDID_ <i>edid_io</i> , <i>dest_bitmask</i> , <i>edid_size</i> , <i>safe_mode</i> <CR> Response 1: ~nn@LDEDID_ <i>edid_io</i> , <i>dest_bitmask</i> , <i>edid_size</i> , <i>safe_mode</i> , <i>read_y</i> <CR><LF> or ~nn@LDEDID_errnn<CR><LF> Step 2: If ready was received, send EDID_DATA Response 2: ~nn@LDEDID_ <i>edid_io</i> , <i>dest_bitmask</i> , <i>edid_size</i> , <i>safe_mode</i> , <i>ok</i> <CR><LF> or ~nn@LDEDID_errnn<CR><LF>	<i>edid_io</i> – EDID destination type (usually input) 0 – Input 1 – Output 2 – Default EDID 3 – Custom EDID <b>dest_bitmask</b> – Bitmap representing destination IDs. Format: 0x*****, where * is ASCII presentation of hex digit. The binary presentation of this number is a bit mask for destinations. Setting '1' means EDID data has to be copied to this destination <i>edid_size</i> – EDID data size <b>safe_mode</b> – Safe mode 0 – Device accepts the EDID as is without trying to adjust 1 – Device tries to adjust the EDID <b>edid_data</b> – Data in protocol packets <b>Using the Packet Protocol</b> Send a command: LDRV, LOAD, IROUT, LDEDID Receive Ready or ERR### If Ready: a. Send a packet, b. Receive OK on the last packet. c. Receive OK for the command Packet structure: <b>Packet ID</b> (1, 2, 3...) (2 bytes in length) <b>Length</b> (data length + 2 for CRC) – (2 bytes in length) <b>Data</b> (data length - 2 bytes) <b>CRC</b> – 2 bytes <table border="1" style="margin-left: 20px;"> <tr> <td>01</td> <td>02</td> <td>03</td> <td>04</td> <td>05</td> <td></td> </tr> <tr> <td>Packet ID</td> <td>Length</td> <td>Data</td> <td>CRC</td> <td></td> <td></td> </tr> </table> 5. Response: ~nnnn_ok<CR><LF> (Where <b>NNNN</b> is the received packet ID in ASCII hex digits.)	01	02	03	04	05		Packet ID	Length	Data	CRC			Write the EDID data from an external application to the HDMI In 1 input without adjustment attempts: #LDEDID_0,0x1,2340,0<CR> Write the EDID data from an external application to HDMI In 1 and PC In inputs with adjustment attempts: #LDEDID_0,0x5,2340,1<CR>
01	02	03	04	05												
Packet ID	Length	Data	CRC													

Function	Description	Syntax	Parameters/Attributes	Example
LOCK-EDID	Lock last read EDID.	<b>COMMAND</b> #LOCK-EDID_ <u>in_index</u> ,lock_mode<CR> <b>FEEDBACK</b> ~nn@LOCK-EDID_ <u>in_index</u> ,lock_mode<CR><LF>	<b>in_index</b> – Number that indicates the specific input: 1-4 <b>lock_mode</b> – On/Off 0 – Off unlocks EDID 1 – On locks EDID	Lock the last read EDID from the HDMI In 2 input: #LOCK-EDID_2,1<CR>
LOCK-EDID?	Get EDID lock state.	<b>COMMAND</b> #LOCK-EDID?_ <u>in_index</u> ,<CR> <b>FEEDBACK</b> ~nn@LOCK-EDID_ <u>in_index</u> ,lock_mode<CR><LF>	<b>in_index</b> – Number that indicates the specific input: 1-4 <b>lock_mode</b> – On/Off 0 – Off unlocks EDID 1 – On locks EDID	Get EDID lock state for Input 2: #LOCK-EDID?_2<CR>
LOCK-FP	Lock the front panel.	<b>COMMAND</b> #LOCK-FP_ <u>lock/unlock</u> <CR> <b>FEEDBACK</b> ~nn@LOCK-FP_ <u>lock/unlock</u> <CR><LF>	<b>lock/unlock</b> – On/Off 0 – Off unlocks front panel buttons or keyboard 1 – On locks front panel buttons or keyboard	Unlock front panel: #LOCK-FP_0<CR>
LOCK-FP?	Get the front panel lock state.	<b>COMMAND</b> #LOCK-FP?_ <u>lock/unlock</u> <CR> <b>FEEDBACK</b> ~nn@LOCK-FP_ <u>lock/unlock</u> <CR><LF>	<b>lock/unlock</b> – On/Off 0 – Off unlocks front panel buttons or keyboard 1 – On locks front panel buttons or keyboard	Get the front panel lock state: #LOCK-FP?<CR>
LOGIN (internal)	Set protocol permission.  ① The permission system works only if security is enabled with the "SECUR" command.  LOGIN allows the user to run commands with an End User or Administrator permission level. When the permission system is enabled, LOGIN enables running commands with the User or Administrator permission level. When set, login must be performed upon each connection.  It is not mandatory to enable the permission system in order to use the device.  In each device, some connections allow logging in to different levels. Some do not work with security at all.  Connection may logout after timeout.	<b>COMMAND</b> #LOGIN_ <u>login_level</u> ,password<CR> <b>FEEDBACK</b> ~nn@LOGIN_ <u>login_level</u> ,password_ok<CR><LF> or ~nn@LOGIN_ <u>err_004</u> <CR><LF> (if bad password entered)	<b>login_level</b> – Level of permissions required (User or Admin) <b>password</b> – Predefined password (by PASS command). Default password is an empty string	Set the protocol permission level to Admin (when the password defined in the PASS command is 33333): #LOGIN_admin,33333<CR>
LOGIN? (internal)	Get current protocol permission level.  ① The permission system works only if security is enabled with the "SECUR" command.  For devices that support security, LOGIN allows the user to run commands with an End User or Administrator permission level.  In each device, some connections allow logging in to different levels. Some do not work with security at all.  Connection may logout after timeout.	<b>COMMAND</b> #LOGIN?_ <u>login_level</u> <CR> <b>FEEDBACK</b> ~nn@LOGIN_ <u>login_level</u> <CR><LF>	<b>login_level</b> – Level of permissions required (User or Admin)	Get current protocol permission level: #LOGIN?<CR>
LOGOUT (internal)	Cancel current permission level.  ① Logs out from End User or Administrator permission levels to Not Secure.	<b>COMMAND</b> #LOGOUT<CR> <b>FEEDBACK</b> ~nn@LOGOUT_ <u>ok</u> <CR><LF>		#LOGOUT<CR>

Function	Description	Syntax	Parameters/Attributes	Example
MODEL?	Get device model.  ① This command identifies equipment connected to VSM-4x4x and notifies of identity changes to the connected equipment. The Matrix saves this data in memory to answer REMOTE-INFO requests.	<b>COMMAND</b> #MODEL?_<CR> <b>FEEDBACK</b> ~nn@MODEL_<model_name><CR><LF>	<b>model_name</b> – String of up to 19 printable ASCII chars	Get the device model: #MODEL?_<CR>
MUTE	Set audio mute.	<b>COMMAND</b> #MUTE_<out_index>,<mute_mode><CR> <b>FEEDBACK</b> ~nn@MUTE_<out_index>,<mute_mode><CR><LF>	<b>out_index</b> – Number that indicates the specific output: 1-4 <b>mute_mode</b> – On/Off 0 – Off 1 – On	Set Output 1 to mute: #MUTE_1,1<CR>
MUTE?	Get audio mute.	<b>COMMAND</b> #MUTE?_<out_index><CR> <b>FEEDBACK</b> ~nn@MUTE_<out_index>,<mute_mode><CR><LF>	<b>out_index</b> – Number that indicates the specific output: 1-4 <b>mute_mode</b> – On/Off 0 – Off 1 – On	Get mute status of output 1 #MUTE_1?<CR>
NAME	Set machine (DNS) name.  ① The machine name is not the same as the model name. The machine name is used to identify a specific machine or a network in use (with DNS feature on).	<b>COMMAND</b> #NAME_<machine_name><CR> <b>FEEDBACK</b> ~nn@NAME_<machine_name><CR><LF>	<b>machine_name</b> – String of up to 15 alpha-numeric chars (can include hyphen, not at the beginning or end)	Set the DNS name of the device to room-442: #NAME_<room-442><CR>
NAME?	Get machine (DNS) name.  ① The machine name is not the same as the model name. The machine name is used to identify a specific machine or a network in use (with DNS feature on).	<b>COMMAND</b> #NAME?_<CR> <b>FEEDBACK</b> ~nn@NAME_<machine_name><CR><LF>	<b>machine_name</b> – String of up to 15 alpha-numeric chars (can include hyphen, not at the beginning or end)	Get the DNS name of the device: #NAME?_<CR>
NAME-RST	Reset machine (DNS) name to factory default.  ① Factory default of machine (DNS) name is "KRAME" + 4 last digits of device serial number.	<b>COMMAND</b> #NAME-RST<CR> <b>FEEDBACK</b> ~nn@NAME-RST_<ok><CR><LF>		Reset the machine name (S/N last digits are 0102): #NAME-RST_<kramer_0102><CR>
NET-CONFIG	Set a network configuration.  ① Parameters [DNS1] and [DNS2] are optional.  ② For Backward compatibility, the <b>id</b> parameter can be omitted. In this case, the Network ID, by default, is 0, which is the Ethernet control port.  ③ If the gateway address is not compliant to the subnet mask used for the host IP, the command will return an error. Subnet and gateway compliancy specified by RFC950.	<b>COMMAND</b> #NET-CONFIG_<netw_id>,<net_ip>,<net_mask>,<gateway>,[<dns1>],[<dns2>]<CR> <b>FEEDBACK</b> ~nn@NET-CONFIG_<netw_id>,<net_ip>,<net_mask>,<gateway><CR><LF>	<b>netw_id</b> – Network ID—the device network interface (if there are more than one). Counting is 0 based, meaning the control port is '0', additional ports are 1,2,3.... <b>net_ip</b> – Network IP <b>net_mask</b> – Network mask <b>gateway</b> – Network gateway	Set the device network parameters to IP address 192.168.113.10, net mask 255.255.0.0, and gateway 192.168.0.1: #NET-CONFIG_0,192.168.113.10,255.255.0.0,192.168.0.1<CR>
NET-CONFIG?	Get a network configuration.	<b>COMMAND</b> #NET-CONFIG?_<netw_id><CR> <b>FEEDBACK</b> ~nn@NET-CONFIG_<netw_id>,<net_ip>,<net_mask>,<gateway><CR><LF>	<b>netw_id</b> – Network ID—the device network interface (if there are more than one). Counting is 0 based, meaning the control port is '0', additional ports are 1,2,3.... <b>net_ip</b> – Network IP <b>net_mask</b> – Network mask <b>gateway</b> – Network gateway	Get network configuration: #NET-CONFIG?_<id><CR>

Function	Description	Syntax	Parameters/Attributes	Example
NET-DHCP	<p>Set DHCP mode.</p> <p>① Only 1 is relevant for the mode value. To disable DHCP, the user must configure a static IP address for the device.</p> <p>Connecting Ethernet to devices with DHCP may take more time in some networks.</p> <p>To connect with a randomly assigned IP by DHCP, specify the device DNS name (if available) using the <b>NAME</b> command. You can also get an assigned IP by direct connection to USB or RS-232 protocol port, if available.</p> <p>For proper settings consult your network administrator.</p> <p>① For Backward compatibility, the <b>id</b> parameter can be omitted. In this case, the Network ID, by default, is 0, which is the Ethernet control port.</p>	<p><b>COMMAND</b></p> <pre>#NET-DHCP_netw_id,dhcp_state&lt;CR&gt;</pre> <p><b>FEEDBACK</b></p> <pre>~nn@NET-DHCP_netw_id,dhcp_state&lt;CR&gt;&lt;LF&gt;</pre>	<p><b>netw_id</b> – Network ID—the device network interface (if there are more than one). Counting is 0 based, meaning the control port is '0', additional ports are 1,2,3....</p> <p><b>dhcp_state</b> –</p> <p>1 – Try to use DHCP. (If unavailable, use the IP address set by the factory or the <b>net-ip</b> command).</p>	<p>Enable DHCP mode for port 1, if available:</p> <pre>#NET-DHCP_1,1&lt;CR&gt;</pre>
NET-DHCP?	<p>Get DHCP mode.</p> <p>① For Backward compatibility, the <b>id</b> parameter can be omitted. In this case, the Network ID, by default, is 0, which is the Ethernet control port.</p>	<p><b>COMMAND</b></p> <pre>#NET-DHCP?_netw_id&lt;CR&gt;</pre> <p><b>FEEDBACK</b></p> <pre>~nn@NET-DHCP?_netw_id,dhcp_mode&lt;CR&gt;&lt;LF&gt;</pre>	<p><b>netw_id</b> – Network ID—the device network interface (if there are more than one). Counting is 0 based, meaning the control port is '0', additional ports are 1,2,3....</p> <p><b>dhcp_mode</b> –</p> <p>0 – Do not use DHCP. Use the IP set by the factory or using the <b>net-ip</b> or <b>net-config</b> command.</p> <p>1 – Try to use DHCP. If unavailable, use the IP set by the factory or using the <b>net-ip</b> or <b>net-config</b> command.</p>	<p>Get DHCP mode for port 1:</p> <pre>#NET-DHCP?_1&lt;CR&gt;</pre>
NET-GATE	<p>Set gateway IP.</p> <p>① A network gateway connects the device via another network and maybe over the Internet. Be careful of security issues. For proper settings consult your network administrator.</p>	<p><b>COMMAND</b></p> <pre>#NET-GATE_ip_address&lt;CR&gt;</pre> <p><b>FEEDBACK</b></p> <pre>~nn@NET-GATE_ip_address&lt;CR&gt;&lt;LF&gt;</pre>	<p><b>ip_address</b> – Format: xxx.xxx.xxx.xxx</p>	<p>Set the gateway IP address to 192.168.0.1:</p> <pre>#NET-GATE_192.168.000.001&lt;CR&gt;</pre>
NET-GATE?	<p>Get gateway IP.</p> <p>① A network gateway connects the device via another network and maybe over the Internet. Be aware of security problems.</p>	<p><b>COMMAND</b></p> <pre>#NET-GATE?_&lt;CR&gt;</pre> <p><b>FEEDBACK</b></p> <pre>~nn@NET-GATE_ip_address&lt;CR&gt;&lt;LF&gt;</pre>	<p><b>ip_address</b> – Format: xxx.xxx.xxx.xxx</p>	<p>Get the gateway IP address:</p> <pre>#NET-GATE?_&lt;CR&gt;</pre>
NET-IP	<p>Set IP address.</p> <p>① For proper settings consult your network administrator.</p>	<p><b>COMMAND</b></p> <pre>#NET-IP_ip_address&lt;CR&gt;</pre> <p><b>FEEDBACK</b></p> <pre>~nn@NET-IP_ip_address&lt;CR&gt;&lt;LF&gt;</pre>	<p><b>ip_address</b> – Format: xxx.xxx.xxx.xxx</p>	<p>Set the IP address to 192.168.1.39:</p> <pre>#NET-IP_192.168.001.039&lt;CR&gt;</pre>
NET-IP?	<p>Get IP address.</p>	<p><b>COMMAND</b></p> <pre>#NET-IP?_&lt;CR&gt;</pre> <p><b>FEEDBACK</b></p> <pre>~nn@NET-IP_ip_address&lt;CR&gt;&lt;LF&gt;</pre>	<p><b>ip_address</b> – Format: xxx.xxx.xxx.xxx</p>	<p>Get the IP address:</p> <pre>#NET-IP?_&lt;CR&gt;</pre>
NET-MAC?	<p>Get MAC address.</p> <p>① For backward compatibility, the <b>id</b> parameter can be omitted. In this case, the Network ID, by default, is 0, which is the Ethernet control port.</p>	<p><b>COMMAND</b></p> <pre>#NET-MAC?_id&lt;CR&gt;</pre> <p><b>FEEDBACK</b></p> <pre>~nn@NET-MAC_id,mac_address&lt;CR&gt;&lt;LF&gt;</pre>	<p><b>id</b> – Network ID—the device network interface (if there are more than one). Counting is 0 based, meaning the control port is '0', additional ports are 1,2,3....</p> <p><b>mac_address</b> – Unique MAC address. Format: XX-XX-XX-XX-XX-XX where X is hex digit</p>	<pre>#NET-MAC?_id&lt;CR&gt;</pre>
NET-MASK	<p>Set subnet mask.</p> <p>① For proper settings consult your network administrator.</p>	<p><b>COMMAND</b></p> <pre>#NET-MASK_net_mask&lt;CR&gt;</pre> <p><b>FEEDBACK</b></p> <pre>~nn@NET-MASK_net_mask&lt;CR&gt;&lt;LF&gt;</pre>	<p><b>net_mask</b> – Format: xxx.xxx.xxx.xxx</p>	<p>Set the subnet mask to 255.255.0.0:</p> <pre>#NET-MASK_255.255.000.000&lt;CR&gt;</pre>
NET-MASK?	<p>Get subnet mask.</p>	<p><b>COMMAND</b></p> <pre>#NET-MASK?_&lt;CR&gt;</pre> <p><b>FEEDBACK</b></p> <pre>~nn@NET-MASK_net_mask&lt;CR&gt;&lt;LF&gt;</pre>	<p><b>net_mask</b> – Format: xxx.xxx.xxx.xxx</p>	<p>Get the subnet mask:</p> <pre>#NET-MASK?&lt;CR&gt;</pre>

Function	Description	Syntax	Parameters/Attributes	Example
PASS	Set password for login level.	<b>COMMAND</b> #PASS_<login_level>,password<CR> <b>FEEDBACK</b> ~nn@PASS_<login_level>,password<CR><LF>	login_level – Level of login to set (End User or Administrator). password – Password for the login_level. Up to 15 printable ASCII chars	Set the password for the Admin protocol permission level to 33333: #PASS_admin,33333<CR>
PASS?	Get password for login level.	<b>COMMAND</b> #PASS?_<login_level><CR> <b>FEEDBACK</b> ~nn@PASS_<login_level>,password<CR><LF>	login_level – Level of login to set (End User or Administrator). password – Password for the login_level. Up to 15 printable ASCII chars	Get the password for the Admin protocol permission level: #PASS?_admin<CR>
PROT-VER?	Get device protocol version.	<b>COMMAND</b> #PROT-VER?_<CR> <b>FEEDBACK</b> ~nn@PROT-VER_3000:version<CR><LF>	version – XX.XX where X is a decimal digit	Get the device protocol version: #PROT-VER?_<CR>
RESET	Reset device	<b>COMMAND</b> #RESET<CR> <b>FEEDBACK</b> ~nn@RESET_ok<CR><LF>		Reset the device: #RESET<CR>
ROUTE	Set layer routing.  ⓘ This command replaces all other routing commands.	<b>COMMAND</b> #ROUTE_<layer_type>,out_index,in_index<CR> <b>FEEDBACK</b> ~nn@ROUTE_<layer_type>,out_index<CR><LF>	layer_type Layer Enumeration 1 – Video 2 – Audio out_index 1 – OUT 1 HDMI 2 – OUT 2 HDBT 3 – OUT 3 HDBT 4 – OUT 4 HDBT in_index – Source id 1 – IN 1 2 – IN 2 3 – IN 3 4 – IN 4	Route video IN 2 to video OUT 4: #ROUTE_1,4,2<CR>
ROUTE?	Get layer routing.  ⓘ This command replaces all other routing commands.	<b>COMMAND</b> #ROUTE?_<layer_type>,out_index<CR> <b>FEEDBACK</b> ~nn@ROUTE_<layer_type>,out_index,in_index<CR><LF>	layer_type Layer Enumeration 1 – Video 2 – Audio out_index 1 – OUT 1 HDMI 2 – OUT 2 HDBT 3 – OUT 3 HDBT 4 – OUT 4 HDBT in_index – Source id 1 – IN 1 2 – IN 2 3 – IN 3 4 – IN 4	Get the layer routing: #ROUTE?_<layer>,dest<CR> >
SECUR	Start/stop security.  ⓘ The permission system works only if security is enabled with the "SECUR" command.	<b>COMMAND</b> #SECUR_security_state<CR> <b>FEEDBACK</b> ~nn@SECUR_security_state<CR><LF>	security_state – Security state 0 – OFF (disables security) 1 – ON (enables security)	Enable the permission system: #SECUR_0<CR>
SECUR?	Get current security state.  ⓘ The permission system works only if security is enabled with the "SECUR" command.	<b>COMMAND</b> #SECUR?_<CR> <b>FEEDBACK</b> ~nn@SECUR_security_state<CR><LF>	security_state – Security state 0 – OFF (disables security) 1 – ON (enables security)	Get current security state: #SECUR?_<CR>
SIGNAL?	Get input signal status.	<b>COMMAND</b> #SIGNAL?_<in_index><CR> <b>FEEDBACK</b> ~nn@SIGNAL_<in_index>,status<CR><LF>	in_index – Number that indicates the specific input: 1-4 status – Signal status according to signal validation: 0 – Off 1 – On	Get the input signal lock status of IN 1: #SIGNAL?_1<CR>
SN?	Get device serial number.	<b>COMMAND</b> #SN?_<CR> <b>FEEDBACK</b> ~nn@SN_serial_num<CR><LF>	serial_num – 14 decimal digits, factory assigned	Get the device serial number: #SN?_<CR>
VERSION?	Get firmware version number.	<b>COMMAND</b> #VERSION?_<CR> <b>FEEDBACK</b> ~nn@VERSION_<firmware_version><CR><LF>	firmware_version – XX.XX.XXXX where the digit groups are: major.minor.build version	Get the device firmware version number: #VERSION?_<CR>

Function	Description	Syntax	Parameters/Attributes	Example
VID-RES	<p>Set output resolution.</p> <p>① "Set" command with is_native=ON sets native resolution on selected output (resolution index sent = 0). Device sends as answer actual VIC ID of native resolution.</p> <p>To use "custom resolutions" (entries 100-105 In View Modes), define them using the DEF-RES command.</p>	<p><b>COMMAND</b></p> <pre>#VID-RES,&lt;u&gt;io_mode,io_index,is_native,resolution&lt;CR&gt;</pre> <p><b>FEEDBACK</b></p> <pre>~nn@VID-RES,&lt;u&gt;io_mode,io_index,is_native,resolution&lt;CR&gt;&lt;LF&gt;</pre>	<p><b>io_mode</b> – Input/Output</p> <p>0 – Input</p> <p>1 – Output</p> <p><b>io_index</b> – Number that indicates the specific input or output port:</p> <p>1-N (N= the total number of input or output ports)</p> <p><b>is_native</b> – Native resolution flag</p> <p>0 – Off</p> <p>1 – On</p> <p><b>resolution</b> – Resolution index</p> <p>4=1280x720p@60Hz</p> <p>5=1920x1080i@59.94Hz/60Hz</p> <p>16=1920x1080p@59.94Hz/60Hz</p> <p>19=1280x720p@50Hz</p> <p>31=1920x1080p@50Hz</p> <p>32=1920x1080p@23.97Hz/24Hz</p> <p>33=1920x1080p@25Hz</p> <p>34=1920x1080p@29.97Hz/30Hz</p> <p>60=1280x720p@23.97Hz/24Hz</p> <p>61=1280x720p@25Hz</p> <p>62=1280x720p@29.97Hz/30Hz</p> <p>66=1024x768@60Hz</p> <p>67=1280x768p@60Hz</p> <p>68=1280x1024p@60Hz</p> <p>69=1600x1200p@60Hz</p> <p>70=1680x1050p@60Hz</p> <p>71=1920x1200@60Hz</p> <p>72=3840x2160p@24Hz</p> <p>73=3840x2160p@25Hz</p> <p>74=3840x2160p@30Hz</p> <p>75=3840x2160p@50Hz</p> <p>76=3840x2160p@60Hz</p> <p>77=1366x768p@60</p> <p>78=1360x768p@60</p> <p>79=2560x1440p@60</p> <p>80=2560x1600p@60</p>	<p>Set output 1 resolution to 1280x720p@50Hz:</p> <pre>#VID-RES,1,1,1,19&lt;CR&gt;</pre>
VID-RES?	<p>Get output resolution.</p> <p>① "Get" command with is_native=ON returns native resolution VIC, with is_native=OFF returns current resolution.</p> <p>To use "custom resolutions" (entries 100-105 In View Modes), define them using the DEF-RES command.</p>	<p><b>COMMAND</b></p> <pre>#VID-RES?,&lt;u&gt;io_mode,io_index,is_native&lt;CR&gt;</pre> <p><b>FEEDBACK</b></p> <pre>~nn@VID-RES?,&lt;u&gt;io_mode,io_index,is_native,resolution&lt;CR&gt;&lt;LF&gt;</pre>	<p><b>io_mode</b> – Input/Output</p> <p>0 – Input</p> <p>1 – Output</p> <p><b>io_index</b> – Number that indicates the specific input or output port:</p> <p>1-N (N= the total number of input or output ports)</p> <p><b>is_native</b> – Native resolution flag</p> <p>0 – Off</p> <p>1 – On</p> <p><b>resolution</b> – Resolution index</p> <p>4=1280x720p@60Hz</p> <p>5=1920x1080i@59.94Hz/60Hz</p> <p>16=1920x1080p@59.94Hz/60Hz</p> <p>19=1280x720p@50Hz</p> <p>31=1920x1080p@50Hz</p> <p>32=1920x1080p@23.97Hz/24Hz</p> <p>33=1920x1080p@25Hz</p> <p>34=1920x1080p@29.97Hz/30Hz</p> <p>60=1280x720p@23.97Hz/24Hz</p> <p>61=1280x720p@25Hz</p> <p>62=1280x720p@29.97Hz/30Hz</p> <p>66=1024x768@60Hz</p> <p>67=1280x768p@60Hz</p> <p>68=1280x1024p@60Hz</p> <p>69=1600x1200p@60Hz</p> <p>70=1680x1050p@60Hz</p> <p>71=1920x1200@60Hz</p> <p>72=3840x2160p@24Hz</p> <p>73=3840x2160p@25Hz</p> <p>74=3840x2160p@30Hz</p> <p>75=3840x2160p@50Hz</p> <p>76=3840x2160p@60Hz</p> <p>77=1366x768p@60</p> <p>78=1360x768p@60</p> <p>79=2560x1440p@60</p> <p>80=2560x1600p@60</p>	<p>Set output resolution:</p> <pre>#VID-RES?,1,1,1,1&lt;CR&gt;</pre>
VIEW-MOD	<p>Set view mode.</p>	<p><b>COMMAND</b></p> <pre>#VIEW-MOD,&lt;u&gt;mode&lt;CR&gt;</pre> <p><b>FEEDBACK</b></p> <pre>~nn@VIEW-MOD,&lt;u&gt;mode&lt;CR&gt;&lt;LF&gt;</pre>	<p><b>mode</b> – View Modes</p> <p>0 – Matrix (Indep. switching)</p> <p>1 – PIP1</p> <p>3 – Quad</p> <p>4 – Video Wall (2x2)</p> <p>5 – POP3 (side)</p> <p>6 – Video Wall (1x4)</p> <p>7 – Split Screen</p> <p>8 – Side by Side</p> <p>9 – PIP2</p> <p>10 – PIP3</p> <p>11 – Stacked</p> <p>12 – POP3 (bottom)</p> <p>13 – Matrix (Fast switching)</p>	<p>Set view mode to PIP 1:</p> <pre>#VIEW-MOD,1&lt;CR&gt;</pre>
VIEW-MOD?	<p>Get view mode.</p>	<p><b>COMMAND</b></p> <pre>#VIEW-MOD?,&lt;u&gt;&lt;CR&gt;</pre> <p><b>FEEDBACK</b></p> <pre>~nn@VIEW-MOD,&lt;u&gt;mode&lt;CR&gt;&lt;LF&gt;</pre>	<p><b>mode</b> – View Modes</p> <p>0 – Matrix (Indep. switching)</p> <p>1 – PIP1</p> <p>3 – Quad</p> <p>4 – Video Wall (2x2)</p> <p>5 – POP3 (side)</p> <p>6 – Video Wall (1x4)</p> <p>7 – Split Screen</p> <p>8 – Side by Side</p> <p>9 – PIP2</p> <p>10 – PIP3</p> <p>11 – Stacked</p> <p>12 – POP3 (bottom)</p> <p>13 – Matrix (Fast switching)</p>	<p>Get view mode:</p> <pre>#VIEW-MOD?,&lt;u&gt;&lt;CR&gt;</pre>

Function	Description	Syntax	Parameters/Attributes	Example
VMUTE	Set enable/disable video on output.	<b>COMMAND</b> #VMUTE_out_index,flag<CR> <b>FEEDBACK</b> ~nn@VMUTE_out_index,flag<CR><LF>	<b>out_index</b> – Number that indicates the specific output: 1-N (N= the total number of outputs) <b>flag</b> – Video Mute 0 – Video enabled 1 – Video disabled 2 – Blank picture	Disable the video output on OUT 2: #VMUTE_2,0<CR>
VMUTE?	Get video on output status.	<b>COMMAND</b> #VMUTE?_out_index<CR> <b>FEEDBACK</b> ~nn@VMUTE_out_index,flag<CR><LF>	<b>out_index</b> – Number that indicates the specific output: 1-N (N= the total number of outputs) <b>flag</b> – Video Mute 0 – Video enabled 1 – Video disabled 2 – Blank picture	Get video on output status: #VMUTE?_2<CR>
WEB-ATTR	Set Web attributes values	<b>COMMAND</b> #WEB-ATTR_key,value<CR> <b>FEEDBACK</b> ~nn@WEB-ATTR_key,value<CR><LF>	<b>key</b> – Overlay order number <b>value</b> – Overlay order number	Set web attributes: #WEB-ATTR_1,1<CR>
WEB-ATTR?	Get Web attributes value.	<b>COMMAND</b> #WEB-ATTR?_key<CR> <b>FEEDBACK</b> ~nn@WEB-ATTR?_key,value<CR><LF>	<b>key</b> – Overlay order number <b>value</b> – Overlay order number	Get web attributes: #WEB-ATTR?_1<CR>
WND-ASPECT	Set window aspect ratio.	<b>COMMAND</b> #WND-ASPECT_mode,out_index,wind_id,aspect_ratio<CR> <b>FEEDBACK</b> ~nn@WND-ASPECT_mode,out_index,wind_id,aspect_ratio<CR><LF>	<b>mode</b> – the active mode: 0 – Matrix (Indep. switching) 1 – PIP1 3 – Quad 4 – Video Wall (2x2) 5 – POP3 (side) 6 – Video Wall (1x4) 7 – Split Screen 8 – Side by Side 9 – PIP2 10 – PIP3 11 – Stacked 12 – POP3 (bottom) 13 – Matrix (Fast switching) <b>out_index</b> – 0 – All <b>wind_id</b> – 0 – All 1 – Picture A 2 – Picture B 3 – Picture C 4 – Picture D <b>aspect_ratio</b> – 1 – Full 2 – Best fit	Set window aspect ratio to best fit in the quad mode: #WND-ASPECT_3,1,0,2<CR>
WND-ASPECT?	Get window aspect ratio.	<b>COMMAND</b> #WND-ASPECT?_mode,out_index,wind_id<CR> <b>FEEDBACK</b> ~nn@WND-ASPECT_mode,out_index,wind_id,aspect_ratio<CR><LF>	<b>mode</b> – the active mode: 0 – Matrix (Indep. switching) 1 – PIP1 3 – Quad 4 – Video Wall (2x2) 5 – POP3 (side) 6 – Video Wall (1x4) 7 – Split Screen 8 – Side by Side 9 – PIP2 10 – PIP3 11 – Stacked 12 – POP3 (bottom) 13 – Matrix (Fast switching) <b>out_index</b> – 0 – All <b>wind_id</b> – 0 – All 1 – Picture A 2 – Picture B 3 – Picture C 4 – Picture D <b>aspect_ratio</b> – 1 – Full 2 – Best fit	Get window aspect ratio in the quad mode: #WND-ASPECT?_3,0,0,0<CR>
WND-BEZEL	Set video wall bezel.	<b>COMMAND</b> #WND-BEZEL_mode,out_index,h_value,v_value,h_offset,v_offset<CR> <b>FEEDBACK</b> ~nn@WND-BEZEL_mode,out_index,h_value,v_value,h_offset,v_offset<CR><LF>	<b>mode</b> – the active mode: 4 – Video Wall (2x2) 6 – Video Wall (1x4) <b>out_index</b> – 0 <b>h_value</b> – 0-250 <b>v_value</b> – 0-250 <b>h_offset</b> – 0-125 <b>v_offset</b> – 0-125	Set 2x2 video wall bezel: #WND-BEZEL_4,0,20,20,20<CR>
WND-BEZEL?	Get video wall bezel.	<b>COMMAND</b> #WND-BEZEL?_mode,out_index <CR> <b>FEEDBACK</b> ~nn@WND-BEZEL_mode,out_index,h_value,v_value,h_offset,v_offset<CR><LF>	<b>mode</b> – the active mode: 4 – Video Wall (2x2) <b>out_index</b> – 0 <b>h_value</b> – 0-250 <b>v_value</b> – 0-250 <b>h_offset</b> – 0-125 <b>v_offset</b> – 0-125	Get 2x2 video wall bezel: #WND-BEZEL?_4,0<CR>

Function	Description	Syntax	Parameters/Attributes	Example
WND-BEZEL14	Set video wall bezel for 1x4.	<b>COMMAND</b> #WND-BEZEL14 <sub>u</sub> ,mode,out_index,u_value,m-value,l_offset,u_offset,m_offset,l_offset<CR> <b>FEEDBACK</b> ~nn@WND-BEZEL14 <sub>u</sub> ,mode,out_index,u_value,m-value,l_offset,u_offset,m_offset,l_offset<CR><LF>	mode – the active mode: 6 – Video Wall (1x4) out_index – 0 u_value – 0-100 m_value – 0-100 l_value – 0-100 u_offset – 0-100 m_offset – 0-100 l_offset – 0-100	Set 1x4 video wall bezel: #WND-BEZEL <sub>u</sub> 6,0,1,1,1,1,1,1<CR>
WND-BEZEL14?	Get video wall bezel for 1x4.	<b>COMMAND</b> #WND-BEZEL14? <sub>u</sub> ,mode,out_index <CR> <b>FEEDBACK</b> ~nn@WND-BEZEL14 <sub>u</sub> ,mode,out_index,u_value,m-value,l_offset,u_offset,m_offset,l_offset<CR><LF>	mode – the active mode: 6 – Video Wall (1x4) out_index – 0 u_value – 0-100 m_value – 0-100 l_value – 0-100 u_offset – 0-100 m_offset – 0-100 l_offset – 0-100	Get window position: #WND-BEZEL? <sub>u</sub> 1<CR>
WND-BORDER	Set window border.	<b>COMMAND</b> #WND-BORDER <sub>u</sub> ,mode,out_index,wind_id,enable_state<CR> <b>FEEDBACK</b> ~nn@WND-BORDER <sub>u</sub> ,mode,out_index,wind_id,enable_state<CR><LF>	mode – the active mode: 0 – Matrix (Indep. switching) 1 – PIP1 3 – Quad 4 – Video Wall (2x2) 5 – POP3 (side) 6 – Video Wall (1x4) 7 – Split Screen 8 – Side by Side 9 – PIP2 10 – PIP3 11 – Stacked 12 – POP3 (bottom) 13 – Matrix (Fast switching) out_index – 0 – All wind_id – 0 – All 1 – Picture A 2 – Picture B 3 – Picture C 4 – Picture D enable_state – 0 – Disable 1 – Enable	Enable/disable window border in matrix mode: #WND-BORDER <sub>u</sub> 0,0,0,1<CR>
WND-BORDER?	Get window border.	<b>COMMAND</b> #WND-BORDER? <sub>u</sub> ,mode,out_index,wind_id <CR> <b>FEEDBACK</b> ~nn@WND-BORDER <sub>u</sub> ,mode,out_index,wind_id,enable_state<CR><LF>	mode – the active mode: 0 – Matrix (Indep. switching) 1 – PIP1 3 – Quad 4 – Video Wall (2x2) 5 – POP3 (side) 6 – Video Wall (1x4) 7 – Split Screen 8 – Side by Side 9 – PIP2 10 – PIP3 11 – Stacked 12 – POP3 (bottom) 13 – Matrix (Fast switching) out_index – 0 – All wind_id – 0 – All 1 – Picture A 2 – Picture B 3 – Picture C 4 – Picture D enable_state – 0 – Disable 1 – Enable	Get window border status: #WND-BORDER? <sub>u</sub> 0,0,0,0<CR>



Function	Description	Syntax	Parameters/Attributes	Example
WND-BORDER-CFG	Set border configuration.	<b>COMMAND</b> #WND-BORDER-CFG <sub>mode,out_index,wind_id,color,width</sub> <CR> <b>FEEDBACK</b> ~nn@WND-BORDER-CFG <sub>mode,out_index,wind_id,color,width</sub> <CR><LF>	<b>mode</b> – the active mode: 0 – Matrix (Indep. switching) 1 – PIP1 3 – Quad 4 – Video Wall (2x2) 5 – POP3 (side) 6 – Video Wall (1x4) 7 – Split Screen 8 – Side by Side 9 – PIP2 10 – PIP3 11 – Stacked 12 – POP3 (bottom) 13 – Matrix (Fast switching) <b>out_index</b> – 0 – All <b>color</b> – 0 – White 1 – Black 2 – Green 3 – Purple 4 – Blue 5 – Red <b>width</b> – 0 – Narrow 1 – Wide	Set wide black window border on Matrix mode: #WND-BORDER-CFG <sub>0,0,1,1</sub> <CR>
WND-BORDER-CFG?	Get border configuration.	<b>COMMAND</b> #WND-BORDER-CFG? <sub>mode,out_index,wind_id</sub> <CR> <b>FEEDBACK</b> ~nn@WND-BORDER-CFG <sub>mode,out_index,wind_id,color,width</sub> <CR><LF>	<b>mode</b> – the active mode: 0 – Matrix (Indep. switching) 1 – PIP1 3 – Quad 4 – Video Wall (2x2) 5 – POP3 (side) 6 – Video Wall (1x4) 7 – Split Screen 8 – Side by Side 9 – PIP2 10 – PIP3 11 – Stacked 12 – POP3 (bottom) 13 – Matrix (Fast switching) <b>out_index</b> – 0 – All <b>color</b> – 0 – White 1 – Black 2 – Green 3 – Purple 4 – Blue 5 – Red <b>width</b> – 0 – Narrow 1 – Wide	Get window border status: #WND-BORDER-CFG? <sub>0,0</sub> <CR>
WND-CROP	Set window crop.	<b>COMMAND</b> #WND-CROP <sub>mode,out_index,crop_left,crop_right,crop_top,crop_bottom</sub> <CR> <b>FEEDBACK</b> ~nn@WND-CROP <sub>mode,out_index,crop_left,crop_right,crop_top,crop_bottom</sub> <CR><LF>	<b>mode</b> – the active mode: 0 – Matrix (Indep. switching) 1 – PIP1 3 – Quad 4 – Video Wall (2x2) 5 – POP3 (side) 6 – Video Wall (1x4) 7 – Split Screen 8 – Side by Side 9 – PIP2 10 – PIP3 11 – Stacked 12 – POP3 (bottom) 13 – Matrix (Fast switching) <b>out_index</b> – 1 - 4 <b>crop_left</b> – 0-400 <b>crop_right</b> – 0-400 <b>crop_top</b> – 0-400 <b>crop_bottom</b> – 0-400	Crop window 2 in Quad POP3 Side: #WND-CROP <sub>5,2,20,0,20,20</sub> <CR>
WND-CROP?	Get window border status.	<b>COMMAND</b> #WND-CROP? <sub>mode,out_index</sub> <CR> <b>FEEDBACK</b> ~nn@WND-CROP <sub>mode,out_index,crop_left,crop_right,crop_top,crop_bottom</sub> <CR><LF>	<b>mode</b> – the active mode: 0 – Matrix (Indep. switching) 1 – PIP1 3 – Quad 4 – Video Wall (2x2) 5 – POP3 (side) 6 – Video Wall (1x4) 7 – Split Screen 8 – Side by Side 9 – PIP2 10 – PIP3 11 – Stacked 12 – POP3 (bottom) 13 – Matrix (Fast switching) <b>out_index</b> – 1 - 4 <b>crop_left</b> – 0-400 <b>crop_right</b> – 0-400 <b>crop_top</b> – 0-400 <b>crop_bottom</b> – 0-400	Get window border status: #WND-CROP? <sub>5,2</sub> <CR>

Function	Description	Syntax	Parameters/Attributes	Example
WND-DEFAULT	Set default for window.	<b>COMMAND</b> <code>#WND-default_mode,wind_id&lt;CR&gt;</code> <b>FEEDBACK</b> <code>~nn@WND-default_mode,wind_id&lt;CR&gt;&lt;LF&gt;</code>	<b>mode</b> – the active mode: 0 – Matrix (Indep. switching) 1 – PIP1 3 – Quad 4 – Video Wall (2x2) 5 – POP3 (side) 6 – Video Wall (1x4) 7 – Split Screen 8 – Side by Side 9 – PIP2 10 – PIP3 11 – Stacked 12 – POP3 (bottom) 13 – Matrix (Fast switching) <b>wind_id</b> – Number that indicates the specific window (number of windows changes for each mode): 1 – Picture A 2 – Picture B 3 – Picture C 4 – Picture D	Set default for PIP1: <code>#WND-BRD_1,1&lt;CR&gt;</code>
WND-ENABLE	Set window enable status.	<b>COMMAND</b> <code>#WND-ENABLE_mode,out_index,wind_id,status&lt;CR&gt;</code> <b>FEEDBACK</b> <code>~nn@WND-ENABLE_mode,out_index,wind_id,status&lt;CR&gt;&lt;LF&gt;</code>	<b>mode</b> – the active mode: 0 – Matrix (Indep. switching) 1 – PIP1 3 – Quad 4 – Video Wall (2x2) 5 – POP3 (side) 6 – Video Wall (1x4) 7 – Split Screen 8 – Side by Side 9 – PIP2 10 – PIP3 11 – Stacked 12 – POP3 (bottom) 13 – Matrix (Fast switching) <b>out_index</b> – 0 <b>wind_id</b> – Number that indicates the specific window (number of windows changes for each mode): 0 – All 1 – Picture A 2 – Picture B 3 – Picture C 4 – Picture D <b>status</b> – 0 – Vide disabled 1 – Video enabled 2 – Blank picture	Set window A to disable in Quad mode: <code>#WND-ENABLE_3,0,1,0&lt;CR&gt;</code>
WND-ENABLE?	Get window enable status.	<b>COMMAND</b> <code>#WND-ENABLE?_mode,out_index,wind_id&lt;CR&gt;</code> <b>FEEDBACK</b> <code>~nn@WND-ENABLE_mode,out_index,wind_id,status&lt;CR&gt;&lt;LF&gt;</code>	<b>mode</b> – the active mode: 0 – Matrix (Indep. switching) 1 – PIP1 3 – Quad 4 – Video Wall (2x2) 5 – POP3 (side) 6 – Video Wall (1x4) 7 – Split Screen 8 – Side by Side 9 – PIP2 10 – PIP3 11 – Stacked 12 – POP3 (bottom) 13 – Matrix (Fast switching) <b>out_index</b> – 0 <b>wind_id</b> – Number that indicates the specific window (number of windows changes for each mode): 0 – All 1 – Picture A 2 – Picture B 3 – Picture C 4 – Picture D <b>status</b> – 1 – Vide disabled 1 – Video enabled 2 – Blank picture	Get window enable status: <code>#WND-ENABLE?_1,0&lt;CR&gt;</code>
WND-POS	Set window position.	<b>COMMAND</b> <code>#WND-POS_mode,out_index,wind_id,h_position,v_position&lt;CR&gt;</code> <b>FEEDBACK</b> <code>~nn@WND-POS_mode,out_index,wind_id,h_position,v_position&lt;CR&gt;&lt;LF&gt;</code>	<b>mode</b> – the active mode: 1 – PIP1 9 – PIP2 10 – PIP3 11 – Stacked <b>out_index</b> – 0 <b>wind_id</b> – Number that indicates the specific window (number of windows changes for each mode): 1 – Picture A (for Stacked) 2 – Picture B (for PIP1, PIP2, PIP3, Stacked) 3 – Picture C (for PIP2, PIP3, Stacked) 4 – Picture D (for PIP3, Stacked) <b>h_position</b> – 0-100 <b>v_position</b> – 0-100	Set window position for picture B in PIP1 (h=30, v=30): <code>#WND-POS_1,0,2,30,30&lt;CR&gt;</code>

Function	Description	Syntax	Parameters/Attributes	Example
WND-POS?	Get window border status.	<b>COMMAND</b> #WND-POS?_mode,out_index,wind_id<CR> <b>FEEDBACK</b> ~nn@WND-POS_mode,out_index,wind_id,h_position,v_position<CR><LF>	mode – the active mode: 1 – PIP1 9 – PIP2 10 – PIP3 11 – Stacked out_index – 0 wind_id – Number that indicates the specific window (number of windows changes for each mode): 1 – Picture A (for Stacked) 2 – Picture B (for PIP1, PIP2, PIP3, Stacked) 3 – Picture C (for PIP2, PIP3, Stacked) 4 – Picture D (for PIP3, Stacked) h_position – 0-100 v_position – 0-100	Get window position for PIP1 (Picture B): #WND-POS?_1,0,2<CR>
WND-SIZE	Set window size.	<b>COMMAND</b> #WND-SIZE_mode,out_index,wind_id,size<CR> <b>FEEDBACK</b> ~nn@WND-SIZE_mode,out_index,wind_id,size<CR><LF>	mode – the active mode: 1 – PIP1 9 – PIP2 10 – PIP3 11 – Stacked out_index – 0 wind_id – Number that indicates the specific window (number of windows changes for each mode): 1 – Picture A (for Stacked) 2 – Picture B (for PIP1, PIP2, PIP3, Stacked) 3 – Picture C (for PIP2, PIP3, Stacked) 4 – Picture D (for PIP3, Stacked) size – 0 – 1/2 1 – 1/4 2 – 1/9 3 – 1/16 4 – 1/25	Set window size for picture B in PIP1 to 1/2: #WND-SIZE_1,0,2,0<CR>
WND-SIZE?	Get window size.	<b>COMMAND</b> #WND-SIZE?_mode,out_index,wind_id<CR> <b>FEEDBACK</b> ~nn@WND-SIZE_mode,out_index,wind_id,size<CR><LF>	mode – the active mode: 1 – PIP1 9 – PIP2 10 – PIP3 11 – Stacked out_index – 0 wind_id – Number that indicates the specific window (number of windows changes for each mode): 1 – Picture A (for Stacked) 2 – Picture B (for PIP1, PIP2, PIP3, Stacked) 3 – Picture C (for PIP2, PIP3, Stacked) 4 – Picture D (for PIP3, Stacked) size – 0 – 1/2 1 – 1/4 2 – 1/9 3 – 1/16 4 – 1/25	Get window size for PIP1 (Picture B): #WND-SIZE?_1,0,2<CR>
WND-SPLIT	Set window split position.	<b>COMMAND</b> #WND-BRD_mode,out_index,wind_id,position<CR> <b>FEEDBACK</b> ~nn@WND-BRD_mode,out_index,wind_id,position<CR><LF>	mode – the active mode: 7 – Split screen 8 – Side by Side out_index – 0 wind_id – 0 position – 10 to 90 (in steps of 10)	set window split screen position to 30: #WND-POS_7,0,0,30<CR>
WND-SPLIT?	Get window split position.	<b>COMMAND</b> #WND-SPLIT?_mode,out_index,wind_id<CR> <b>FEEDBACK</b> ~nn@WND-SPLIT_mode,out_index,wind_id,position<CR><LF>	mode – the active mode: 7 – Split screen 8 – Side by Side out_index – 0 wind_id – 0 position – 10 to 90 (in steps of 10)	Get window split screen position: #WND-SPLIT?_7,0,0<CR>

Function	Description	Syntax	Parameters/Attributes	Example
WND-SRC	Set window source.	<b>COMMAND</b> <code>#WND-SRC<sub>u</sub>mode,layer_type,out_index,wind_id,in_index&lt;CR&gt;</code> <b>FEEDBACK</b> <code>~nn@WND-SRC<sub>u</sub>mode,layer_type,out_index,wind_id,in_index&lt;CR&gt;&lt;LF&gt;</code>	<b>mode</b> – The active mode: 0– Matrix (Indep. switching) 1– PIP1 3– Quad 4– Video Wall (2x2) 5– POP3 (side) 6– Video Wall (1x4) 7– Split Screen 8– Side by Side 9– PIP2 10 – PIP3 11 – Stacked 12 – POP3 (bottom) 13 – Matrix (Fast switching) <b>Layer_type</b> – 1 – Video 2 – Audio <b>out_index</b> – 0 <b>wind_id</b> – Number that indicates the specific window (number of windows changes for each mode): 1 – Picture A 2 – Picture B 3 – Picture C 4 – Picture D <b>In_index</b> – 1 – HDMI1 2 – HDMI2 3 – HDMI3 4 – HDMI4	Set window HDMI 2 video source for Picture A in quad mode: <code>WND-SRC<sub>u</sub>3,1,0,1,2&lt;CR&gt;</code>
WND-SRC?	Get window source.	<b>COMMAND</b> <code>#WND-SRC?<sub>u</sub>mode,layer_type,out_index,wind_id&lt;CR&gt;</code> <b>FEEDBACK</b> <code>~nn@WND-SRC<sub>u</sub>mode,layer_type,out_index,wind_id,in_index&lt;CR&gt;&lt;LF&gt;</code>	<b>mode</b> – The active mode: 0– Matrix (Indep. switching) 1– PIP1 3– Quad 4– Video Wall (2x2) 5– POP3 (side) 6– Video Wall (1x4) 7– Split Screen 8– Side by Side 9– PIP2 10 – PIP3 11 – Stacked 12 – POP3 (bottom) 13 – Matrix (Fast switching) <b>Layer_type</b> – 1 – Video 2 – Audio <b>out_index</b> – 0 <b>wind_id</b> – Number that indicates the specific window (number of windows changes for each mode): 1 – Picture A 2 – Picture B 3 – Picture C 4 – Picture D <b>In_index</b> – 1 – HDMI1 2 – HDMI2 3 – HDMI3 4 – HDMI4	Get window video source for Picture A in quad mode: <code>WND-SRC?<sub>u</sub>3,1,0,1&lt;CR&gt;</code>
WND-TRANSP	Set window transparency.	<b>COMMAND</b> <code>#WND-TRANSP<sub>u</sub>mode,out_index,wind_id,transp&lt;CR&gt;</code> <b>FEEDBACK</b> <code>~nn@WND-TRANSP<sub>u</sub>mode,out_index,wind_id,transp&lt;CR&gt;&lt;LF&gt;</code>	<b>mode</b> – The active mode: 1– PIP1 9– PIP2 10 – PIP3 11 – Stacked <b>out_index</b> – 0 <b>wind_id</b> – Number that indicates the specific window (number of windows changes for each mode): 1 – Picture A (for Stacked) 2 – Picture B (for PIP1, PIP2, PIP3, Stacked) 3 – Picture C (for PIP2, PIP3, Stacked) 4 – Picture D (for PIP3, Stacked) <b>transp</b> – 0 to100	Set window transparency for Picture B to 70: <code>WND-SRC<sub>u</sub>9,0,2,70&lt;CR&gt;</code>
WND-TRANSP?	Get window transparency.	<b>COMMAND</b> <code>#WND-TRANSP?<sub>u</sub>mode,out_index,wind_id&lt;CR&gt;</code> <b>FEEDBACK</b> <code>~nn@WND-TRANSP<sub>u</sub>mode,out_index,wind_id,transp&lt;CR&gt;&lt;LF&gt;</code>	<b>mode</b> – The active mode: 1– PIP1 9– PIP2 10 – PIP3 11 – Stacked <b>out_index</b> – 0 <b>wind_id</b> – Number that indicates the specific window (number of windows changes for each mode): 1 – Picture A (for Stacked) 2 – Picture B (for PIP1, PIP2, PIP3, Stacked) 3 – Picture C (for PIP2, PIP3, Stacked) 4 – Picture D (for PIP3, Stacked) <b>transp</b> – 0 to100	Get window transparency for video source for Picture A in quad mode: <code>WND-SRC?<sub>u</sub>3,1,0,1&lt;CR&gt;</code>

Function	Description	Syntax	Parameters/Attributes	Example
W-SATURATION	<p>Set image saturation per output.</p> <p><b>i</b> Value limits can vary for different devices.</p> <p>Value is a property of input connected to current output. Changing input source might cause changes in this value (refer device definitions).</p> <p>In devices that enable showing multiple outputs on one display – each in a separate window – this command relates only to the window associated with the output indicated in the out-index parameter.</p>	<p><b>COMMAND</b></p> <pre>#W-SATURATION_u,in_index,value&lt;CR&gt;</pre> <p><b>FEEDBACK</b></p> <pre>~nn@W-SATURATION_u,in_index,value&lt;CR&gt;&lt;LF&gt;</pre>	<p><b>in_index</b> – Number that indicates the specific input: 1-4</p> <p><b>value</b> – Saturation value (0-100)</p>	<p>Set saturation for input 1 to 50:</p> <pre>#W-SATURATION_u,1,50&lt;CR&gt;</pre>
W-SATURATION?	<p>Get image saturation per output.</p> <p><b>i</b> Value limits can vary for different devices.</p> <p>Value is a property of input connected to current output. Changing input source might cause changes in this value (refer device definitions).</p> <p>In devices that enable showing multiple outputs on one display – each in a separate window – this command relates only to the window associated with the output indicated in the out-index parameter.</p>	<p><b>COMMAND</b></p> <pre>#W-SATURATION?_u,in_index&lt;CR&gt;</pre> <p><b>FEEDBACK</b></p> <pre>~nn@W-SATURATION_u,in_index,value&lt;CR&gt;&lt;LF&gt;</pre>	<p><b>in_index</b> – Number that indicates the specific input: 1-4</p> <p><b>value</b> – Saturation value (0-100)</p>	<p>Get saturation for input 1:</p> <pre>#W-SATURATION?_u,1&lt;CR&gt;</pre>

## Result and Error Codes

### Syntax

In case of an error, the device responds with an error message. The error message syntax:

- **~NN@ERR XXX<CR><LF>** – when general error, no specific command
- **~NN@CMD ERR XXX<CR><LF>** – for specific command
- **NN** – machine number of device, default = 01
- **XXX** – error code

### Error Codes

Error Name	Error Code	Description
P3K_NO_ERROR	0	No error
ERR_PROTOCOL_SYNTAX	1	Protocol syntax
ERR_COMMAND_NOT_AVAILABLE	2	Command not available
ERR_PARAMETER_OUT_OF_RANGE	3	Parameter out of range
ERR_UNAUTHORIZED_ACCESS	4	Unauthorized access
ERR_INTERNAL_FW_ERROR	5	Internal FW error
ERR_BUSY	6	Protocol busy
ERR_WRONG_CRC	7	Wrong CRC
ERR_TIMEDOUT	8	Timeout
ERR_RESERVED	9	(Reserved)
ERR_FW_NOT_ENOUGH_SPACE	10	Not enough space for data (firmware, FPGA...)
ERR_FS_NOT_ENOUGH_SPACE	11	Not enough space – file system
ERR_FS_FILE_NOT_EXISTS	12	File does not exist
ERR_FS_FILE_CANT_CREATED	13	File can't be created
ERR_FS_FILE_CANT_OPEN	14	File can't open
ERR_FEATURE_NOT_SUPPORTED	15	Feature is not supported
ERR_RESERVED_2	16	(Reserved)
ERR_RESERVED_3	17	(Reserved)
ERR_RESERVED_4	18	(Reserved)
ERR_RESERVED_5	19	(Reserved)
ERR_RESERVED_6	20	(Reserved)
ERR_PACKET_CRC	21	Packet CRC error
ERR_PACKET_MISSED	22	Packet number isn't expected (missing packet)
ERR_PACKET_SIZE	23	Packet size is wrong
ERR_RESERVED_7	24	(Reserved)
ERR_RESERVED_8	25	(Reserved)
ERR_RESERVED_9	26	(Reserved)
ERR_RESERVED_10	27	(Reserved)
ERR_RESERVED_11	28	(Reserved)
ERR_RESERVED_12	29	(Reserved)
ERR_EDID_CORRUPTED	30	EDID corrupted
ERR_NON_LISTED	31	Device specific errors
ERR_SAME_CRC	32	File has the same CRC – not changed
ERR_WRONG_MODE	33	Wrong operation mode
ERR_NOT_CONFIGURED	34	Device/chip was not initialized

The warranty obligations of Kramer Electronics Inc. ("Kramer Electronics") for this product are limited to the terms set forth below:

### **What is Covered**

This limited warranty covers defects in materials and workmanship in this product.

### **What is Not Covered**

This limited warranty does not cover any damage, deterioration or malfunction resulting from any alteration, modification, improper or unreasonable use or maintenance, misuse, abuse, accident, neglect, exposure to excess moisture, fire, improper packing and shipping (such claims must be presented to the carrier), lightning, power surges, or other acts of nature. This limited warranty does not cover any damage, deterioration or malfunction resulting from the installation or removal of this product from any installation, any unauthorized tampering with this product, any repairs attempted by anyone unauthorized by Kramer Electronics to make such repairs, or any other cause which does not relate directly to a defect in materials and/or workmanship of this product. This limited warranty does not cover cartons, equipment enclosures, cables or accessories used in conjunction with this product.

Without limiting any other exclusion herein, Kramer Electronics does not warrant that the product covered hereby, including, without limitation, the technology and/or integrated circuit(s) included in the product, will not become obsolete or that such items are or will remain compatible with any other product or technology with which the product may be used.

### **How Long this Coverage Lasts**

The standard limited warranty for Kramer products is seven (7) years from the date of original purchase, with the following exceptions:

1. All Kramer VIA hardware products are covered by a standard three (3) year warranty for the VIA hardware and a standard three (3) year warranty for firmware and software updates; all Kramer VIA accessories, adapters, tags, and dongles are covered by a standard one (1) year warranty.
2. Kramer fiber optic cables, adapter-size fiber optic extenders, pluggable optical modules, active cables, cable retractors, ring mounted adapters, portable power chargers, Kramer speakers, and Kramer touch panels are covered by a standard one (1) year warranty. Kramer 7-inch touch panels purchased on or after April 1st, 2020 are covered by a standard two (2) year warranty.
3. All Kramer Calibre products, all Kramer Minicom digital signage products, all HighSecLabs products, all streaming, and all wireless products are covered by a standard three (3) year warranty.
4. All Sierra Video MultiViewers are covered by a standard five (5) year warranty.
5. Sierra switchers & control panels are covered by a standard seven (7) year warranty (excluding power supplies and fans that are covered for three (3) years).
6. K-Touch software is covered by a standard one (1) year warranty for software updates.
7. All Kramer passive cables are covered by a lifetime warranty.

### **Who is Covered**

Only the original purchaser of this product is covered under this limited warranty. This limited warranty is not transferable to subsequent purchasers or owners of this product.

### **What Kramer Electronics Will Do**

Kramer Electronics will, at its sole option, provide one of the following three remedies to whatever extent it shall deem necessary to satisfy a proper claim under this limited warranty:

1. Elect to repair or facilitate the repair of any defective parts within a reasonable period of time, free of any charge for the necessary parts and labor to complete the repair and restore this product to its proper operating condition. Kramer Electronics will also pay the shipping costs necessary to return this product once the repair is complete.
2. Replace this product with a direct replacement or with a similar product deemed by Kramer Electronics to perform substantially the same function as the original product. If a direct or similar replacement product is supplied, the original product's end warranty date remains unchanged and is transferred to the replacement product.
3. Issue a refund of the original purchase price less depreciation to be determined based on the age of the product at the time remedy is sought under this limited warranty.

### **What Kramer Electronics Will Not Do Under This Limited Warranty**

If this product is returned to Kramer Electronics or the authorized dealer from which it was purchased or any other party authorized to repair Kramer Electronics products, this product must be insured during shipment, with the insurance and shipping charges prepaid by you. If this product is returned uninsured, you assume all risks of loss or damage during shipment. Kramer Electronics will not be responsible for any costs related to the removal or re-installation of this product from or into any installation. Kramer Electronics will not be responsible for any costs related to any setting up this product, any adjustment of user controls or any programming required for a specific installation of this product.

### **How to Obtain a Remedy Under This Limited Warranty**

To obtain a remedy under this limited warranty, you must contact either the authorized Kramer Electronics reseller from whom you purchased this product or the Kramer Electronics office nearest you. For a list of authorized Kramer Electronics resellers and/or Kramer Electronics authorized service providers, visit our web site at [www.kramerav.com](http://www.kramerav.com) or contact the Kramer Electronics office nearest you.

In order to pursue any remedy under this limited warranty, you must possess an original, dated receipt as proof of purchase from an authorized Kramer Electronics reseller. If this product is returned under this limited warranty, a return authorization number, obtained from Kramer Electronics, will be required (RMA number). You may also be directed to an authorized reseller or a person authorized by Kramer Electronics to repair the product.

If it is decided that this product should be returned directly to Kramer Electronics, this product should be properly packed, preferably in the original carton, for shipping. Cartons not bearing a return authorization number will be refused.

### **Limitation of Liability**

THE MAXIMUM LIABILITY OF KRAMER ELECTRONICS UNDER THIS LIMITED WARRANTY SHALL NOT EXCEED THE ACTUAL PURCHASE PRICE PAID FOR THE PRODUCT. TO THE MAXIMUM EXTENT PERMITTED BY LAW, KRAMER ELECTRONICS IS NOT RESPONSIBLE FOR DIRECT, SPECIAL, INCIDENTAL OR CONSEQUENTIAL DAMAGES RESULTING FROM ANY BREACH OF WARRANTY OR CONDITION, OR UNDER ANY OTHER LEGAL THEORY. Some countries, districts or states do not allow the exclusion or limitation of relief, special, incidental, consequential or indirect damages, or the limitation of liability to specified amounts, so the above limitations or exclusions may not apply to you.

### **Exclusive Remedy**

TO THE MAXIMUM EXTENT PERMITTED BY LAW, THIS LIMITED WARRANTY AND THE REMEDIES SET FORTH ABOVE ARE EXCLUSIVE AND IN LIEU OF ALL OTHER WARRANTIES, REMEDIES AND CONDITIONS, WHETHER ORAL OR WRITTEN, EXPRESS OR IMPLIED. TO THE MAXIMUM EXTENT PERMITTED BY LAW, KRAMER ELECTRONICS SPECIFICALLY DISCLAIMS ANY AND ALL IMPLIED WARRANTIES, INCLUDING, WITHOUT LIMITATION, WARRANTIES OF MERCHANTABILITY AND FITNESS FOR A PARTICULAR PURPOSE. IF KRAMER ELECTRONICS CANNOT LAWFULLY DISCLAIM OR EXCLUDE IMPLIED WARRANTIES UNDER APPLICABLE LAW, THEN ALL IMPLIED WARRANTIES COVERING THIS PRODUCT, INCLUDING WARRANTIES OF MERCHANTABILITY AND FITNESS FOR A PARTICULAR PURPOSE, SHALL APPLY TO THIS PRODUCT AS PROVIDED UNDER APPLICABLE LAW. IF ANY PRODUCT TO WHICH THIS LIMITED WARRANTY APPLIES IS A "CONSUMER PRODUCT" UNDER THE MAGNUSON-MOSS WARRANTY ACT (15 U.S.C.A. §2301, ET SEQ.) OR OTHER APPLICABLE LAW, THE FOREGOING DISCLAIMER OF IMPLIED WARRANTIES SHALL NOT APPLY TO YOU, AND ALL IMPLIED WARRANTIES ON THIS PRODUCT, INCLUDING WARRANTIES OF MERCHANTABILITY AND FITNESS FOR THE PARTICULAR PURPOSE, SHALL APPLY AS PROVIDED UNDER APPLICABLE LAW.

### **Other Conditions**

This limited warranty gives you specific legal rights, and you may have other rights which vary from country to country or state to state.

This limited warranty is void if (i) the label bearing the serial number of this product has been removed or defaced, (ii) the product is not distributed by Kramer Electronics or (iii) this product is not purchased from an authorized Kramer Electronics reseller. If you are unsure whether a reseller is an authorized Kramer Electronics reseller, visit our web site at [www.kramerav.com](http://www.kramerav.com) or contact a Kramer Electronics office from the list at the end of this document.

Your rights under this limited warranty are not diminished if you do not complete and return the product registration form or complete and submit the online product registration form. Kramer Electronics thanks you for purchasing a Kramer Electronics product. We hope it will give you years of satisfaction.



**HDMI™**  
HIGH-DEFINITION MULTIMEDIA INTERFACE



P/N: 2900-301565

Rev: 1



#### SAFETY WARNING

Disconnect the unit from the power supply before opening and servicing

For the latest information on our products and a list of Kramer distributors, visit our website where updates to this user manual may be found.

We welcome your questions, comments, and feedback.

The terms HDMI, HDMI High-Definition Multimedia Interface, and the HDMI Logo are trademarks or registered trademarks of HDMI Licensing Administrator, Inc. All brand names, product names, and trademarks are the property of their respective owners.