



KRAMER ELECTRONICS LTD.

# USER MANUAL

MODEL:

**VS-88DT**

HDMI/HDBT Matrix Switcher

---

P/N: 2900-300275 Rev 1

# VS-88DT 8x8 HDMI/HDBT Matrix Switcher Quick Start Guide



This guide helps you install and use your product for the first time. For more detailed information, go to [http://www.kramerelectronics.com/support/product\\_downloads.asp](http://www.kramerelectronics.com/support/product_downloads.asp) to download the latest manual or scan the QR code on the left.

## Step 1: Check what's in the box

- VS-88DT 8x8 HDMI/HDBT Matrix Switcher
- 1 Power cord
- 1 Set of rack "ears"
- 1 Quick Start Guide
- Kramer RC-IR3 Infrared RC Transmitter
- 4 Rubber feet

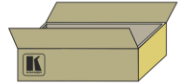

Save the original box and packaging in case your VS-88DT needs to be returned to the factory for service.

## Step 2: Install the VS-88DT

Mount the machine in a rack (using the included rack "ears") or attach the rubber feet and place it on a shelf.

## Step 3: Connect the inputs and outputs

Always switch off the power to all devices before connecting them to your VS-88DT.

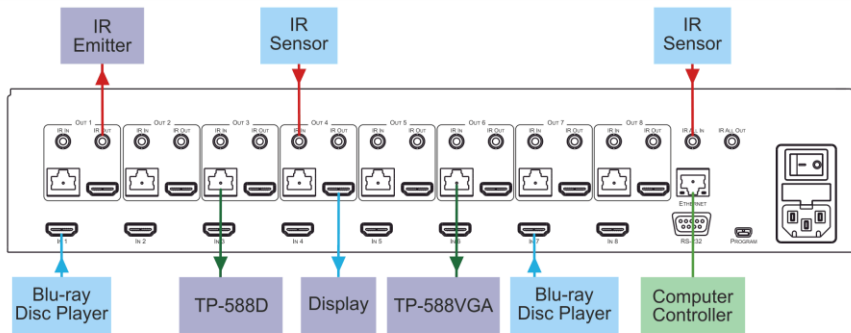

For optimum performance we recommend the Kramer **BC-HDKat6a** (CAT 6 23 AWG) cable. This specially built cable significantly outperforms regular CAT 5/CAT 6/CAT 7a cables.

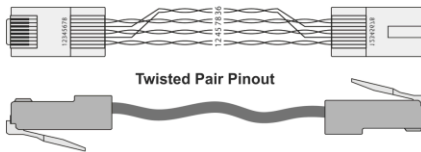

| EIA / TIA 568B |                |
|----------------|----------------|
| PIN            | Wire Color     |
| 1              | Orange / White |
| 2              | Orange         |
| 3              | Green / White  |
| 4              | Blue           |
| 5              | Blue / White   |
| 6              | Green          |
| 7              | Brown / White  |
| 8              | Brown          |

## Step 4: Connect the power

Connect the power cord to the VS-88DT and plug it into the mains electricity.



## Step 5: Operate the VS-88DT

### To switch an input to an output:

1. Press a button on the top row to select an output.
2. Press a button on the bottom row to select an input to switch to the output.

### Use the Menu to configure the device:

1. Press Menu to enter the menu.
2. Navigate the menu using the Enter and arrow buttons.
3. Press Menu to exit the Menu.

### To Copy an EDID from an output to an input:

1. Press EDID.
2. Press the required Out button.
3. Press the required In button.
4. Press EDID.

### To Copy an EDID from an output to all inputs:

1. Press EDID.
2. Press the required Out button.
3. Press the required In button.
4. Repeat steps 2 and 3 for each EDID to copy.
5. Press EDID.

# Contents

|             |   |           |
|-------------|---|-----------|
| <b>1</b>    | <b>Introduction</b>                                       | <b>1</b>  |
| <b>2</b>    | <b>Getting Started</b>                                    | <b>2</b>  |
| 2.1         | Achieving the Best Performance                            | 2         |
| 2.2         | Safety Instructions                                       | 2         |
| 2.3         | Using TP cables   | 3         |
| 2.4         | Recycling Kramer Products                                 | 3         |
| <b>3</b>    | <b>Overview</b>   | <b>4</b>  |
| 3.1         | About HDBaseT™ Technology                                 | 5         |
| <b>4</b>    | <b>Defining the VS-88DT HDMI/HDBT Matrix Switcher</b>     | <b>6</b>  |
| <b>5</b>    | <b>Installing the VS-88DT in a Rack</b>                   | <b>9</b>  |
| <b>6</b>    | <b>Connecting the VS-88DT</b>                             | <b>10</b> |
| 6.1         | Connecting a Serial Controller to the VS-88DT             | 11        |
| 6.2         | Connecting to the VS-88DT via Ethernet                    | 11        |
| <b>7</b>    | <b>Operating the VS-88DT</b>                              | <b>15</b> |
| 7.1         | Switching Inputs to Outputs                               | 15        |
| 7.2         | Storing and Recalling Preset Configurations               | 16        |
| 7.3         | Acquiring an EDID   | 17        |
| 7.4         | Cancelling One or All Outputs                             | 17        |
| 7.5         | Resetting the Device to Factory Default Configuration     | 18        |
| 7.6         | Locking and Unlocking the Front Panel                     | 19        |
| <b>8</b>    | <b>Configuring the VS-88DT</b>                            | <b>20</b> |
| 8.1         | Using the Menu  | 20        |
| 8.2         | Selecting the HDBaseT or HDMI Outputs                     | 22        |
| 8.3         | Selecting DHCP  | 22        |
| 8.4         | Configuring the IP Network Address                        | 23        |
| 8.5         | Resetting the VS-88DT to Factory Default Configuration    | 24        |
| <b>9</b>    | <b>Operating the VS-88DT Remotely Using the Web Pages</b> | <b>25</b> |
| 9.1         | Switching Page  | 25        |
| 9.2         | Device Settings Page                                      | 29        |
| 9.3         | Authentication Page                                       | 30        |
| 9.4         | RS-232 Routing Page                                       | 32        |
| 9.5         | EDID Page   | 33        |
| 9.6         | About Page  | 34        |
| <b>10</b>   | <b>Wiring the DGKat TP RJ-45 Connectors</b>               | <b>35</b> |
| <b>11</b>   | <b>Updating the Firmware</b>                              | <b>36</b> |
| <b>12</b>   | <b>Technical Specifications</b>                           | <b>38</b> |
| <b>13</b>   | <b>Default Parameters</b>                                 | <b>39</b> |
| 13.1        | Default Communication Parameters                          | 39        |
| <b>14</b>   | <b>Kramer Protocol</b>                                    | <b>40</b> |
| <b>14.1</b> | <b>Kramer Protocol 3000 Syntax</b>                        | <b>40</b> |
| 14.2        | Kramer Protocol 3000 Commands                             | 43        |

# Figures

|  |    |
|--|----|
| Figure 1: VS-88DT HDMI/HDBT Matrix Switcher Front Panel    | 6  |
| Figure 2: VS-88DT HDMI/HDBT Matrix Switcher Rear Panel     | 8  |
| Figure 3: Connecting the VS-88DT HDMI/HDBT Matrix Switcher | 10 |
| Figure 4: Local Area Connection Properties Window          | 12 |
| Figure 5: Internet Protocol Version 4 Properties Window    | 13 |
| Figure 6: Internet Protocol Properties Window              | 14 |
| Figure 7: Login Page                                       | 25 |
| Figure 8: Switching Page                                   | 26 |
| Figure 9: Switching Button Details                         | 27 |
| Figure 10: Input Properties Popup                          | 27 |
| Figure 11: Output Properties Popup                         | 28 |
| Figure 12: Device Settings Page                            | 30 |
| Figure 13: Authentication Page                             | 31 |
| Figure 14: RS-232 Routing Page                             | 32 |
| Figure 15: EDID Page                                       | 33 |
| Figure 16: About Page                                      | 34 |
| Figure 17: TP Pinout Wiring                                | 35 |

---

# 1 Introduction

Welcome to Kramer Electronics! Since 1981, Kramer Electronics has been providing a world of unique, creative, and affordable solutions to the vast range of problems that confront the video, audio, presentation, and broadcasting professional on a daily basis. In recent years, we have redesigned and upgraded most of our line, making the best even better!

Our 1,000-plus different models now appear in 11 groups that are clearly defined by function: GROUP 1: Distribution Amplifiers; GROUP 2: Switchers and Routers; GROUP 3: Control Systems; GROUP 4: Format/Standards Converters; GROUP 5: Range Extenders and Repeaters; GROUP 6: Specialty AV Products; GROUP 7: Scan Converters and Scalers; GROUP 8: Cables and Connectors; GROUP 9: Room Connectivity; GROUP 10: Accessories and Rack Adapters and GROUP 11: Sierra Products.

Congratulations on purchasing your **VS-88DT HDMI/HDBT Matrix Switcher** which is ideal for:

- Conference room presentations
- Advertising applications

---

## 2 Getting Started

We recommend that you:

- Unpack the equipment carefully and save the original box and packaging materials for possible future shipment
- Review the contents of this user manual



Go to [http://www.kramerelectronics.com/support/product\\_downloads.asp](http://www.kramerelectronics.com/support/product_downloads.asp) to check for up-to-date user manuals, application programs, and to check if firmware upgrades are available (where appropriate).

### 2.1 Achieving the Best Performance

To achieve the best performance:

- Use only good quality connection cables (we recommend Kramer high-performance, high-resolution cables) to avoid interference, deterioration in signal quality due to poor matching, and elevated noise levels (often associated with low quality cables)
- Do not secure the cables in tight bundles or roll the slack into tight coils
- Avoid interference from neighboring electrical appliances that may adversely influence signal quality
- Position your Kramer **VS-88DT** away from moisture, excessive sunlight and dust



This equipment is to be used only inside a building. It may only be connected to other equipment that is installed inside a building.

### 2.2 Safety Instructions



**Caution:** There are no operator serviceable parts inside the unit

**Warning:** Use only the power cord that is supplied with the unit

**Warning:** Do not open the unit. High voltages can cause electrical shock! Servicing by qualified personnel only

**Warning:** Disconnect the power and unplug the unit from the wall before installing

## 2.3 Using TP cables

Kramer engineers have developed a special twisted pair cable to best match our HDBaseT products, the Kramer **BC-HDKat6a** (CAT 6 23 AWG) cable. This specially built cable significantly outperforms regular CAT 5/CAT 6/CAT 7a cables.

## 2.4 Recycling Kramer Products

The Waste Electrical and Electronic Equipment (WEEE) Directive 2002/96/EC aims to reduce the amount of WEEE sent for disposal to landfill or incineration by requiring it to be collected and recycled. To comply with the WEEE Directive, Kramer Electronics has made arrangements with the European Advanced Recycling Network (EARN) and will cover any costs of treatment, recycling and recovery of waste Kramer Electronics branded equipment on arrival at the EARN facility. For details of Kramer's recycling arrangements in your particular country go to our recycling pages at <http://www.kramerelectronics.com/support/recycling/>.

---

## 3 Overview

The high-quality Kramer **VS-88DT** is an *HDMI/HDBT Matrix Switcher* that accepts up to eight HDMI signals and routes any or all of them to any or all eight HDMI outputs or HDBaseT for connection to compatible receivers, for example, the **TP-588D** and **TP-588VGA**.

The **VS-88DT** features:

- Eight HDMI and nine IR inputs
- Eight HDMI, eight HDBaseT and nine IR outputs
- Bandwidth up to 6.75Gbps (2.25Gbps per video channel)
- EDID Capture—copies and stores the EDID from a display device
- Hot-plug Detect (HPD)
- HDBaseT range up to 100m (328ft)
- HDCP support
- HDTV compatibility
- Support for HDMI – 3D, Deep Color, x.v.Color™, Lip Sync, Dolby® TrueHD, Dolby Digital Plus, DTS-HD® and linear PCM 7.1 surround sound
- A non-volatile memory for matrix configuration
- A store and recall facility for preset configurations
- Automatic output shutdown if no input signal is detected after a configurable idle period
- An LCD display for easy configuration and operation
- Remote control using serial commands (over RS-232 and Ethernet) and built-in, browser-based Web pages
- Support for Kramer Protocol 3000
- A lock button to prevent unwanted tampering with the settings
- 2U height that fits a standard 19" professional rack enclosure



You can control the **VS-88DT** using the front panel buttons, or remotely via:

- Built-in, embedded Web pages using a standard Web browser over Ethernet
- RS-232 serial commands transmitted by a touch screen system, PC or other serial controller
- The Kramer infrared remote control transmitter

### 3.1 About HDBaseT™ Technology

HDBaseT™ is an advanced all-in-one connectivity technology (supported by the HDBaseT Alliance). It is particularly suitable in the consumer home environment as a digital home networking alternative where it enables you to replace numerous cables and connectors by a single LAN cable used to transmit, for example, uncompressed, full, high definition video, audio and IR as well as various control signals.

## 4 Defining the VS-88DT HDMI/HDBT Matrix Switcher

Figure 1 defines the front panel of the VS-88DT.

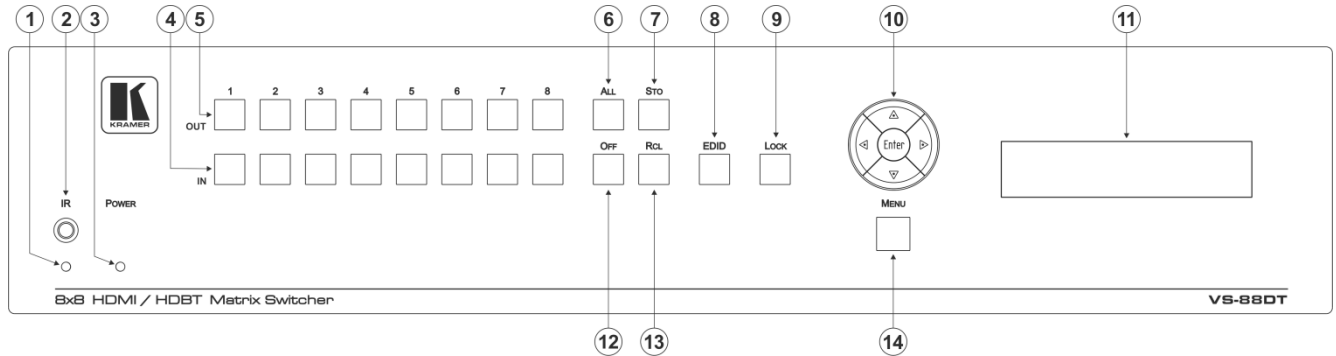

Figure 1: VS-88DT HDMI/HDBT Matrix Switcher Front Panel

| # | Feature     | Function  |
|---|-------------|---|
| 1 | IR LED      | Lights yellow when receiving an IR signal   |
| 2 | IR Sensor   | IR receiver for remote control  |
| 3 | POWER LED   | Lights green when the device is powered on  |
| 4 | IN 1~8      | Press to select an input after selecting an output (see <a href="#">Section 7.1</a> )   |
| 5 | OUT 1~8     | Press to switch, followed by an input or OFF  |
| 6 | ALL Button  | Press, followed by an Input to switch the Input to all outputs or press followed by the Off button to disconnect all switches, (see <a href="#">Section 7.4</a> ) |
| 7 | STO Button  | Press to store a preset configuration followed by the preset number in which to save it (see <a href="#">Section 7.2</a> )  |
| 8 | EDID Button | Press to copy the EDID from an Output to an Input (see <a href="#">Section 7.3</a> )  |

| #  | Feature                            | Function  |
|----|------------------------------------|---|
| 9  | <i>LOCK</i> Button                 | Press and hold to lock the front panel buttons, (see <a href="#">Section 7.6</a> ). Press and hold again to unlock  |
| 10 | Menu Navigation Pad                | Use the Enter, up (▲), down (▼), left (◀) and right (▶) buttons to navigate the menu, and modify parameters or values (see <a href="#">Section 8.1</a> )                      |
| 11 | LCD Readout<br>(20 char x 2 lines) | Displays either the input/output resolution currently selected or the menu during configuration   |
| 12 | <i>OFF</i> Button                  | Press after an output button to cancel the currently selected outputs. Press after the All button to cancel all currently switched outputs (see <a href="#">Section 7.4</a> ) |
| 13 | <i>RCL</i> Button                  | Press, followed by a preset number to recall the preset configuration (see <a href="#">Section 7.2</a> )  |
| 14 | <i>MENU</i> Button                 | Press to enter the Menu and move one level back when the menu is displayed (see <a href="#">Section 8.1</a> )   |

Figure 2 defines the rear panel of the VS-88DT.

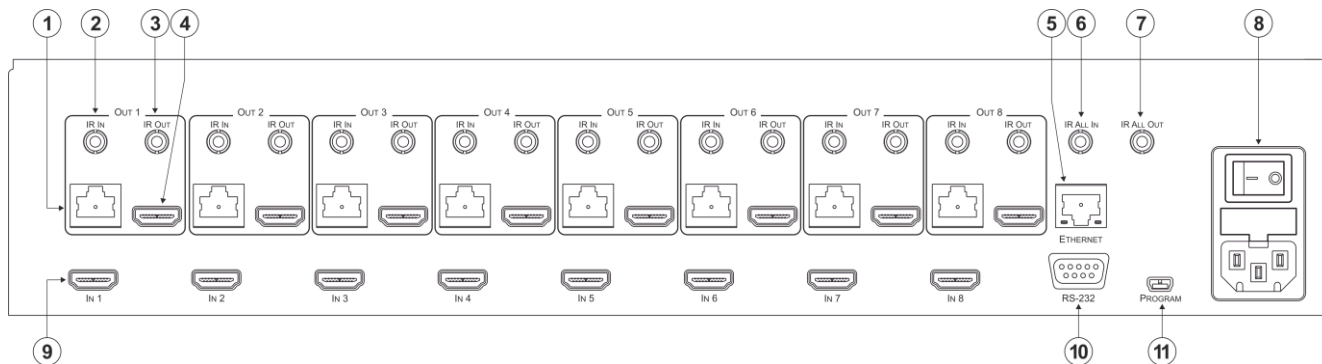

Figure 2: VS-88DT HDMI/HDBT Matrix Switcher Rear Panel

| #  | Feature                        | Function   |
|----|--------------------------------|--|
| 1  | RJ-45 HDBaseT Connector        | Connect to compatible HDBaseT devices, for example, TP-588D (see <a href="#">Section 6</a> ) |
| 2  | OUT 1-8                        | IR IN 3.5mm Mini Jack  |
| 3  |                                | IR OUT 3.5mm Mini Jack   |
| 4  |                                | HDMI Connector   |
| 5  | ETHERNET RJ-45 Connector       | Connect to a PC controller via a LAN (see <a href="#">Section 6.2</a> )                      |
| 6  | IR ALL IN 3.5mm Mini Jack      | Connect to an IR sensor  |
| 7  | IR ALL OUT 3.5mm Mini Jack     | Connect to an IR blaster   |
| 8  | AC Mains                       | Power Socket   |
|    |                                | Fuse   |
|    |                                | Power Switch   |
| 9  | IN 1-8 HDMI Connectors         | Connect to HDMI sources  |
| 10 | RS-232 9-pin D-sub Serial Port | Connect to a serial controller (see <a href="#">Section 6.1</a> )                            |
| 11 | PROGRAM Mini USB Connector     | For performing firmware upgrade  |

## 5 Installing the VS-88DT in a Rack

**Before installing in a rack**, be sure that the environment is within the recommended range:

|                        |                               |
|------------------------|-------------------------------|
| OPERATING TEMPERATURE: | 0° to +40°C (32° to 104°F)    |
| STORAGE TEMPERATURE:   | -40° to +70°C (-40° to 158°F) |
| HUMIDITY:              | 10% to 90% RHL non-condensing |



### CAUTION!

When installing on a 19" rack, avoid hazards by taking care that:

1. It is located within the recommended environmental conditions, as the operating ambient temperature of a closed or multi unit rack assembly may exceed the room ambient temperature.
2. Once rack mounted, enough air will still flow around the machine.
3. The machine is placed straight in the correct horizontal position.
4. You do not overload the circuit(s). When connecting the machine to the supply circuit, overloading the circuits might have a detrimental effect on overcurrent protection and supply wiring. Refer to the appropriate nameplate ratings for information. For example, for fuse replacement, see the value printed on the product label.
5. The machine is earthed (grounded) in a reliable way and is connected only to an electricity socket with grounding. Pay particular attention to situations where electricity is supplied indirectly (when the power cord is not plugged directly into the socket in the wall), for example, when using an extension cable or a power strip, and that you use only the power cord that is supplied with the machine.

### To rack-mount a machine:

1. Attach both ear brackets to the machine. To do so, remove the screws from each side of the machine (5 on each side), and replace those screws through the ear brackets.

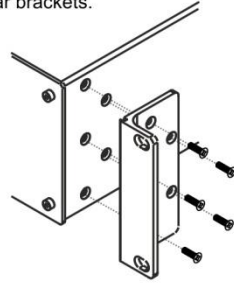

2. Place the ears of the machine against the rack rails, and insert the proper screws (not provided) through each of the four holes in the rack ears.

#### Note:

- In some models, the front panel may feature built-in rack ears
- Detachable rack ears can be removed for desktop use
- Always mount the machine in the rack before you attach any cables or connect the machine to the power
- If you are using a Kramer rack adapter kit (for a machine that is not 19"), see the Rack Adapters user manual for installation instructions available from our Web site

## 6 Connecting the VS-88DT



Switch off the power to all devices before connecting them to your **VS-88DT**. After connecting your **VS-88DT**, connect its power and then switch on the power to the other devices.

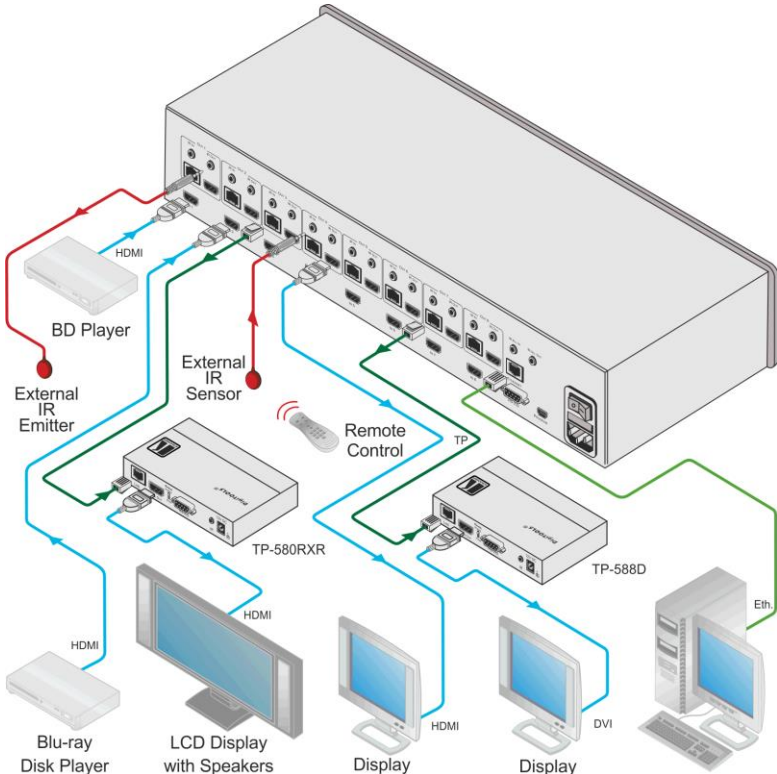

Figure 3: Connecting the VS-88DT HDMI/HDBT Matrix Switcher

To connect the VS-88DT as illustrated in the example in [Figure 3](#):

1. Connect the HDMI sources, (for example, Blu-ray disc players) to the HDMI In 1 and In 2 connectors.
2. Connect an external IR sensor to the In 4 IR In 3.5mm mini jack.
3. Connect the Out 1 IR 3.5mm mini jack to an external IR transmitter.

4. Connect the Out 4 HDMI connector to an HDMI acceptor, (for example, a display).
5. Connect the Out 3 TP RJ-45 HDBT connector to a compatible HDBT receiver, (for example, the **TP-580Rxr**), and connect the HDMI output of the **TP-580Rxr** to a display.
6. Connect the Out 7 TP RJ-45 HDBT connector to a compatible HDBT receiver, (for example, the **TP-588D**), and connect the DVI output of the **TP-588D** to a display.
7. Connect a controller via either RS-232 or a LAN to the Ethernet RJ-45 connector.

## 6.1 Connecting a Serial Controller to the VS-88DT

You can connect to the **VS-88DT** via an RS-232 connection using, for example, a PC.

### To connect to the VS-88DT via RS-232:

- Connect the 9-pin D-sub connector on the rear panel of the **VS-88DT** (pin 5 to pin 5, pin 2 to pin 3, pin 3 to pin 2) to the RS 232 9-pin D-sub port on your PC

## 6.2 Connecting to the VS-88DT via Ethernet

You can connect to the **VS-88DT** via Ethernet using either of the following methods:

- Directly to the PC using a crossover cable (see [Section 6.2.1](#))
- Via a network hub, switch, or router, using a straight-through cable (see [Section 6.2.2](#))

**Note:** If you want to connect via a router and your IT system is based on IPv6, speak to your IT department for specific installation instructions.

## 6.2.1 Connecting the Ethernet Port Directly to a PC

You can connect the Ethernet port of the **VS-88DT** directly to the Ethernet port on your PC using a crossover cable with RJ-45 connectors.



This type of connection is recommended for identifying the **VS-88DT** with the factory configured default IP address.

After connecting the **VS-88DT** to the Ethernet port, configure your PC as follows:

1. Click **Start > Control Panel > Network and Sharing Center**.
2. Click **Change Adapter Settings**.
3. Highlight the network adapter you want to use to connect to the device and click **Change settings of this connection**.

The Local Area Connection Properties window for the selected network adapter appears as shown in [Figure 4](#).

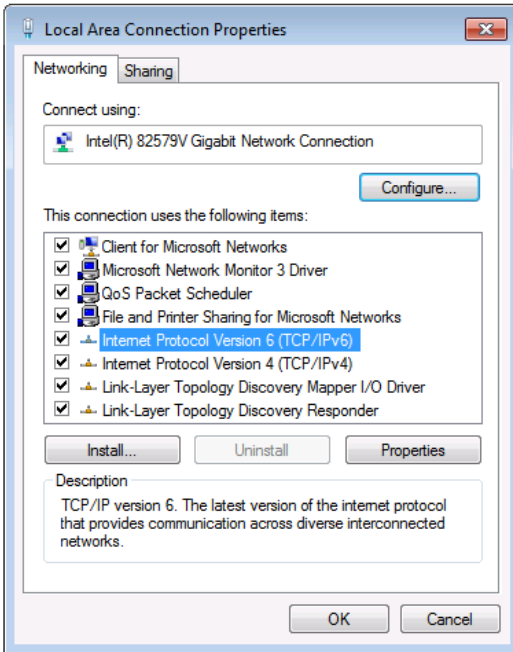

Figure 4: Local Area Connection Properties Window



4. Highlight **Internet Protocol Version 4 (TCP/IPv4)**.
5. Click **Properties**.

The Internet Protocol Properties window appears as shown in [Figure 5](#).

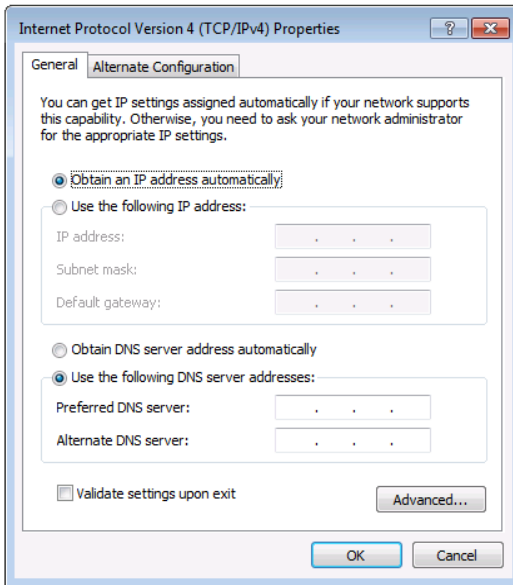

Figure 5: Internet Protocol Version 4 Properties Window

6. Select **Use the following IP Address** for static IP addressing and fill in the details as shown in [Figure 6](#).

For TCP/IPv4 you can use any IP address in the range 192.168.1.1 to 192.168.1.255 (excluding 192.168.1.39) that is provided by your IT department.

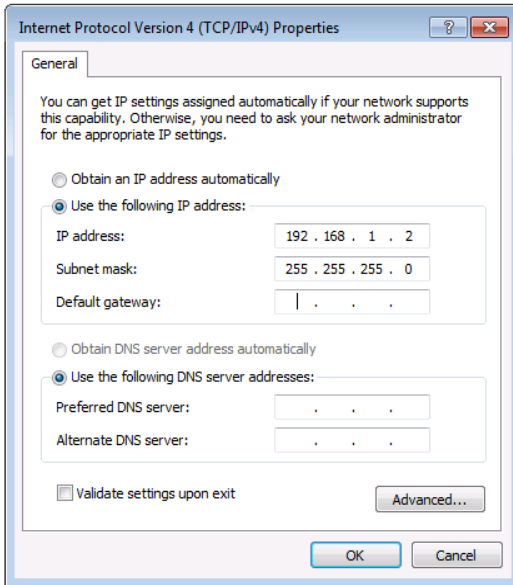

Figure 6: Internet Protocol Properties Window

7. Click **OK**.
8. Click **Close**.

## 6.2.2 Connecting the Ethernet Port via a Network Hub or Switch

You can connect the Ethernet port of the **VS-88DT** to the Ethernet port on a network hub or using a straight-through cable with RJ-45 connectors.

---

## 7 Operating the VS-88DT

When the **VS-88DT** is powered on, the following is displayed briefly on the LCD display:

KRAMER ELEC

8X8 HDMI/HDBT Matrix

Following the self-test the current switching configuration is displayed, an example of which is shown below. The top row indicates the output port and the bottom row indicates which input port is switched to the output port displayed directly above it. An input port showing 0 (zero) indicates that the output port has no input switched to it.

```
O:  1  2  3  4  5  6  7  8
I:  3  0  1  2  4  5  2  8
```

**Note:** If there is no button activity during any procedure for approximately 30 seconds, the procedure is aborted and the display reverts back to the Input/Output display.

### 7.1 Switching Inputs to Outputs

You can switch:

- Individual inputs to individual outputs
- One input to all outputs

**To switch an output to an input, (for example, Input 7 to Output 3):**

1. Press Out 3.  
The Output button lights red.
2. Press In 7.  
The Input button lights red and the switch is performed.

**To switch one input to all outputs, (for example, Input 2 to all outputs):**

1. Press All.  
The All button lights red.
2. Press In 2.  
The Input 2 button lights and Input 2 is switched to all outputs.

## **7.2 Storing and Recalling Preset Configurations**

You can store up to eight preset configurations for instant recall. The top row of output buttons relate to presets one to eight.

**To store the current configuration in preset 5:**

1. Press Sto.
2. Press Out 5.  
The selection is displayed in the readout.
3. Press Sto.  
The current configuration is stored in preset 5.

**To recall preset 8:**

1. Press Rcl.
2. Press Out 8.  
The selection is displayed in the readout.
3. Press Rcl.  
The configuration stored in preset 8 is recalled.

## 7.3 Acquiring an EDID

You can acquire the EDID from an output and assign it to either one or all inputs.

**To acquire the EDID from an output and store it on one input, (for example, Output 5 to Input 8):**

1. Press EDID.  
The button lights red.
2. Press Out 5.
3. Press In 8.
4. Press EDID.  
The button no longer lights and the EDID from Output 5 is stored in Input 8.

## 7.4 Cancelling One or All Outputs

The Off button is used to cancel one or all currently switched outputs.

**To cancel one currently switched output, (for example, Output 7):**

1. Press Out 7.
2. Press Off.

**To cancel all currently switched outputs:**

1. Press All.
2. Press Off.

## 7.5 Resetting the Device to Factory Default Configuration

The **VS-88DT** can be reset to factory default configuration either by sending a Protocol 3000 command or by using the front panel buttons.

**To reset the device to the factory default configuration by sending a P3000 command:**

1. Connect from a PC to the **VS-88DT** via the serial port using the following parameters:
  - 115200, 8, 1, none
2. Send the P3000 command to reset the device to factory default (see [Section 14.2](#)).

After a few seconds the **VS-88DT** is reset to factory default.

**To reset the device to the factory default configuration using the front panel buttons:**

1. Press the Menu button.  
The Menu button lights and the first option on the menu appears.
2. Use the up (▲) and down (▼) arrows on the keypad to scroll to the RESET TO DEFAULT option.
3. Press the Enter button.  
The Reset to Default No and Yes options appear.
4. Use the left (◀) and right (▶) arrows on the keypad to select Yes.
5. Press Enter.  
After a few seconds the standby readout is displayed and the device is reset to factory default.

## 7.6 Locking and Unlocking the Front Panel

You can lock the front panel buttons to prevent unwanted key presses from changing the current configuration.

### **To lock the front panel:**

- Press and hold the Lock button.  
The button lights, the Locked message is displayed briefly, and the front panel buttons are locked. Pressing any button causes the Locked message to display briefly and the Lock button to flash

### **To unlock the front panel:**

- Press and hold the Lock button.  
The button no longer lights and the front panel buttons are unlocked

---

## 8 Configuring the VS-88DT

### 8.1 Using the Menu

The main menu comprises three sections:

- Interface Out (see [Section 8.1.1](#))
- RS-232 Routing (see [Section 8.1.2](#))
- DHCP (see [Section 8.1.3](#))
- Ethernet Status (see [Section 8.1.4](#))
- FW version display (see [Section 8.1.5](#))
- Reset to Default (see [Section 8.1.6](#))
- Update Firmware (see [Section 8.1.7](#))

Navigation through the menu is performed as follows:

- Menu—Enter the Menu or exit one level when in the Menu
- Enter—Select a parameter/value
- Up (▲) or Right (▶)—scroll up through the parameter/value list
- Down (▼) or Left (◀)—scroll down through the parameter/value list

**Note:** If there is no button activity for approximately 30 seconds, the display reverts back to the Input/Output display.

#### 8.1.1 Interface Out Sub-menu

The parameters in the Interface Out sub-menu set the output signal format.

| Parameter   | Description               | Options                    |
|-------------|---------------------------|----------------------------|
| Output 1~8: | Sets the required outputs | HDBT, HDMI<br>Default—HDBT |



### 8.1.2 RS-232 Routing Sub-menu

The RS-232 Status sub-menu turns the RS-232 serial communication routing on and off.

| Parameter | Description                         | Options                |
|-----------|-------------------------------------|------------------------|
| OFF, ON   | Turns the RS-232 routing on and off | OFF, ON<br>Default—OFF |

### 8.1.3 Network Settings Sub-menu

The Network Status sub-menu controls DHCP selection and IP network parameters.

| Parameter        | Description                 | Options                        |
|------------------|-----------------------------|--------------------------------|
| OFF, ON          | Turns DHCP on and off       | OFF, ON<br>Default—OFF         |
| IP Settings      | Sets the IP network address | All valid IP addresses         |
| Netmask Settings | Sets the IP netmask         | All valid IP netmask addresses |
| Gateway Settings | Sets the IP gateway         | All valid IP gateway addresses |

**Note:** When turning DHCP on, the device performs an automatic reset.

### 8.1.4 Ethernet Status Sub-menu

The parameters in the Ethernet Status sub-menu display the TCP/IP communication parameters.

| Parameter       | Description                               |
|-----------------|---|
| IP Status:      | Displays the TCP/IP address of the device |
| Netmask Status: | Displays the TCP/IP netmask of the device |
| Gateway Status: | Displays the TCP/IP gateway               |
| MAC Address:    | Displays the MAC address of the device    |

### 8.1.5 FW Version Display

Displays the firmware version similar to the following:

V1.1.1123+04A+1.0

### 8.1.6 Reset to Default Sub-menu

| Parameter | Description                                     |
|-----------|---|
| NO, YES   | Resets the device to default factory parameters |

### 8.1.7 Update Firmware Sub-menu

| Parameter      | Description              |
|----------------|--------------------------|
| Update I/O FW: | Updates the I/O firmware |

## 8.2 Selecting the HDBaseT or HDMI Outputs

**To select the HDBaseT or HDMI outputs:**

1. Press the Menu button to display the menu.  
The menu is displayed.
2. Using the up (▲) or down (▼) button, move through the menu options until the Interface Out: option is displayed.
3. Press Enter.  
The HDBaseT and HDMI options are displayed.
4. Using the left (◀) or right (▶) button, select either HDBaseT or HDMI.
5. Press Enter.  
The change is saved.

## 8.3 Selecting DHCP

**Note:** Turning DHCP off does not de-encrypt encoded streams, it simply indicates to the source that DHCP is not supported.

**To select the DHCP:**

1. Press the Menu button to display the menu.  
The menu is displayed.
2. Using the up (▲) or down (▼) button, move through the menu options until the Network Settings option is displayed.

3. Press Enter.  
The DHCP On and OFF options are displayed.
4. Using the left (◀) or right (▶) button, select either On or Off.
5. Press Enter.  
The change is saved.

## 8.4 Configuring the IP Network Address

**To configure the IP network address:**

1. Press the Menu button to display the menu.  
The menu is displayed.
2. Using the up (▲) or down (▼) button, move through the menu options until the Network Settings option is displayed.
3. Press Enter.  
The DHCP Settings option is displayed.
4. Using the up (▲) or down (▼) button, move through the menu options until the IP Settings option is displayed.
5. Press Enter.
6. Using the left (◀) or right (▶) button, move the cursor to the digit you wish to change.
7. Using the up (▲) or down (▼) button, select the required digit.
8. Repeat steps 6 and 7 until the required address is displayed.
9. Press Enter.  
The change is saved.

## 8.5 Resetting the VS-88DT to Factory Default Configuration

**To reset the VS-88DT to factory default parameters:**

1. Press the Menu button to display the menu.  
The menu is displayed.
2. Using the up (▲) or down (▼) button, move through the menu options until the Reset to Default: option is displayed.
3. Press Enter.  
The NO and YES options are displayed.
4. Using the left (◀) or right (▶) button, select YES.
5. Press Enter.  
The device is reset to factory default parameters and automatically reboots.

## 9 Operating the VS-88DT Remotely Using the Web Pages

You can configure and control the **VS-88DT** using the embedded Web pages by connecting via a Web browser over Ethernet. For a first time connection or if you have authentication enabled the Login page shown in [Figure 7](#) is displayed.

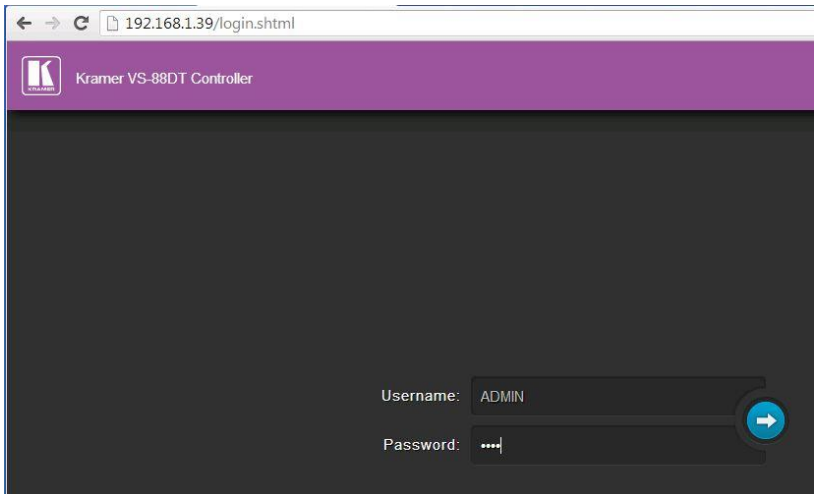

Figure 7: Login Page

If authentication is not enabled, click on the arrow. If authentication is enabled, enter a valid user name and password and click on the arrow. The Switching page shown in [Figure 8](#) is displayed.

### 9.1 Switching Page

The Switching page allows you to:

- Switch inputs to outputs
- Edit the button name
- Select either the HDMI or HDBT output
- Mute the output

- See what signal is present on the input and output
- See which input is switched to which output

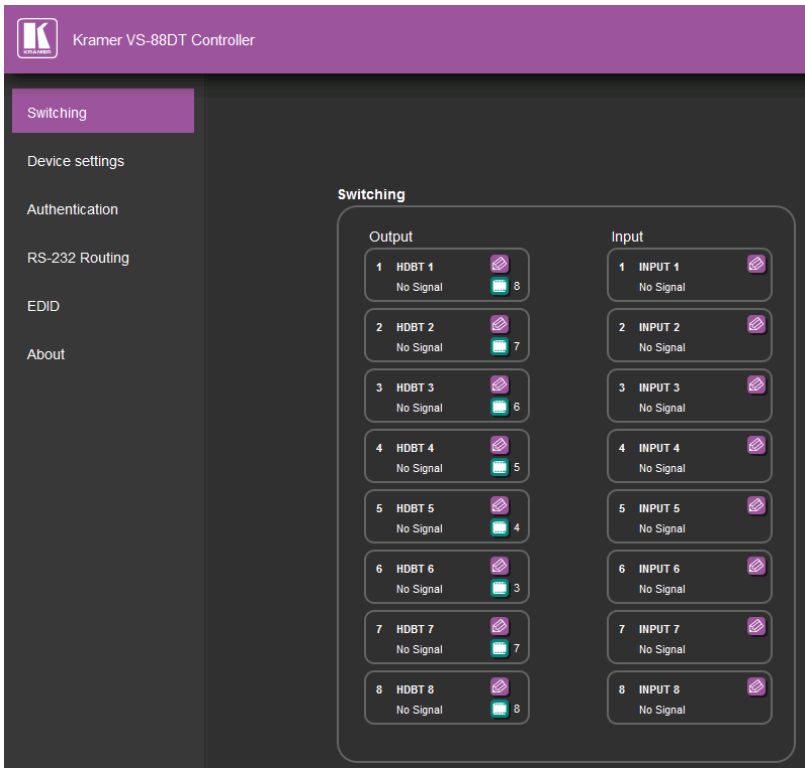

Figure 8: Switching Page

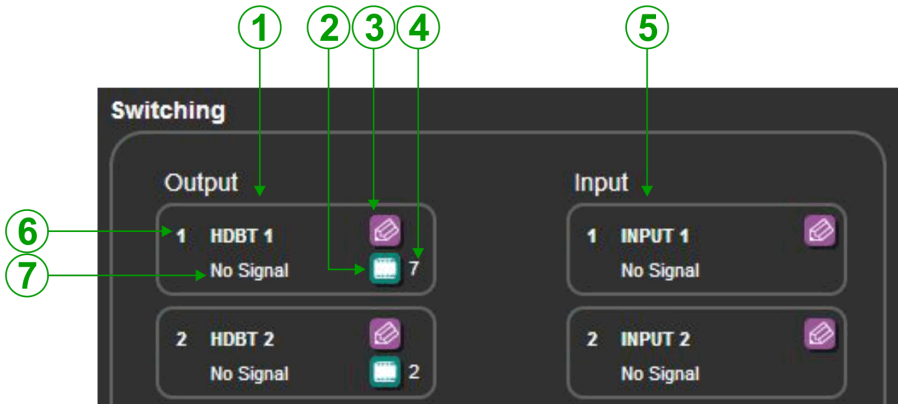

Figure 9: Switching Button Details

| # | Item                 | Description                                      |
|---|----------------------|--|
| 1 | Eight output buttons | Click on the button to select an output          |
| 2 | Mute button          | Click to mute the output                         |
| 3 | Edit button          | Click to open the button edit popup              |
| 4 | Input number         | Indicates which input is switched to this output |
| 5 | Eight input buttons  | Click to select an input                         |
| 6 | Output number        | Indicates the output number                      |
| 7 | Signal type          | Indicates the signal type present on the output  |

[Figure 11](#) shows the Input button properties popup.

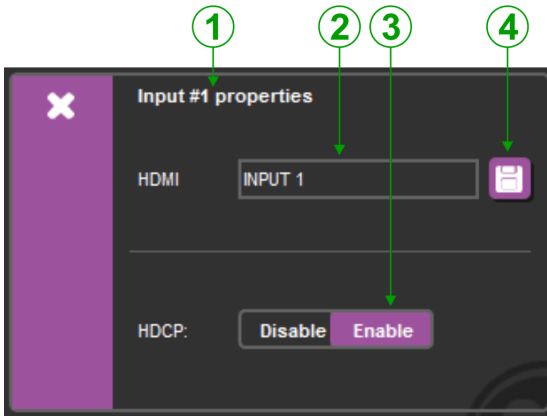

Figure 10: Input Properties Popup

| # | Item                | Description                                      |
|---|---------------------|--|
| 1 | Input #1 properties | Displays the input you are currently editing     |
| 2 | HDMI output label   | Enter the text required for the HDMI input label |
| 3 | HDCP button         | Click to enable/disable HDCP                     |
| 4 | Save button         | Click to save changes to either of the labels    |

Figure 11 shows the Output properties popup.

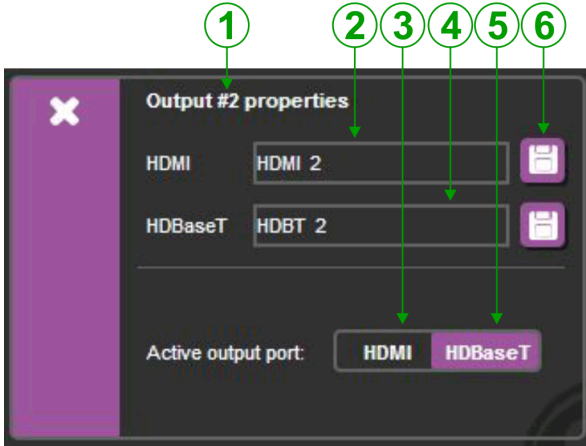

Figure 11: Output Properties Popup

| # | Item                 | Description                                       |
|---|----------------------|---|
| 1 | Output #2 properties | Displays the output you are currently editing     |
| 2 | HDMI output label    | Enter the text required for the HDMI output label |
| 3 | HDMI button          | Click to enable the HDMI output                   |
| 4 | HDBaseT output label | The current HDBaseT output label                  |
| 5 | HDBaseT button       | Click to enable the HDBaseT output                |
| 6 | Save button          | Click to save changes to either of the labels     |



### 9.1.1 Updating the Firmware

**To update the firmware:**

1. Download the latest firmware file from <http://www.kramerelectronics.com>
2. Click the Upload button.  
The file browser window appears.
3. Browse to the firmware file.
4. Select the required file and click OK.  
The new firmware is installed.

**Note:** Do not interrupt the procedure or the device may be rendered inoperable.

5. Wait until the device reboots automatically at the end of the procedure.

## 9.2 Device Settings Page

The Device Settings page allows you to:

- See the current IP settings
- Turn DHCP on and off
- Edit the IP settings for static IP

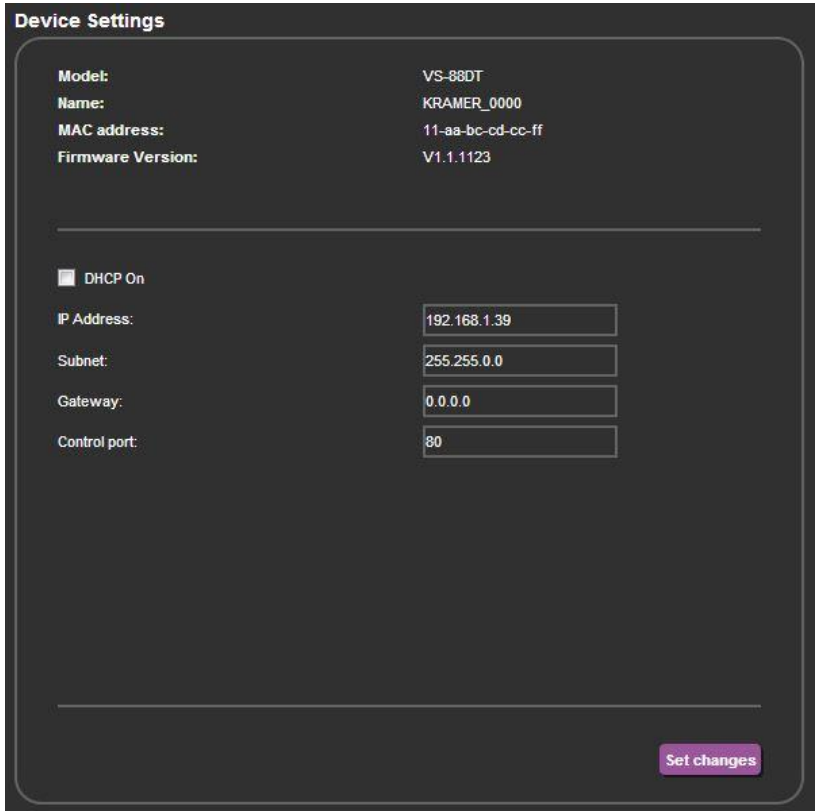

Figure 12: Device Settings Page

## 9.3 Authentication Page

There are three levels of authentication:

- No username or password required to access any settings
- Access to all settings limited to entry with a valid username and password
- Access to only the serial port settings limited to entry with a valid username and password

The Authentication page allows you to:

- Turn Web page authentication on and off

- Set the Web page access username and password
- Set the Web page access logout timeout
- Turn serial port settings access on and off
- Set the serial port settings access username and password
- Set the serial port Web page logout timeout

**Authentication**

**Authenticate Web Pages access**

Username:

Password:

Logout after  minutes of inactivity

**Authenticate Serial Control access**

Username:

Password:

Logout after  minutes of inactivity

[Set changes](#)

Figure 13: Authentication Page

## 9.4 RS-232 Routing Page

The RS-232 Routing page allows you to:

- Turn remote RS-232 routing on and off
- Select the HDBaseT output to which to route the RS-232 data
- Select the serial baud rate for each HDBaseT port

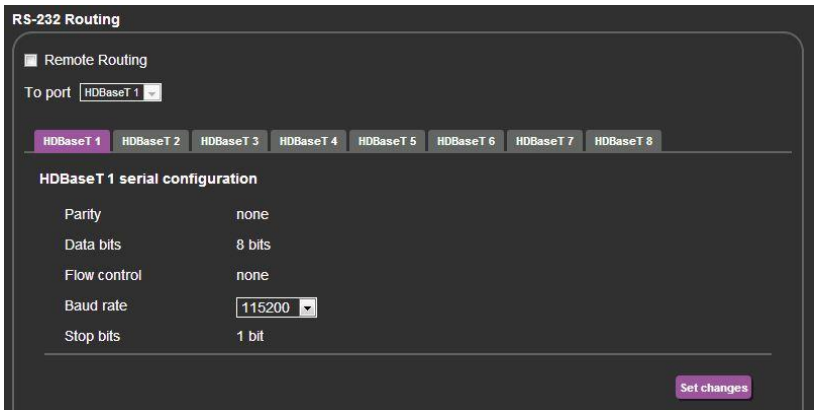

Figure 14: RS-232 Routing Page

## 9.5 EDID Page

The EDID page allows you to:

- Copy an EDID from:
  - The default EDID
  - Any HDBaseT output
  - Any input
  - An EDID stored in a file
- Copy an EDID to one or more inputs

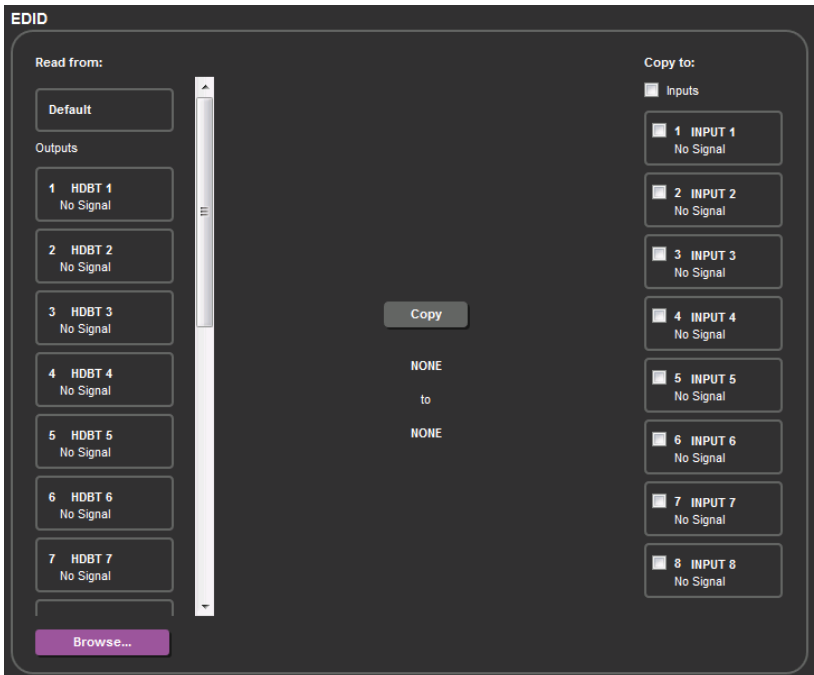

Figure 15: EDID Page

## 9.6 About Page

The About page displays the device firmware revision and the Kramer company details.



Figure 16: About Page

# 10 Wiring the DGKat TP RJ-45 Connectors

Connect/solder the cable shield to the RJ-45 connector shield.



**Do not use a crossed TP cable with this product.**

Using a TP cable that is incorrectly wired may cause permanent damage to the device

**Do not** use unshielded TP cables with this product

[Figure 17](#) the TP pinout using a straight pin-to-pin cable with RJ-45 connectors.

| EIA /TIA 568B |                |
|---------------|----------------|
| PIN           | Wire Color     |
| 1             | Orange / White |
| 2             | Orange         |
| 3             | Green / White  |
| 4             | Blue           |
| 5             | Blue / White   |
| 6             | Green          |
| 7             | Brown / White  |
| 8             | Brown          |
| Pair 1        | 4 and 5        |
| Pair 2        | 1 and 2        |
| Pair 3        | 3 and 6        |
| Pair 4        | 7 and 8        |

Figure 17: TP Pinout Wiring

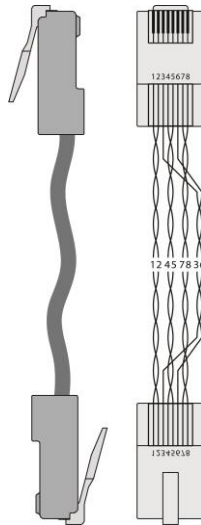

---

# 11 Updating the Firmware

The **VS-88DT** uses two microcontrollers that run firmware located in flash memory. The firmware for these microcontrollers may be upgraded independently.

## To upgrade the main microcontroller firmware:

1. From <http://www.kramerelectronics.com> download the latest firmware file to your PC, (for example, *VS-88DT\_V1.1.1111\_030713.bin*).
2. Open Windows Explorer on your PC.
3. Power off the **VS-88DT**.
4. Connect the **VS-88DT** to your PC using a USB cable.
5. Power on the **VS-88DT** while holding down the OFF button.
6. After a few seconds a removable drive is displayed in your Windows Explorer. Release the OFF button.
7. Copy the firmware file from your PC to the new removable drive.
8. After the file has been transferred, power-cycle the **VS-88DT**.  
As soon as the **VS-88DT** is ready for operation, the upgrade process is complete.

## To upgrade the I/O microcontroller firmware:

1. Download the latest firmware file, (for example, *VS-88DT\_IO(v02)\_030713.bin*) from <http://www.kramerelectronics.com> to your PC.
2. Open Windows Explorer on your PC.
3. Power off the **VS-88DT**.
4. Connect the **VS-88DT** to your PC using a USB cable.



5. Power on the **VS-88DT** while holding down the STO, RCL and LOCK buttons.
6. Copy the firmware file from your PC to the new removable drive.
7. After the file has been transferred, power-cycle the **VS-88DT**.  
As soon as the **VS-88DT** is ready for operation, the upgrade process is complete.

---

## 12 Technical Specifications

|                        |  |
|------------------------|--|
| INPUTS:                | 8 HDMI on HDMI connectors<br>9 IR on 3.5mm mini jack connectors  |
| OUTPUTS:               | 8 HDMI on HDMI connectors<br>8 HDBaseT on RJ-45 connectors<br>9 IR on 3.5mm mini jack connectors             |
| PORTS:                 | 1 Ethernet on an RJ-45 connector<br>1 Program on a mini USB connector<br>1 RS-232 on a 9-pin D-sub connector |
| VIDEO BANDWIDTH:       | 6.75Gbps (2.25Gbps per graphic channel)  |
| SUPPORTED RESOLUTIONS: | VGA to UXGA<br>480i to 1080p   |
| HDMI RANGE:            | 15m (49ft) @ 8bit resolution<br>10m (33ft) @ 12 bit resolution   |
| HDBaseT RANGE:         | 100m (328ft) 1080p @60Hz @24bpp  |
| POWER CONSUMPTION:     | 100-240V AC 50/60Hz 60VA   |
| OPERATING TEMPERATURE: | 0° to +40°C (32° to 104°F)   |
| STORAGE TEMPERATURE:   | -40° to +70°C (-40° to 158°F)  |
| HUMIDITY:              | 10% to 90%, RHL non-condensing   |
| DIMENSIONS:            | 19" x 13.94" x 2U (W, D, H) rack mountable   |
| WEIGHT:                | 3.2kg (7.05lbs) approx.  |
| INCLUDED ACCESSORIES:  | Rack "ears" , IR blaster, IR receiver  |

---

## 13 Default Parameters

### 13.1 Default Communication Parameters

| RS-232                        |              |
|-------------------------------|--------------|
| Baud Rate                     | 115,200      |
| Data Bits                     | 8            |
| Stop Bits                     | 1            |
| Parity                        | None         |
| Command Format                | ASCII        |
| Example (Output 1 to Input 1) | #AV 1>1<CR>  |
| Ethernet                      |              |
| IP Address                    | 192.168.1.39 |
| Subnet mask                   | 255.255.0.0  |
| Default gateway               | 192.168.1.1  |
| TCP Port #                    | 5000         |
| UDP Port #                    | 50000        |
| Maximum UDP Ports             | 10           |
| Maximum TCP Ports             | 4            |

# 14 Kramer Protocol

The **VS-88DT** supports the Kramer Protocol 3000.

The Protocol 3000 RS-232 communication protocol lets you control the machine from any standard terminal software (for example, Windows® HyperTerminal Application).

## 14.1 Kramer Protocol 3000 Syntax

### 14.1.1 Host Message Format

| Start | Address (optional)     | Body           | Delimiter |
|-------|------------------------|----------------|-----------|
| #     | <i>Destination_id@</i> | <b>Message</b> | <b>CR</b> |

#### 14.1.1.1 Simple Command

Command string with only one command without addressing:

| Start | Body  | Delimiter |
|-------|---|-----------|
| #     | <b>Command</b> <b>SP</b> <i>Parameter_1,Parameter_2,...</i> | <b>CR</b> |

#### 14.1.1.2 Command String

Formal syntax with commands concatenation and addressing:

| Start | Address                | Body   | Delimiter |
|-------|------------------------|--|-----------|
| #     | <i>Destination_id@</i> | <b>Command_1</b> <i>Parameter1_1,Parameter1_2,...</i><br><b>Command_2</b> <i>Parameter2_1,Parameter2_2,...</i><br><b>Command_3</b><br><i>Parameter3_1,Parameter3_2,...</i> ... | <b>CR</b> |

### 14.1.2 Device Message Format

| Start | Address (optional) | Body           | delimiter           |
|-------|--------------------|----------------|---------------------|
| ~     | <i>Sender_id@</i>  | <b>Message</b> | <b>CR</b> <b>LF</b> |

#### 14.1.2.1 Device Long Response

Echoing command:

| Start | Address (optional) | Body   | Delimiter           |
|-------|--------------------|--|---------------------|
| ~     | <i>Sender_id@</i>  | <b>Command</b> <b>SP</b> [ <i>Param1 ,Param2 ...</i> ] <b>result</b> | <b>CR</b> <b>LF</b> |

**CR** = Carriage return (ASCII 13 = 0x0D)

**LF** = Line feed (ASCII 10 = 0x0A)

**SP** = Space (ASCII 32 = 0x20)

### 14.1.3 Command Terms

#### Command

A sequence of ASCII letters ('A'-'Z', 'a'-'z' and '-').

Command and parameters must be separated by at least one space.

#### Parameters

A sequence of alphanumeric ASCII characters ('0'-'9', 'A'-'Z', 'a'-'z' and some special characters for specific commands). Parameters are separated by commas.

#### Message string

Every command entered as part of a message string begins with a **message starting character** and ends with a **message closing character**.

**Note:** A string can contain more than one command. Commands are separated by a pipe ( '|' ) character.

#### Message starting character

'#' – For host command/query

'~' – For device response

#### Device address (Optional, for K-NET)

K-NET Device ID followed by '@'

#### Query sign

'?' follows some commands to define a query request.

#### Message closing character

**CR** – For host messages; carriage return (ASCII 13)

**CRLF** – For device messages; carriage return (ASCII 13) + line-feed (ASCII 10)

#### Command chain separator character

When a message string contains more than one command, a pipe ( '|' ) character separates each command.

Spaces between parameters or command terms are ignored.

#### 14.1.4 Entering Commands

You can directly enter all commands using a terminal with ASCII communications software, such as HyperTerminal, Hercules, etc. Connect the terminal to the serial or Ethernet port on the Kramer device. To enter **CR** press the Enter key. (**LF** is also sent but is ignored by command parser).

For commands sent from some non-Kramer controllers, (for example, Crestron) some characters require special coding (such as, /X##). Refer to the controller manual.

#### 14.1.5 Command Forms

Some commands have short name syntax in addition to long name syntax to allow faster typing. The response is always in long syntax.

#### 14.1.6 Chaining Commands

Multiple commands can be chained in the same string. Each command is delimited by a pipe character (“|”). When chaining commands, enter the **message starting character** and the **message closing character** only once, at the beginning of the string and at the end.

Commands in the string do not execute until the closing character is entered. A separate response is sent for every command in the chain.

#### 14.1.7 Maximum String Length

64 characters

## 14.2 Kramer Protocol 3000 Commands

Full details for each command are presented in the Kramer Protocol 3000 document available for download from <http://www.kramerelectronics.com>.

| Command     | Description                                      |
|-------------|--|
| #           | Protocol handshaking                             |
| BUILD-DATE? | Read device build date                           |
| FACTORY     | Reset to factory default configuration           |
| HELP        | List of commands                                 |
| LOCK-FP     | Lock the front panel                             |
| MACH-NUM    | Sets the machine number                          |
| MODEL?      | Read device model                                |
| NAME        | Sets the machine (DNS) name                      |
| NET-DHCP    | Set DHCP mode                                    |
| NET-GATE    | Set Gateway                                      |
| NET-IP      | Set IP address                                   |
| NET-MAC?    | Read MAC address                                 |
| NET-MASK    | Set subnet mask                                  |
| PROT-VER?   | Read device protocol version                     |
| PRST-RCL    | Recall a saved preset list                       |
| PRST-STO    | Store the current connections, volumes and modes |
| PRST-VID?   | Get video connections from a saved preset        |
| RESET       | Reset device                                     |
| SIGNAL?     | Get input signal lock status                     |
| SN?         | Read device serial number                        |
| VERSION?    | Read device firmware version                     |
| VID         | Set video switch state                           |

| Command - #   |                      | Command Type - System-mandatory |              |
|---|----------------------|---------------------------------|--------------|
| Command Name  |                      | Permission                      | Transparency |
| Set:  | #                    | End User                        | Public       |
| Get:  | -                    | -                               | -            |
| Description   |                      | Syntax                          |              |
| Set:  | Protocol handshaking | # <input type="checkbox"/>      |              |
| Get:  | -                    | -                               |              |
| Response  |                      |                                 |              |
| ~nn@ <input type="checkbox"/> ok <input type="checkbox"/>               |                      |                                 |              |
| Parameters  |                      |                                 |              |
|   |                      |                                 |              |
| Response Triggers   |                      |                                 |              |
|   |                      |                                 |              |
| Notes   |                      |                                 |              |
| Use to validate the Protocol 3000 connection and get the machine number |                      |                                 |              |

| Command - BUILD-DATE  |                       | Command Type - System-mandatory      |              |
|---|-----------------------|--------------------------------------|--------------|
| Command Name  |                       | Permission                           | Transparency |
| Set:  | -                     | -                                    | -            |
| Get:  | BUILD-DATE?           | End User                             | Public       |
| Description   |                       | Syntax                               |              |
| Set:  | Get device build date | #BUILD-DATE <input type="checkbox"/> |              |
| Get:  | -                     | -                                    |              |
| Response  |                       |                                      |              |
| ~nn@BUILD-DATE <input type="checkbox"/> date <input type="checkbox"/> time <input type="checkbox"/>   |                       |                                      |              |
| Parameters  |                       |                                      |              |
| <i>date</i> - Format: YYYY/MM/DD where YYYY = Year, MM = Month, DD = Day<br><i>time</i> - Format: hh:mm:ss where hh = hours, mm = minutes, ss = seconds |                       |                                      |              |
| Response Triggers   |                       |                                      |              |
|   |                       |                                      |              |
| Notes   |                       |                                      |              |
|   |                       |                                      |              |



| Command - <b>FACTORY</b>   |   | Command Type - System-mandatory |              |
|--|---|---------------------------------|--------------|
| Command Name   |   | Permission                      | Transparency |
| Set:   | <b>FACTORY</b>                                | End User                        | Public       |
| Get:   | -   | -                               | -            |
| Description  |   | Syntax                          |              |
| Set:   | Reset device to factory default configuration | # <b>FACTORY</b> <sub>CR</sub>  |              |
| Get:   | -   | -                               |              |
| Response   |   |                                 |              |
| ~ <b>hn</b> @ <b>FACTORY</b> <sub>SP</sub> <b>OK</b> <sub>CR LF</sub>                |   |                                 |              |
| Parameters   |   |                                 |              |
|  |   |                                 |              |
| Response Triggers  |   |                                 |              |
|  |   |                                 |              |
| Notes  |   |                                 |              |
| This command deletes all user data from the device. The deletion can take some time. |   |                                 |              |

| Command - <b>HELP</b>  |   | Command Type - System-mandatory  |              |
|--|---|--|--------------|
| Command Name   |   | Permission   | Transparency |
| Set:   | -   | -  | -            |
| Get:   | <b>HELP</b>                                   | End User   | Public       |
| Description  |   | Syntax   |              |
| Set:   | -   | -  |              |
| Get:   | Get command list or help for specific command | 2 options:<br>1. # <b>HELP</b> <sub>CR</sub><br>2. # <b>HELP</b> <sub>SP</sub> <i>command_name</i> <sub>CR</sub> |              |
| Response   |   |  |              |
| <ul style="list-style-type: none"> <li>1. Multi-line: ~<b>hn</b>@<b>Device available protocol 3000</b><br/><b>commands:</b> <sub>CR LF</sub><i>command</i><sub>SP</sub><i>command...</i><sub>CR LF</sub></li> <li><b>To get help for command use: HELP (COMMAND_NAME)</b><sub>CR LF</sub></li> <li>2. Multi-line: ~<b>hn</b>@<b>HELP</b><sub>SP</sub><i>command:</i> <sub>CR LF</sub><i>description</i><sub>CR LF</sub><b>USAGE:</b> <i>usage</i><sub>CR LF</sub></li> </ul> |   |  |              |
| Parameters   |   |  |              |
|  |   |  |              |
| Response Triggers  |   |  |              |
|  |   |  |              |
| Notes  |   |  |              |
|  |   |  |              |

| Command - <b>MODEL?</b>  |                  | Command Type - System-mandatory |              |
|--|------------------|---------------------------------|--------------|
| Command Name   |                  | Permission                      | Transparency |
| Set:   | -                | -                               | -            |
| Get:   | <b>MODEL?</b>    | End User                        | Public       |
| Description  |                  | Syntax                          |              |
| Set:   | -                | -                               |              |
| Get:   | Get device model | # <b>MODEL?</b> <sub>CR</sub>   |              |
| Response   |                  |                                 |              |
| ~ <sub>hh</sub> @ <b>MODEL</b> <sub>SP</sub> model_name <sub>CR LF</sub> |                  |                                 |              |
| Parameters   |                  |                                 |              |
| model_name - String of up to 19 printable ASCII chars                    |                  |                                 |              |
| Response Triggers  |                  |                                 |              |
|  |                  |                                 |              |
| Notes  |                  |                                 |              |
|  |                  |                                 |              |

| Command - <b>PROT-VER?</b>  |                             | Command Type - System-mandatory  |              |
|---|-----------------------------|----------------------------------|--------------|
| Command Name  |                             | Permission                       | Transparency |
| Set:  | -                           | -                                | -            |
| Get:  | <b>PROT-VER?</b>            | End User                         | Public       |
| Description   |                             | Syntax                           |              |
| Set:  | -                           | -                                |              |
| Get:  | Get device protocol version | # <b>PROT-VER?</b> <sub>CR</sub> |              |
| Response  |                             |                                  |              |
| ~ <sub>hh</sub> @ <b>PROT-VER</b> <sub>SP</sub> 3000:version <sub>CR LF</sub> |                             |                                  |              |
| Parameters  |                             |                                  |              |
| Version - XX.XX where X is a decimal digit                                    |                             |                                  |              |
| Response Triggers   |                             |                                  |              |
|   |                             |                                  |              |
| Notes   |                             |                                  |              |
|   |                             |                                  |              |

| Command - <b>RESET</b>   |              | Command Type - System-mandatory         |              |
|--|--------------|---|--------------|
| Command Name   |              | Permission                              | Transparency |
| Set:   | <b>RESET</b> | Administrator                           | Public       |
| Get:   | -            | -                                       | -            |
| Description  |              | Syntax                                  |              |
| Set:   | Reset device | # <b>RESET</b> <input type="checkbox"/> |              |
| Get:   | -            | -                                       |              |
| Response   |              |   |              |
| ~ <input type="checkbox"/> @ <b>RESET</b> <input type="checkbox"/> OK <input type="checkbox"/>   |              |   |              |
| Parameters   |              |   |              |
|  |              |   |              |
| Response Triggers  |              |   |              |
|  |              |   |              |
| Notes  |              |   |              |
| To avoid locking the port due to a USB bug in Windows, disconnect USB connections immediately after running this command. If the port was locked, disconnect and reconnect the cable to reopen the port. |              |   |              |

| Command - <b>SN?</b>   |                          | Command Type - System-mandatory       |              |
|--|--------------------------|---------------------------------------|--------------|
| Command Name   |                          | Permission                            | Transparency |
| Set:   | -                        | -                                     | -            |
| Get:   | <b>SN?</b>               | End User                              | Public       |
| Description  |                          | Syntax                                |              |
| Set:   | -                        | -                                     |              |
| Get:   | Get device serial number | # <b>SN?</b> <input type="checkbox"/> |              |
| Response   |                          |                                       |              |
| ~ <input type="checkbox"/> @ <b>SN</b> <input type="checkbox"/> serial_number <input type="checkbox"/> |                          |                                       |              |
| Parameters   |                          |                                       |              |
| serial_number - 11 decimal digits, factory assigned  |                          |                                       |              |
| Response Triggers  |                          |                                       |              |
|  |                          |                                       |              |
| Notes  |                          |                                       |              |
| For new products with 14 digit serial numbers, use only the last 11 digits                             |                          |                                       |              |

| Command - <b>VERSION?</b>   |                             | Command Type - System-mandatory |              |
|---|-----------------------------|---------------------------------|--------------|
| Command Name  |                             | Permission                      | Transparency |
| Set:  | -                           | -                               | -            |
| Get:  | <b>VERSION?</b>             | End User                        | Public       |
| Description   |                             | Syntax                          |              |
| Set:  | -                           | -                               |              |
| Get:  | Get firmware version number | # <b>VERSION?</b> <sub>CR</sub> |              |
| Response  |                             |                                 |              |
| ~ <b>nn</b> @ <b>VERSION?</b> <sub>SP</sub> firmware_version <sub>CR LF</sub>       |                             |                                 |              |
| Parameters  |                             |                                 |              |
| firmware_version - XX.XX.XXXX where the digit groups are: major.minor.build version |                             |                                 |              |
| Response Triggers   |                             |                                 |              |
|   |                             |                                 |              |
| Notes   |                             |                                 |              |
|   |                             |                                 |              |

| Command - <b>LDFW</b>  |                        | System - Packets  |              |
|--|------------------------|---|--------------|
| Command Name   |                        | Permission  | Transparency |
| Set:   | <b>LDFW</b>            | Internal SW   | Public       |
| Get:   | -                      | -   | -            |
| Description  |                        | Syntax  |              |
| Set:   | Load new firmware file | Step 1: # <b>LDFW?</b> <sub>SP</sub> size <sub>CR</sub><br>Step 2: If ready was received, send <b>FIRMWARE_DATA</b> |              |
| Get:   | -                      | -   |              |
| Response   |                        |   |              |
| Response 1: ~ <b>nn</b> @ <b>LDFW?</b> <sub>SP</sub> size <sub>SP</sub> <b>READY</b> <sub>CR LF</sub> or ~ <b>nn</b> @ <b>LDFW?</b> <sub>SP</sub> <b>ERRnn</b> <sub>CR LF</sub>                |                        |   |              |
| Response 2: ~ <b>nn</b> @ <b>LDFW?</b> <sub>SP</sub> size <sub>SP</sub> <b>OK</b> <sub>CR LF</sub>   |                        |   |              |
| Parameters   |                        |   |              |
| size - size of firmware data that is sent<br><b>FIRMWARE_DATA</b> - HEX or KFW file in protocol packets (see <a href="#">Section 4</a> )   |                        |   |              |
| Response Triggers  |                        |   |              |
|  |                        |   |              |
| Notes  |                        |   |              |
| In most devices firmware data is saved to flash memory, but the memory does not update until receiving the "UPGRADE" command and is restarted.<br>Use this command in dedicated SW application |                        |   |              |

| Command - <b>NET-DHCP</b>   |   | Command Type - Communication |              |
|---|---|------------------------------|--------------|
| Command Name  |   | Permission                   | Transparency |
| Set:  | <b>NET-DHCP</b>                         | Administrator                | Public       |
| Get:  | <b>NET-DHCP?</b>                        | End User                     | Public       |
| Description   |   | Syntax                       |              |
| Set:  | Set DHCP mode                           | #NET-DHCP [SP] mode [CR]     |              |
| Get:  | Get DHCP mode                           | #NET-DHCP? [CR]              |              |
| Response  |   |                              |              |
| Set:  | ~nn@ NET-DHCP [SP] mode [SP] OK [CR LF] |                              |              |
| Get:  | ~nn@ NET-DHCP [SP] mode [CR LF]         |                              |              |
| Parameters  |   |                              |              |
| mode - 0 - Do not use DHCP. Use the IP set by the factory or using the IP set command<br>1 - Try to use DHCP. If unavailable, use IP as above   |   |                              |              |
| Response Triggers   |   |                              |              |
|   |   |                              |              |
| Notes   |   |                              |              |
| Connecting Ethernet to devices with DHCP may take more time in some networks<br>To connect with a randomly assigned IP by DHCP, specify the device DNS name (if available) using the command "NAME". You can also get an assigned IP by direct connection to USB or RS-232 protocol port if available<br>For proper settings consult your network administrator |   |                              |              |

| Command - <b>NET-GATE</b>  |  | Command Type - Communication   |              |
|--|--|--------------------------------|--------------|
| Command Name   |  | Permission                     | Transparency |
| Set:   | <b>NET-GATE</b>                              | Administrator                  | Public       |
| Get:   | <b>NET-GATE?</b>                             | End User                       | Public       |
| Description  |  | Syntax                         |              |
| Set:   | Set gateway IP                               | #NET-GATE [SP] ip_address [CR] |              |
| Get:   | Get gateway IP                               | #NET-GATE? [CR]                |              |
| Response   |  |                                |              |
| Set:   | ~nn@NET-GATE [SP] ip_address [SP] OK [CR LF] |                                |              |
| Get:   | ~nn@NET-GATE [SP] ip_address [CR LF]         |                                |              |
| Parameters   |  |                                |              |
| ip_address - format: xxx.xxx.xxx.xxx   |  |                                |              |
| Response Triggers  |  |                                |              |
|  |  |                                |              |
| Notes  |  |                                |              |
| A network gateway connects the device via another network and maybe over the Internet. Be careful of security problems. For proper settings consult your network administrator |  |                                |              |

| Command - <b>NET-IP</b>                                |   | Command Type - Communication                       |              |
|--|---|--|--------------|
| Command Name   |   | Permission   | Transparency |
| Set:   | <b>NET-IP</b>   | Administrator                                      | Public       |
| Get:   | <b>NET-IP?</b>  | End User   | Public       |
| Description  |   | Syntax   |              |
| Set:   | Set IP address  | #NET-IP <sub>[SP]</sub> ip_address <sub>[CR]</sub> |              |
| Get:   | Get IP address  | #NET-IP? <sub>[CR]</sub>                           |              |
| Response   |   |  |              |
| Set:   | ~nn@NET-IP <sub>[SP]</sub> ip_address <sub>[SP]</sub> OK <sub>[CR LF]</sub> |  |              |
| Get:   | ~nn@NET-IP <sub>[SP]</sub> ip_address <sub>[CR LF]</sub>                    |  |              |
| Parameters   |   |  |              |
| <i>ip_address</i> - format: xxx.xxx.xxx.xxx            |   |  |              |
| Response Triggers                                      |   |  |              |
|  |   |  |              |
| Notes  |   |  |              |
| For proper settings consult your network administrator |   |  |              |

| Command - <b>NET-MAC?</b>   |                 | Command Type - Communication |              |
|---|-----------------|------------------------------|--------------|
| Command Name  |                 | Permission                   | Transparency |
| Set:  | -               | -                            | -            |
| Get:  | <b>NET-MAC?</b> | End User                     | Public       |
| Description   |                 | Syntax                       |              |
| Set:  | -               | -                            |              |
| Get:  | Get MAC address | #NET-MAC? <sub>[CR]</sub>    |              |
| Response  |                 |                              |              |
| ~nn@NET-MAC <sub>[SP]</sub> mac_address <sub>[CR LF]</sub>                              |                 |                              |              |
| Parameters  |                 |                              |              |
| <i>mac_address</i> - Unique MAC address. Format: XX-XX-XX-XX-XX-XX where X is hex digit |                 |                              |              |
| Response Triggers   |                 |                              |              |
|   |                 |                              |              |
| Notes   |                 |                              |              |
|   |                 |                              |              |

| Command - <b>NET-MASK</b>   |   | Command Type - Communication                |              |
|---|---|---|--------------|
| Command Name  |   | Permission                                  | Transparency |
| Set:  | <b>NET-MASK</b>   | Administrator                               | Public       |
| Get:  | <b>NET-MASK?</b>  | End User                                    | Public       |
| Description   |   | Syntax                                      |              |
| Set:  | Set subnet mask   | # <b>NET-MASK</b> [SP] <i>net_mask</i> [CR] |              |
| Get:  | Get subnet mask   | # <b>NET-MASK?</b> [CR]                     |              |
| Response  |   |   |              |
| Set:  | ~ <b>nn</b> @ <b>NET-MASK</b> [SP] <i>net_mask</i> [SP] <b>OK</b> [CR LF] |   |              |
| Get:  | ~ <b>nn</b> @ <b>NET-MASK</b> [SP] <i>net_mask</i> [CR LF]                |   |              |
| Parameters  |   |   |              |
| <i>net_mask</i> - format: xxx.xxx.xxx.xxx   |   |   |              |
| Response Triggers   |   |   |              |
| The subnet mask limits the Ethernet connection within the local network<br>For proper settings consult your network administrator |   |   |              |
| Notes   |   |   |              |
|   |   |   |              |

| Command - <b>ETH-PORT</b>  |                            | Command Type - Communication                                  |              |
|--|----------------------------|---|--------------|
| Command Name   |                            | Permission  | Transparency |
| Set:   | <b>ETH-PORT</b>            | Administrator   | Public       |
| Get:   | <b>ETH-PORT?</b>           | End User  | Public       |
| Description  |                            | Syntax  |              |
| Set:   | Set Ethernet port protocol | # <b>ETH-PORT</b> [SP] <i>portType, ETHPort, portNum</i> [CR] |              |
| Get:   | Get Ethernet port protocol | # <b>ETH-PORT?</b> [SP] <i>portType, portNum</i> [CR]         |              |
| Response   |                            |   |              |
| ~ <b>nn</b> @ <b>ETH-PORT</b> [SP] <i>portType, ETHPort, portNum</i> [CR LF]   |                            |   |              |
| Parameters   |                            |   |              |
| <i>portNum</i> - 1-4 TCP/UDP port enumerator (equals the connected com port number from the tunneling port)<br><i>portType</i> - TCP/UDP<br><i>ETHPort</i> - TCP/UDP port number |                            |   |              |
| Response Triggers  |                            |   |              |
|  |                            |   |              |
| Notes  |                            |   |              |
|  |                            |   |              |

| Command - <b>LOCK-FP</b>  |                            | Command Type - System   |              |
|---|----------------------------|---|--------------|
| Command Name  |                            | Permission  | Transparency |
| Set:  | <b>LOCK-FP</b>             | End User  | Public       |
| Get:  | <b>LOCK-FP?</b>            | End User  | Public       |
| Description   |                            | Syntax  |              |
| Set:  | Lock front panel           | Option 1: # <b>LOCK-FP</b> <sub>[SP]</sub> /lock_mode <sub>[CR]</sub><br>Option 2: # <b>LOCK-FP</b> <sub>[SP]</sub> device_id,lock_mode <sub>[CR]</sub> |              |
| Get:  | Get front panel lock state | Option 1: # <b>LOCK-FP?</b> <sub>[CR]</sub><br>Option 2: # <b>LOCK-FP?</b> <sub>[SP]</sub> device_id <sub>[CR]</sub>                                    |              |
| Response  |                            |   |              |
| Set: Option 1: ~ <b>nn</b> @ <b>LOCK-FP</b> <sub>[SP]</sub> /lock_mode <sub>[SP]</sub> <b>OK</b> <sub>[CR LF]</sub><br>Option 2: ~01@ <b>LOCK-FP</b> <sub>[SP]</sub> device_id,lock_mode <sub>[SP]</sub> <b>OK</b> <sub>[CR LF]</sub> |                            |   |              |
| Get: Option 1: ~ <b>nn</b> @ <b>LOCK-FP</b> <sub>[SP]</sub> /lock_mode <sub>[CR LF]</sub><br>Option 2: ~01@ <b>LOCK-FP</b> <sub>[SP]</sub> device_id, lock_mode <sub>[CR LF]</sub>  |                            |   |              |
| Parameters  |                            |   |              |
| lock_mode - 0/OFF - unlocks the front panel buttons, 1/ON - locks the front panel buttons<br>device_id - for K-Net controllers, select the button panel to lock. Locking is allowed only from the master                              |                            |   |              |
| Response Triggers   |                            |   |              |
|   |                            |   |              |
| Notes   |                            |   |              |
|   |                            |   |              |

| Command - <b>MACH-NUM</b>   |                    | Command Type - System  |              |
|---|--------------------|--|--------------|
| Command Name  |                    | Permission   | Transparency |
| Set:  | <b>MACH-NUM</b>    | End User   | Public       |
| Get:  | -                  | -  | -            |
| Description   |                    | Syntax   |              |
| Set:  | Set machine number | # <b>MACH-NUM</b> <sub>[SP]</sub> machine_number <sub>[CR]</sub> |              |
| Get:  | -                  | -  |              |
| Response  |                    |  |              |
| ~ <b>nn</b> @ <b>MACH-NUM</b> <sub>[SP]</sub> machine_number <sub>[CR LF]</sub> <b>OK</b> <sub>[CR LF]</sub>                                      |                    |  |              |
| Parameters  |                    |  |              |
| machine_number - new device machine number  |                    |  |              |
| Response Triggers   |                    |  |              |
|   |                    |  |              |
| Notes   |                    |  |              |
| Some devices do not set the new machine number until the device is restarted<br>Some devices can change the machine number only from DIP-switches |                    |  |              |



| Command - <b>NAME</b>   |  | Command Type - System (Ethernet)                                  |              |
|---|--|---|--------------|
| Command Name  |  | Permission  | Transparency |
| Set:  | <b>NAME</b>  | Administrator   | Public       |
| Get:  | <b>NAME?</b>   | End User  | Public       |
| Description   |  | Syntax  |              |
| Set:  | Set machine (DNS) name   | # <b>NAME</b> <sub>[SP]</sub> <i>machine_name</i> <sub>[CR]</sub> |              |
| Get:  | Get machine (DNS) name   | # <b>NAME?</b> <sub>[CR]</sub>                                    |              |
| Response  |  |   |              |
| Set:  | ~ <b>nn</b> @ <b>NAME</b> <sub>[SP]</sub> <i>machine_name</i> <sub>[SP]</sub> <b>OK</b> <sub>[CR LF]</sub> |   |              |
| Get:  | ~ <b>nn</b> @ <b>NAME?</b> <sub>[SP]</sub> <i>machine_name</i> <sub>[CR LF]</sub>                          |   |              |
| Parameters  |  |   |              |
| <i>machine_name</i> - String of up to 14 alpha-numeric chars (can include hyphen, not at the beginning or end)  |  |   |              |
| Response Triggers   |  |   |              |
|   |  |   |              |
| Notes   |  |   |              |
| The machine name is not the same as the model name. The machine name is used to identify a specific machine or a network in use (with DNS feature on) |  |   |              |

| Command - <b>PRST-RCL</b>  |                          | Command Type - System   |              |
|--|--------------------------|---|--------------|
| Command Name   |                          | Permission  | Transparency |
| Set:   | <b>PRST-RCL</b>          | End User  | Public       |
| Get:   | -                        | -   | -            |
| Description  |                          | Syntax  |              |
| Set:   | Recall saved preset list | # <b>PRST-RCL</b> <sub>[SP]</sub> <i>preset</i> <sub>[CR]</sub> |              |
| Get:   | -                        | -   |              |
| Response   |                          |   |              |
| ~ <b>nn</b> @ <b>PRST-RCL</b> <sub>[SP]</sub> <i>preset</i> <sub>[CR LF]</sub>   |                          |   |              |
| Parameters   |                          |   |              |
| <i>preset</i> - preset number  |                          |   |              |
| Response Triggers  |                          |   |              |
|  |                          |   |              |
| Notes  |                          |   |              |
| In most units, video and audio presets with the same number are stored and recalled together by commands #PRST-STO and #PRST-RCL |                          |   |              |

| Command - <b>PRST-STO</b>  |  | Command Type - System                                       |              |
|--|--|---|--------------|
| Command Name   |  | Permission  | Transparency |
| Set:   | <b>PRST-STO</b>  | End User  | Public       |
| Get:   | -  | -   | -            |
| Description  |  | Syntax  |              |
| Set:   | Store current connections, volumes and modes in preset | # <b>PRST-STO</b> <sub>SP</sub> <i>preset</i> <sub>CR</sub> |              |
| Get:   | -  | -   |              |
| Response   |  |   |              |
| ~ <sub>hh</sub> @ <b>PRST-STO</b> <sub>SP</sub> <i>preset</i> <sub>CR LF</sub>   |  |   |              |
| Parameters   |  |   |              |
| <i>preset</i> - preset number  |  |   |              |
| Response Triggers  |  |   |              |
|  |  |   |              |
| Notes  |  |   |              |
| In most units, video and audio presets with the same number are stored and recalled together by commands #PRST-STO and #PRST-RCL |  |   |              |

| Command - <b>PRST-VID?</b>  |  | Command Type - System   |              |
|---|--|---|--------------|
| Command Name  |  | Permission  | Transparency |
| Set:  | -  | -   | -            |
| Get:  | <b>PRST-VID?</b>                               | End User  | Public       |
| Description   |  | Syntax  |              |
| Set:  | -  | -   |              |
| Get:  | Get video connections from saved preset        | #PRST-VID? <input type="text" value="SP"/> preset, <input type="text" value="out"/> <input type="text" value="CR"/><br>#PRST-VID? <input type="text" value="SP"/> preset, * <input type="text" value="CR"/> |              |
| Response  |  |   |              |
| ~ <input type="text" value="nn"/> @PRST-VID <input type="text" value="SP"/> preset, in> <input type="text" value="out"/> <input type="text" value="CR LF"/>   |  |   |              |
| ~ <input type="text" value="nn"/> @PRST-VID <input type="text" value="SP"/> preset, in>1, in>2, in>3, ... <input type="text" value="CR LF"/>  |  |   |              |
| Parameters  |  |   |              |
| <p><i>preset</i> - preset number<br/> <i>n</i> - input number or '0' if output disconnected<br/> &gt; - connection character between in and out parameters<br/> <i>out</i> - output number or '*' for all outputs</p> |  |   |              |
| Response Triggers   |  |   |              |
|   |  |   |              |
| Notes   |  |   |              |
| In most units, video and audio presets with the same number are stored and recalled together by commands #PRST-STO and #PRST-RCL  |  |   |              |
| Examples  |  |   |              |
| Store current audio and video connections, volumes and modes to preset 5  | #PRST-STO 5 <input type="text" value="CR"/>    | ~PRST-STO 5 <input type="text" value="CR LF"/>  |              |
| Recall audio and video connections from preset 3  | #PRCL 3 <input type="text" value="CR"/>        | ~PRST-RCL 3 <input type="text" value="CR LF"/>  |              |
| Show source of video output 2 from preset 3   | #PRST-VID? 3,2 <input type="text" value="CR"/> | ~PRST-VID 3, 4>2 <input type="text" value="CR LF"/>   |              |

| Command - <b>SIGNAL</b>  |                              | Command Type - System                                      |              |
|--|------------------------------|--|--------------|
| Command Name   |                              | Permission   | Transparency |
| Set:   | -                            | -  | -            |
| Get  | <b>SIGNAL?</b>               | End User   | Public       |
| Description  |                              | Syntax   |              |
| Set:   | -                            | -  |              |
| Get:   | Get input signal lock status | # <b>SIGNAL?</b> <sub>SP</sub> <i>inp_id</i> <sub>CR</sub> |              |
| Response   |                              |  |              |
| - <b>nn</b> @ <b>SIGNAL</b> <sub>SP</sub> <i>inp_id,status</i> <sub>CR LF</sub>                                    |                              |  |              |
| Parameters   |                              |  |              |
| <i>inp_id</i> - input number   |                              |  |              |
| <i>status</i> - lock status according to signal validation (see <a href="#">Section 14.2.2 Signal Validation</a> ) |                              |  |              |
| Response Triggers  |                              |  |              |
| After execution, a response is sent to the com port from which the Get was received                                |                              |  |              |
| Response is sent after every change in input signal status ON to OFF, or OFF to ON                                 |                              |  |              |
| Notes  |                              |  |              |
|  |                              |  |              |

| Command - VID   |   | Command Type - Switch   |              |
|---|---|---|--------------|
| Command Name  |   | Permission  | Transparency |
| Set:  | <b>VID</b>  | End User  | Public       |
| Get:  | <b>VID?</b>   | End User  | Public       |
| Description   |   | Syntax  |              |
| Set:  | Set video switch state  | #VID[SP]in>out, in>out,...[CR]  |              |
| Get:  | Get video switch state  | #VID?[SP]out[CR]<br>#VID?[SP]*[CR]  |              |
| Response  |   |   |              |
| Set:  | ~nn@VID[SP]in>out[CR LF]<br>~nn@VID[SP]in>out[CR LF] ...  |   |              |
| Get:  | ~nn@VID[SP]in>out[CR LF]<br>~nn@VID[SP]in>1, in>2, ... [CR LF]  |   |              |
| Parameters  |   |   |              |
| in - input number or '0' to disconnect output<br>> - connection character between in and out parameters<br>out - output number or '*' for all outputs |   |   |              |
| Response Triggers   |   |   |              |
| Notes   |   |   |              |
| When AFV switching mode is active, this command also switches audio and the unit replies with command ~AV.  |   |   |              |
| Examples  |   |   |              |
| When AFV switching mode is active, this command also switches audio and the unit replies with command ~AV.  |   |   |              |
| Switch video and audio input 3 to output 7  | #AV 3>7[CR]   | ~01@AV 3>7[CRLF]  |              |
| Switch video input 2 to output 4  | #V 2>4[CR]  | ~01@VID 2>4[CRLF]   |              |
| Switch video input 4 to output 2 in machine 6   | #6@VID 4>2[CR]  | ~06@VID 4>2[CRLF]   |              |
| Disconnect video and audio output 4   | #AV 0>4[CR]   | ~01@AV 0>4[CRLF]  |              |
| Switch video input 3 to all outputs   | #V 3>*[CR]  | ~01@VID 3>*[CRLF]   |              |
| Chaining multiple commands  | #AV 1>*   V 3>4, 2>2, 2>1, 0>2   V 3>9   A 0>1   V? * [CR]<br>1. Switch audio and video from input 1 to all outputs<br>2. Switch video input 3 to output 4, video input 2 to output 2, video input 2 to output 1 and disconnect video output 2<br>3. Switch video input 3 to output 9 (non-existent)<br>4. Disconnect audio output 1<br>5. Get status of all video links<br>Command processing begins after entering [CR]<br>A response is sent for each command after processing | ~AV 1>*[CRLF]<br>~VID 3>4[CRLF]<br>~VID 2>2[CRLF]<br>~VID 2>1[CRLF]<br>~VID 0>2[CRLF]<br><br>~VID ERR003[CRLF]<br>~AUD 0>1[CRLF]<br>~VID 2>1, 0>2, 1>3, 3>4[CRLF] |              |

## 14.2.1 Video Resolutions

| VIC Number | Resolution   |
|------------|--|
| 0          | No Signal (for input) / Native - EDID (for output) |
| 1          | 640x480p @59.94Hz/60Hz                             |
| 2          | 720x480p @59.94Hz/60Hz                             |
| 3          | 720x480p @59.94Hz/60Hz                             |
| 4          | 1280x720p @59.94Hz/60Hz                            |
| 5          | 1920x1080i @59.94Hz/60Hz                           |
| 6          | 720(1440)x480i @59.94Hz/60Hz                       |
| 7          | 720(1440)x480i @59.94Hz/60Hz                       |
| 8          | 720(1440)x240p @59.94Hz/60Hz                       |
| 9          | 720(1440)x240p @59.94Hz/60Hz                       |
| 10         | 2880x480i @59.94Hz/60Hz                            |
| 11         | 2880x480i @59.94Hz/60Hz                            |
| 12         | 2880x240p @59.94Hz/60Hz                            |
| 13         | 2880x240p @59.94Hz/60Hz                            |
| 14         | 1440x480p @59.94Hz/60Hz                            |
| 15         | 1440x480p @59.94Hz/60Hz                            |
| 16         | 1920x1080p @59.94Hz/60Hz                           |
| 17         | 720x576p @50Hz                                     |
| 18         | 720x576p @50Hz                                     |
| 19         | 1280x720p @50Hz                                    |
| 20         | 1920x1080i @50Hz                                   |
| 21         | 720(1440)x576i @50Hz                               |
| 22         | 720(1440)x576i @50Hz                               |
| 23         | 720(1440)x288p @50Hz                               |
| 24         | 720(1440)x288p @50Hz                               |
| 25         | 2880x576i @50Hz                                    |
| 26         | 2880x576i @50Hz                                    |
| 27         | 2880x288p @50Hz                                    |
| 28         | 2880x288p @50Hz                                    |
| 29         | 1440x576p @50Hz                                    |
| 30         | 1440x576p @50Hz                                    |
| 31         | 1920x1080p @50Hz                                   |
| 32         | 1920x1080p @23.97Hz/24Hz                           |
| 33         | 1920x1080p @25Hz                                   |
| 34         | 1920x1080p @29.97Hz/30Hz                           |
| 35         | 2880x480p @59.94Hz/60Hz                            |
| 36         | 2880x480p @59.94Hz/60Hz                            |
| 37         | 2880x576p @50Hz                                    |
| 38         | 2880x576p @50Hz                                    |
| 39         | 1920x1080i @50Hz                                   |

| VIC Number | Resolution                   |
|------------|------------------------------|
| 40         | 1920x1080i @100Hz            |
| 41         | 1280x720p @100Hz             |
| 42         | 720x576p @100Hz              |
| 43         | 720x576p @100Hz              |
| 44         | 720(1440)x576i @100Hz        |
| 45         | 720(1440)x576i @100Hz        |
| 46         | 1920x1080i @119.88/120Hz     |
| 47         | 1280x720p @119.88/120Hz      |
| 48         | 720x480p @119.88/120Hz       |
| 49         | 720x480p @119.88/120Hz       |
| 50         | 720(1440)x480i @119.88/120Hz |
| 51         | 720(1440)x480i @119.88/120Hz |
| 52         | 720x576p @200Hz              |
| 53         | 720x576p @200Hz              |
| 54         | 720(1440)x576i @200Hz        |
| 55         | 720(1440)x576i @200Hz        |
| 56         | 720x480p @239.76/240Hz       |
| 57         | 720x480p @239.76/240Hz       |
| 58         | 720(1440)x480i @239.76/240Hz |
| 59         | 720(1440)x480i @239.76/240Hz |
| 60         | 1280x720p @23.97Hz/24Hz      |
| 61         | 1280x720p @25Hz              |
| 62         | 1280x720p @29.97Hz/30Hz      |
| 63         | 1920x1080p @119.88/120Hz     |
| 64         | 1920x1080p @100Hz            |
| 65-100     | (Reserved)                   |
| 100        | Custom resolution 1          |
| 101        | Custom resolution 2          |
| 102        | Custom resolution 3          |
| 103        | Custom resolution 4          |
| 104        | Custom resolution 5          |
| 104-254    | (Reserved)                   |
| 6          | Underscan 1                  |

### 14.2.2 Signal Validation

| Number | Value                       |
|--------|-----------------------------|
| 0      | Signal or sink is not valid |
| 1      | Signal or sink is valid     |
| 2      | Sink and EDID is valid      |

### 14.2.3 Ethernet Port Types

| Number | Value |
|--------|-------|
| 0      | TCP   |
| 1      | UDP   |



## LIMITED WARRANTY

The warranty obligations of Kramer Electronics for this product are limited to the terms set forth below:

### What is Covered

This limited warranty covers defects in materials and workmanship in this product.

### What is Not Covered

This limited warranty does not cover any damage, deterioration or malfunction resulting from any alteration, modification, improper or unreasonable use or maintenance, misuse, abuse, accident, neglect, exposure to excess moisture, fire, improper packing and shipping (such claims must be presented to the carrier), lightning, power surges, or other acts of nature. This limited warranty does not cover any damage, deterioration or malfunction resulting from the installation or removal of this product from any installation, any unauthorized tampering with this product, any repairs attempted by anyone unauthorized by Kramer Electronics to make such repairs, or any other cause which does not relate directly to a defect in materials and/or workmanship of this product. This limited warranty does not cover cartons, equipment enclosures, cables or accessories used in conjunction with this product.

Without limiting any other exclusion herein, Kramer Electronics does not warrant that the product covered hereby, including, without limitation, the technology and/or integrated circuit(s) included in the product, will not become obsolete or that such items are or will remain compatible with any other product or technology with which the product may be used.

### How Long Does this Coverage Last

Seven years as of this printing; please check our Web site for the most current and accurate warranty information.

### Who is Covered

Only the original purchaser of this product is covered under this limited warranty. This limited warranty is not transferable to subsequent purchasers or owners of this product.

### What Kramer Electronics will do

Kramer Electronics will, at its sole option, provide one of the following three remedies to whatever extent it shall deem necessary to satisfy a proper claim under this limited warranty:

1. Elect to repair or facilitate the repair of any defective parts within a reasonable period of time, free of any charge for the necessary parts and labor to complete the repair and restore this product to its proper operating condition. Kramer Electronics will also pay the shipping costs necessary to return this product once the repair is complete.
2. Replace this product with a direct replacement or with a similar product deemed by Kramer Electronics to perform substantially the same function as the original product.
3. Issue a refund of the original purchase price less depreciation to be determined based on the age of the product at the time remedy is sought under this limited warranty.

### What Kramer Electronics will not do Under This Limited Warranty

If this product is returned to Kramer Electronics or the authorized dealer from which it was purchased or any other party authorized to repair Kramer Electronics products, this product must be insured during shipment, with the insurance and shipping charges prepaid by you. If this product is returned uninsured, you assume all risks of loss or damage during shipment. Kramer Electronics will not be responsible for any costs related to the removal or re-installation of this product from or into any installation. Kramer Electronics will not be responsible for any costs related to any setting up this product, any adjustment of user controls or any programming required for a specific installation of this product.

### How to Obtain a Remedy under this Limited Warranty

To obtain a remedy under this limited warranty, you must contact either the authorized Kramer Electronics reseller from whom you purchased this product or the Kramer Electronics office nearest you. For a list of authorized Kramer Electronics resellers and/or Kramer Electronics authorized service providers, please visit our web site at [www.kramerelectronics.com](http://www.kramerelectronics.com) or contact the Kramer Electronics office nearest you.

In order to pursue any remedy under this limited warranty, you must possess an original, dated receipt as proof of purchase from an authorized Kramer Electronics reseller. If this product is returned under this limited warranty, a return authorization number, obtained from Kramer Electronics, will be required. You may also be directed to an authorized reseller or a person authorized by Kramer Electronics to repair the product.

If it is decided that this product should be returned directly to Kramer Electronics, this product should be properly packed, preferably in the original carton, for shipping. Cartons not bearing a return authorization number will be refused.

### Limitation on Liability

THE MAXIMUM LIABILITY OF KRAMER ELECTRONICS UNDER THIS LIMITED WARRANTY SHALL NOT EXCEED THE ACTUAL PURCHASE PRICE PAID FOR THE PRODUCT. TO THE MAXIMUM EXTENT PERMITTED BY LAW, KRAMER ELECTRONICS IS NOT RESPONSIBLE FOR DIRECT, SPECIAL, INCIDENTAL OR CONSEQUENTIAL DAMAGES RESULTING FROM ANY BREACH OF WARRANTY OR CONDITION, OR UNDER ANY OTHER LEGAL THEORY. Some countries, districts or states do not allow the exclusion or limitation of relief, special, incidental, consequential or indirect damages, or the limitation of liability to specified amounts, so the above limitations or exclusions may not apply to you.

### Exclusive Remedy

TO THE MAXIMUM EXTENT PERMITTED BY LAW, THIS LIMITED WARRANTY AND THE REMEDIES SET FORTH ABOVE ARE EXCLUSIVE AND IN LIEU OF ALL OTHER WARRANTIES, REMEDIES AND CONDITIONS, WHETHER ORAL OR WRITTEN, EXPRESS OR IMPLIED. TO THE MAXIMUM EXTENT PERMITTED BY LAW, KRAMER ELECTRONICS SPECIFICALLY DISCLAIMS ANY AND ALL IMPLIED WARRANTIES, INCLUDING, WITHOUT LIMITATION, WARRANTIES OF MERCHANTABILITY AND FITNESS FOR A PARTICULAR PURPOSE. IF KRAMER ELECTRONICS CANNOT LAWFULLY DISCLAIM OR EXCLUDE IMPLIED WARRANTIES UNDER APPLICABLE LAW, THEN ALL IMPLIED WARRANTIES COVERING THIS PRODUCT, INCLUDING WARRANTIES OF MERCHANTABILITY AND FITNESS FOR A PARTICULAR PURPOSE, SHALL APPLY TO THIS PRODUCT AS PROVIDED UNDER APPLICABLE LAW.

IF ANY PRODUCT TO WHICH THIS LIMITED WARRANTY APPLIES IS A "CONSUMER PRODUCT" UNDER THE MAGNUSON-MOSS WARRANTY ACT (15 U.S.C.A. §2301, ET SEQ.) OR OTHER APPLICABLE LAW, THE FOREGOING DISCLAIMER OF IMPLIED WARRANTIES SHALL NOT APPLY TO YOU, AND ALL IMPLIED WARRANTIES ON THIS PRODUCT, INCLUDING WARRANTIES OF MERCHANTABILITY AND FITNESS FOR THE PARTICULAR PURPOSE, SHALL APPLY AS PROVIDED UNDER APPLICABLE LAW.

### Other Conditions

This limited warranty gives you specific legal rights, and you may have other rights which vary from country to country or state to state.

This limited warranty is void if (i) the label bearing the serial number of this product has been removed or defaced, (ii) the product is not distributed by Kramer Electronics or (iii) this product is not purchased from an authorized Kramer Electronics reseller. If you are unsure whether a reseller is an authorized Kramer Electronics reseller, please visit our Web site at [www.kramerelectronics.com](http://www.kramerelectronics.com) or contact a Kramer Electronics office from the list at the end of this document.

Your rights under this limited warranty are not diminished if you do not complete and return the product registration form or complete and submit the online product registration form. Kramer Electronics thanks you for purchasing a Kramer Electronics product. We hope it will give you years of satisfaction.



For the latest information on our products and a list of Kramer distributors, visit our Web site where updates to this user manual may be found.

**We welcome your questions, comments, and feedback.**

Web site: [www.kramerelectronics.com](http://www.kramerelectronics.com)

E-mail: [info@kramerel.com](mailto:info@kramerel.com)

CE



**SAFETY WARNING**

Disconnect the unit from the power supply before opening and servicing



P/N: 2900-300275



Rev: 1