

**Kramer Electronics, Ltd.**



# **USER MANUAL**

**Rack Adapter Model:**

**RK-1**

## Contents

<b>1</b>	<b>Introduction</b>	<b>1</b>
<b>2</b>	<b>Getting Started</b>	<b>1</b>
<b>3</b>	<b>Overview</b>	<b>1</b>
3.1	RK-1 Installation combinations	2
3.1.1	Using Blank Panels	3
3.2	Recommendations for Best Performance	4
<b>4</b>	<b>Your Kramer RK-1 Rack Adapter</b>	<b>5</b>
<b>5</b>	<b>Mounting on the Kramer RK-1 Rack Adapter</b>	<b>6</b>
5.1	Mounting Units that do not have Underside Screw Holes	7
5.2	Connecting a Blank Panel to the RK-1	9
<b>6</b>	<b>Technical Specifications</b>	<b>9</b>

## Figures

Figure 1:	RK-1 Rack Adapter	5
Figure 2:	RK-1 Rack Adapter – Underside	6
Figure 3:	Mounting a half-19" unit via Screws on the RK-1 Side Panel	7
Figure 4:	Mounting a 6.5" Machine via Screws on the RK-1 Side Panel 104B (FC-31xl)	8
Figure 5:	RK-1 Rack Adapter – Connecting a Blank Panel	9

## Tables

Table 1:	Using the RK-1	2
Table 2:	Using the RK-1 for 6.5"-1U Units	3
Table 3:	RK-1 Blank Panels – Part Numbers	3
Table 4:	Using the RK-1 with Blank Panels	4
Table 5:	Technical Specifications of the RK-1	9

## 1 Introduction

Welcome to Kramer Electronics! Since 1981, Kramer Electronics has been providing a world of unique, creative, and affordable solutions to the vast range of problems that confront the video, audio, presentation, and broadcasting professional on a daily basis. In recent years, we have redesigned and upgraded most of our line, making the best even better! Our 1,000-plus different models now appear in 11 groups<sup>1</sup> that are clearly defined by function.

Congratulations on purchasing your Kramer **RK-1** rack adapter, which is ideal for mounting combinations of several 1U Kramer products in a 19" rack. These include 1/2-19" 1U units, 1/4-19" 1U units, 1/8-19" 1U units and separately, up to two 6.5"-1U units.

The package includes the following items:

- **RK-1 Rack Adapter**
- Additional mechanical parts (blank panel<sup>2</sup>, screws, nuts and so on)
- This user manual<sup>3</sup>

## 2 Getting Started

We recommend that you:

- Unpack the equipment carefully and save the original box and packaging materials for possible future shipment
- Review the contents of this user manual

## 3 Overview

You can mount a combination of several Kramer products, of various widths, in a 19" 1U rack using the **RK-1** rack adapter. These include:

- 1/2-19" 1U units—for example, two **VP-5xl** units (see [Table 1](#))
- 1/4-19" 1U units—for example, four **FC-31xl** units, two **FC-31xl** units with one **VP-5xl** unit (see [Table 1](#))
- 1/8-19" 1U units—for example, eight **PS-1DVI** units (see [Table 1](#))

---

<sup>1</sup> GROUP 1: Distribution Amplifiers; GROUP 2: Switchers and Matrix Switchers; GROUP 3: Control Systems; GROUP 4: Format/Standards Converters; GROUP 5: Range Extenders and Repeaters; GROUP 6: Specialty AV Products; GROUP 7: Scan Converters and Scalers; GROUP 8: Cables and Connectors; GROUP 9: Room Connectivity; GROUP 10: Accessories and Rack Adapters; GROUP 11: Sierra Products

<sup>2</sup> One half-19" blank panel (P/N: 60-900013)

<sup>3</sup> Download up-to-date Kramer user manuals from the Internet at this URL: <http://www.kramerelectronics.com>

- 6.5"-1U units—for example, two **VM-50V** units with a short blank panel in between them, or one **VM-50V** unit with a short blank panel and a long blank panel (see [Table 2](#))

### 3.1 RK-1 Installation combinations

[Table 1](#) shows examples of how you can use the **RK-1** to mount different combinations of products:

*Table 1: Using the RK-1*

Mounting Kramer Products <sup>1</sup> on the RK-1		For example:						
1/2	1/2	<ul style="list-style-type: none"> <li>• Two PIP-4 units</li> <li>• Two VP-5xl units</li> </ul>						
1/2	1/4	1/4	<ul style="list-style-type: none"> <li>• One PIP-4 unit</li> <li>• Two FC-31xl units</li> </ul>					
1/2	1/4	1/8	1/8	<ul style="list-style-type: none"> <li>• One PIP-4 unit</li> <li>• One FC-31xl unit</li> <li>• One PS-1DVI unit</li> <li>• One PT-1PS unit</li> </ul>				
1/2	1/8	1/8	1/8	1/8	<ul style="list-style-type: none"> <li>• One PIP-4 unit</li> <li>• Two PS-1DVI units</li> <li>• Two PT-1PS units</li> </ul>			
1/4	1/4	1/4	1/4	<ul style="list-style-type: none"> <li>• Two FC-31xl units</li> <li>• Two 102xl units</li> </ul>				
1/4	1/4	1/4	1/8	1/8	<ul style="list-style-type: none"> <li>• Two FC-31xl units</li> <li>• One 102xl unit</li> <li>• Two PS-1DVI units</li> </ul>			
1/4	1/4	1/8	1/8	1/8	1/8	<ul style="list-style-type: none"> <li>• Two 102xl units</li> <li>• Two PS-1DVI units</li> <li>• Two PT-1PS units</li> </ul>		
1/4	1/8	1/8	1/8	1/8	1/8	1/8	<ul style="list-style-type: none"> <li>• One FC-31xl unit</li> <li>• Three PS-1DVI units</li> <li>• Three PT-1PS units</li> </ul>	
1/8	1/8	1/8	1/8	1/8	1/8	1/8	1/8	<ul style="list-style-type: none"> <li>• Four PS-1DVI units</li> <li>• Four PT-1PS units</li> </ul>

<sup>1</sup> Each product is measured in inches

You can mount one or two Kramer 6.5” products in a 19” 1U rack using the **RK-1** rack adapter (see in [Table 2](#)) and close-up the empty space(s) with blank panels (see in [Table 3](#)).



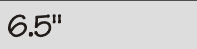

Table 2: Using the RK-1 for 6.5"-1U Units

Mounting Kramer 6.5"-1U products on the RK-1	For example:	Notes:
	<ul style="list-style-type: none"> <li>• One VM-50V unit</li> <li>• One VA-50P unit</li> </ul>	The gap between the units is closed with the short blank panel, see <a href="#">Table 3</a>
	<ul style="list-style-type: none"> <li>• One VM-30AV unit</li> </ul>	The opening is closed with one long blank panel and one short blank panel, see <a href="#">Table 3</a>

### 3.1.1 Using Blank Panels

[Table 3](#) defines the different types of blank panels that are available and are used to cover-up gaps.

Table 3: RK-1 Blank Panels – Part Numbers

Appearance	Blank Panel Description	Part Number
	PNL-BLANK/1/2U-19"	60-900013
	PNL-BLANK/1/4U-19"	60-900014
	PNL-BLANK/1/8U-19"	60-900015
<b>For 6.5"-1U units only:</b>		
	PNL-BLANK/SHORT6.5"1U <sup>1</sup>	60-900016
	PNL-BLANK/LONG6.5"1U <sup>2</sup>	60-900017

1 Use when mounting two units

2 Use when mounting one unit together with one SHORT unit

The examples in [Table 4](#) indicate how to install different products together with blanks:

Table 4: Using the RK-1 with Blank Panels

Mounting Kramer Products with Blank Panels on the RK-1		For example:		
1/2	1/2 Blank	<ul style="list-style-type: none"> <li>• One PIP-4 unit</li> <li>• One 1/2 19" blank panel</li> </ul>		
1/2 Blank	1/4 Blank	1/4	<ul style="list-style-type: none"> <li>• One 1/2 19" blank panel</li> <li>• One 1/4 19" blank panel</li> <li>• One FC-31xl unit</li> </ul>	
1/2	1/4	1/8 Blank	1/8	<ul style="list-style-type: none"> <li>• One PIP-4 unit</li> <li>• One FC-31xl unit</li> <li>• One 1/8 19" blank panel</li> <li>• One PT-1PS unit</li> </ul>
6.5"	SHORT Blank	LONG Blank	<ul style="list-style-type: none"> <li>• One VM-50V unit</li> <li>• One SHORT blank panel</li> <li>• One LONG blank panel</li> </ul>	
6.5"	SHORT Blank	6.5"	<ul style="list-style-type: none"> <li>• One VM-50V unit</li> <li>• One SHORT blank panel</li> <li>• One VM-50AN unit</li> </ul>	

### 3.2 Recommendations for Best Performance

We recommend that you:

- Have a Philips screwdriver and an Allen screwdriver available
- Disconnect the mains voltage and all cables connected to each machine that is being mounted in the rack adapter before proceeding with the installation
- Connect only good quality connection cables, thus avoiding interference, deterioration in signal quality due to poor matching, and elevated noise levels (often associated with low quality cables)
- Avoid interference from neighboring electrical appliances and position your rack adapter on the rack away from moisture, excessive sunlight and dust

## 4 Your Kramer RK-1 Rack Adapter

The example in [Figure 1](#) illustrates the mounting of:

- One 1/2-19" unit (for example, the Kramer **PIP-4**)
- One 1/4-19" 1U unit (for example, the Kramer MultiTOOLS® **FC-31xl**)
- Two 1/8-19" 1U units (for example, two Kramer MultiTOOLS® **PS-1DVI**)

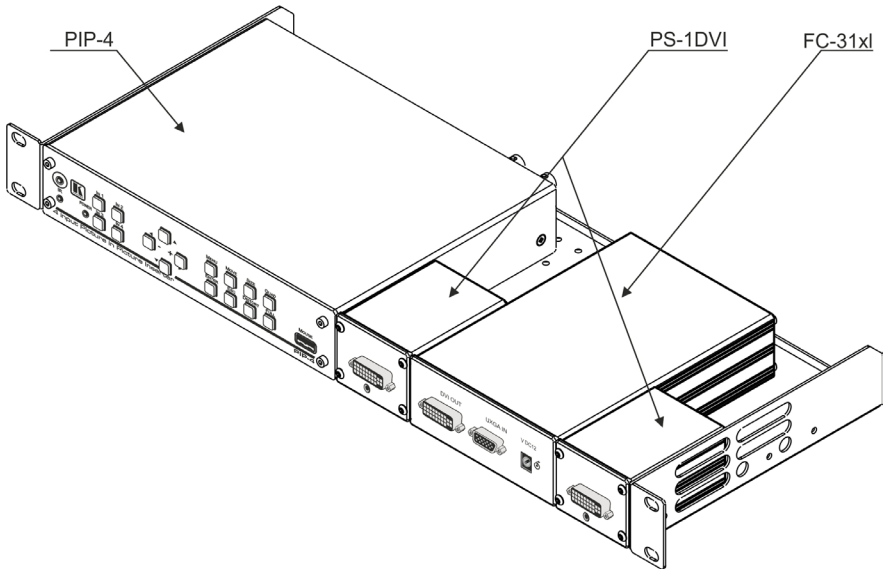

*Figure 1: RK-1 Rack Adapter*

You can order additional blank panels to cover a 1/4-19" 1U opening<sup>1</sup> and/or a 1/8-19" 1U opening<sup>2</sup> on the **RK-1**

<sup>1</sup> Part number 60-900014

<sup>2</sup> Part number 60-900015

## 5 Mounting on the Kramer RK-1 Rack Adapter

The **RK-1** underside includes a set of screw holes that are suitable for any combination of units to be mounted.

To mount the units on the **RK-1**, as illustrated in [Figure 1](#), do the following:

1. Place the first unit on the rack (for example, the Kramer **PIP-4**).
2. Hold both the **PIP-4** and the **RK-1** with your hands and turn them upside down.
3. Insert and the appropriate amount of screws through the holes on the **RK-1** that fit the holes on the underside of the **PIP-4**, using the M3x5 screws supplied with the unit (as illustrated in [Figure 2](#)).
4. Tighten the screws.
5. Rotate the **RK-1** horizontally with the unit connected.
6. Place the next unit (for example, the Kramer **PS-1DVI**) next to the unit that is already mounted.
7. Repeat steps 2 to 6 for each other unit.

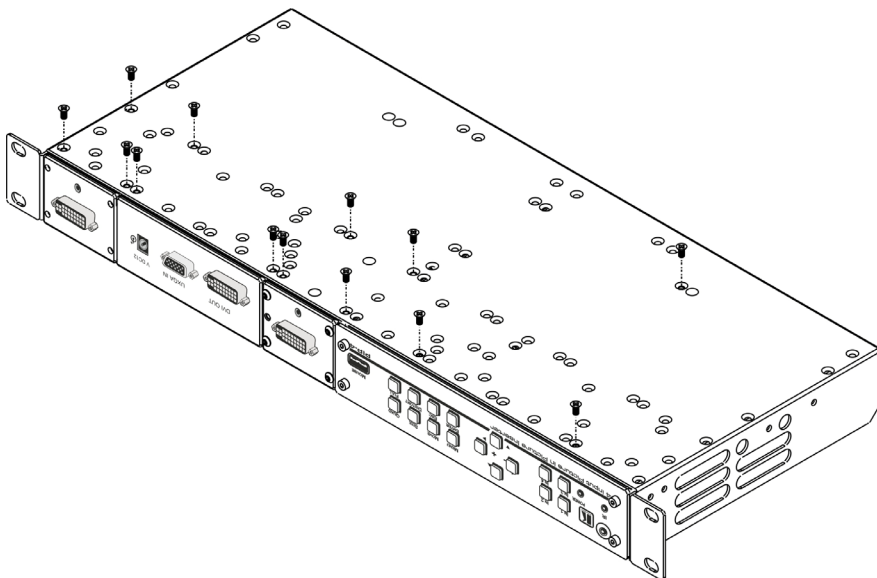

*Figure 2: RK-1 Rack Adapter – Underside*



## 5.1 Mounting Units that do not have Underside Screw Holes

Some Kramer machines do not have screw holes on the underside, which fit the holes on the **RK-1**. These machines (for example, the **VP-5xl**<sup>1</sup> or the **VA-50P**<sup>2</sup>) are connected via the screw holes on the sides of the **RK-1**.

To mount the units on the **RK-1** as illustrated in [Figure 3](#) and [Figure 4](#) (**VP-5xl** and the **VA-50P** respectively), do the following:

1. Unscrew the two M3x6 screws from the side panel of the unit (for example, the Kramer **VP-5xl** or the **VA-50P**), which will be attached to the side panel of the **RK-1**.
2. Place the unit on the rack (for example, the Kramer **VP-5xl** or the **VA-50P**), adjacent to the inner side panel of the **RK-1**.
3. Insert the two M3x6 screws through the holes on the side panel of the **RK-1** that fit the holes on the side panel of the unit (as illustrated in [Figure 3](#) and [Figure 4](#)).
4. Tighten the screws.

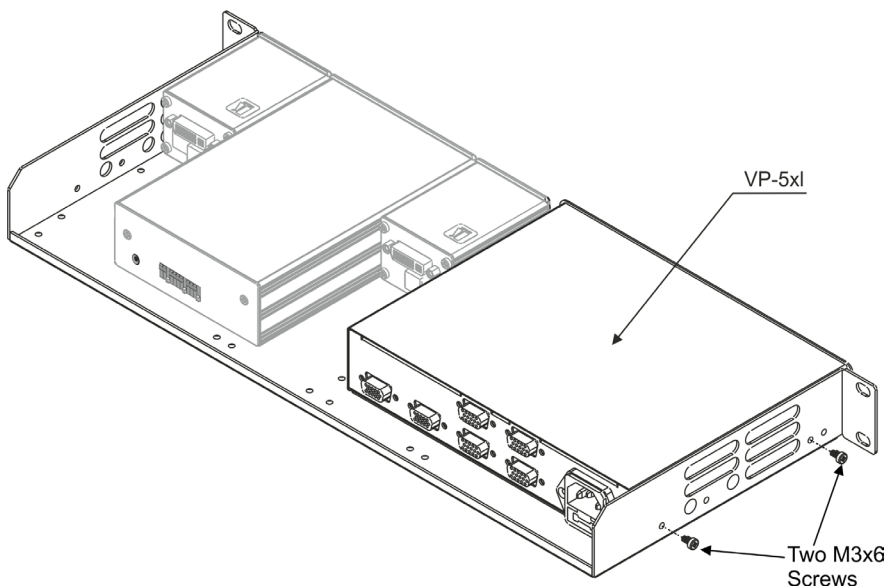

*Figure 3: Mounting a half-19" unit via Screws on the RK-1 Side Panel*

<sup>1</sup> A half-19" unit

<sup>2</sup> A 6.5" unit, see Table 2

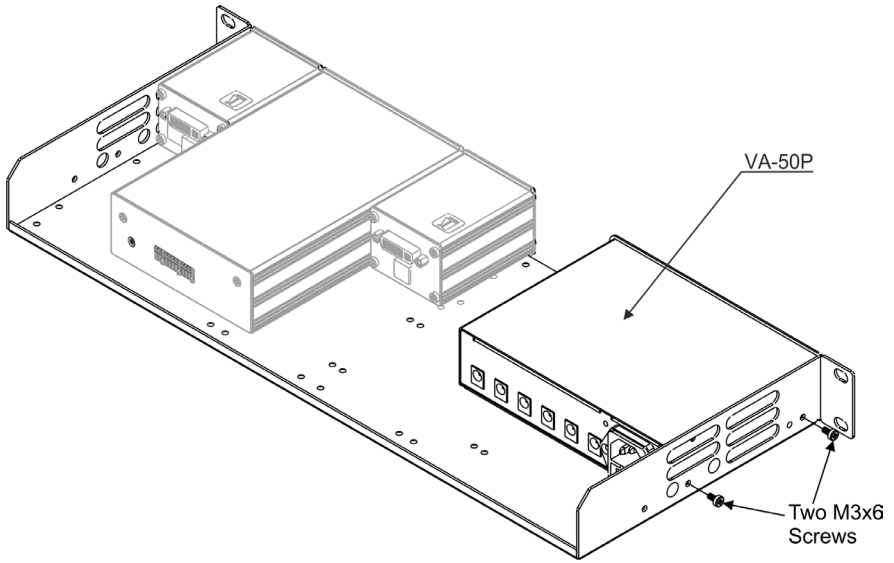

*Figure 4: Mounting a 6.5" Machine via Screws on the RK-1 Side Panel 104B (FC-31xl)*

## 5.2 Connecting a Blank Panel to the RK-1

You can connect a blank panel<sup>1</sup> to the **RK-1** to cover any empty spaces, as the example in [Figure 5](#) illustrates:

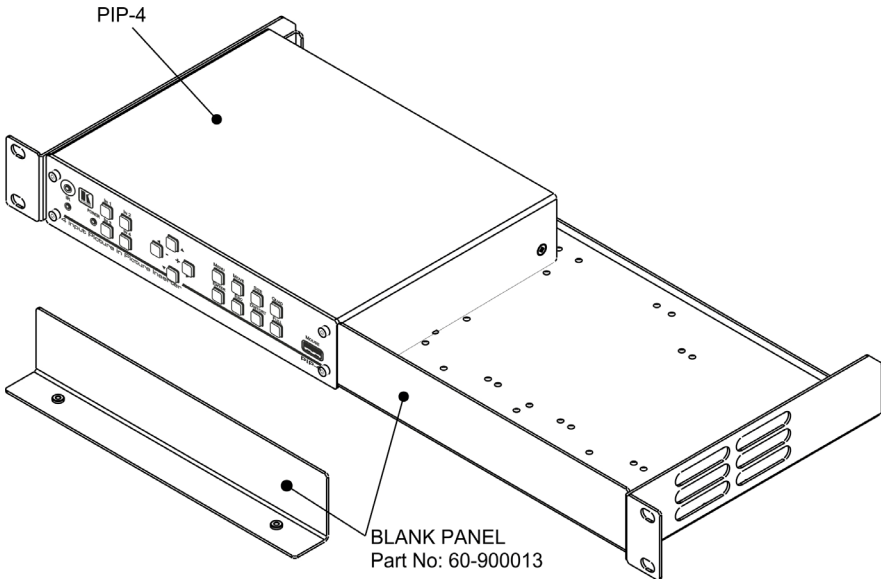

*Figure 5: RK-1 Rack Adapter – Connecting a Blank Panel*

## 6 Technical Specifications

[Table 5](#) includes the technical specifications:

*Table 5: Technical Specifications<sup>2</sup> of the RK-1*

DIMENSIONS:	19-inch (W), 7-inch (D) 1U (H)
WEIGHT:	1.2kg. (2.65lbs.) approx.
ACCESSORIES:	20 M3x5 screws, 1 half-19" 1U blank panel <sup>3</sup>
OPTIONS:	Blank panels <sup>4</sup>

<sup>1</sup> Specified in [Section 6](#)

<sup>2</sup> Specifications are subject to change without notice

<sup>3</sup> P/N: 60-900013

<sup>4</sup> See [Table 3](#)

---

## LIMITED WARRANTY

Kramer Electronics (hereafter *Kramer*) warrants this product free from defects in material and workmanship under the following terms.

### HOW LONG IS THE WARRANTY

Labor and parts are warranted for seven years from the date of the first customer purchase.

### WHO IS PROTECTED?

Only the first purchase customer may enforce this warranty.

### WHAT IS COVERED AND WHAT IS NOT COVERED

Except as below, this warranty covers all defects in material or workmanship in this product. The following are not covered by the warranty:

1. Any product which is not distributed by Kramer, or which is not purchased from an authorized Kramer dealer. If you are uncertain as to whether a dealer is authorized, please contact Kramer at one of the agents listed in the Web site [www.kramerelectronics.com](http://www.kramerelectronics.com).
2. Any product, on which the serial number has been defaced, modified or removed, or on which the WARRANTY VOID IF TAMPERED sticker has been torn, reattached, removed or otherwise interfered with.
3. Damage, deterioration or malfunction resulting from:
  - i) Accident, misuse, abuse, neglect, fire, water, lightning or other acts of nature
  - ii) Product modification, or failure to follow instructions supplied with the product
  - iii) Repair or attempted repair by anyone not authorized by Kramer
  - iv) Any shipment of the product (claims must be presented to the carrier)
  - v) Removal or installation of the product
  - vi) Any other cause, which does not relate to a product defect
  - vii) Cartons, equipment enclosures, cables or accessories used in conjunction with the product

### WHAT WE WILL PAY FOR AND WHAT WE WILL NOT PAY FOR

We will pay labor and material expenses for covered items. We will not pay for the following:

1. Removal or installations charges.
2. Costs of initial technical adjustments (set-up), including adjustment of user controls or programming. These costs are the responsibility of the Kramer dealer from whom the product was purchased.
3. Shipping charges.

### HOW YOU CAN GET WARRANTY SERVICE

1. To obtain service on you product, you must take or ship it prepaid to any authorized Kramer service center.
2. Whenever warranty service is required, the original dated invoice (or a copy) must be presented as proof of warranty coverage, and should be included in any shipment of the product. Please also include in any mailing a contact name, company, address, and a description of the problem(s).
3. For the name of the nearest Kramer authorized service center, consult your authorized dealer.

### LIMITATION OF IMPLIED WARRANTIES

All implied warranties, including warranties of merchantability and fitness for a particular purpose, are limited in duration to the length of this warranty.

### EXCLUSION OF DAMAGES

The liability of Kramer for any effective products is limited to the repair or replacement of the product at our option. Kramer shall not be liable for:

1. Damage to other property caused by defects in this product, damages based upon inconvenience, loss of use of the product, loss of time, commercial loss; or:
2. Any other damages, whether incidental, consequential or otherwise. Some countries may not allow limitations on how long an implied warranty lasts and/or do not allow the exclusion or limitation of incidental or consequential damages, so the above limitations and exclusions may not apply to you.

This warranty gives you specific legal rights, and you may also have other rights, which vary from place to place.

**NOTE:** All products returned to Kramer for service must have prior approval. This may be obtained from your dealer.

This equipment has been tested to determine compliance with the requirements of:

- EN-50081: "Electromagnetic compatibility (EMC); generic emission standard.  
Part 1: Residential, commercial and light industry"
- EN-50082: "Electromagnetic compatibility (EMC) generic immunity standard.  
Part 1: Residential, commercial and light industry environment".
- CFR-47: FCC\* Rules and Regulations:  
Part 15: "Radio frequency devices  
Subpart B Unintentional radiators"

### CAUTION!

- Servicing the machines can only be done by an authorized Kramer technician. Any user who makes changes or modifications to the unit without the expressed approval of the manufacturer will void user authority to operate the equipment.
- Use the supplied DC power supply to feed power to the machine.
- Please use recommended interconnection cables to connect the machine to other components.

\* FCC and CE approved using STP cable (for twisted pair products)



---

**For the latest information on our products and a list of Kramer distributors, visit our Web site: [www.kramerelectronics.com](http://www.kramerelectronics.com), where updates to this user manual may be found. We welcome your questions, comments and feedback.**



**Caution**

**Safety Warning:**

Disconnect the unit from the power supply before opening/servicing.



PN: 2900-000275



Rev: 4

---

**Kramer Electronics, Ltd.**

Web site: [www.kramerelectronics.com](http://www.kramerelectronics.com)

E-mail: [info@kramerel.com](mailto:info@kramerel.com)

**P/N: 2900-000275 REV 4**