



**HDBT**<sup>®</sup>  
5-Play<sup>™</sup>

**PU-507WPRX**  
5Play<sup>™</sup> HDBaseT<sup>™</sup> Wall Plate Receiver  
(inc. PoC & single LAN, up to 100m)

**OPERATION MANUAL**



## **DISCLAIMERS**

The information in this manual has been carefully checked and is believed to be accurate. CYP (UK) Ltd assumes no responsibility for any infringements of patents or other rights of third parties which may result from its use.

CYP (UK) Ltd assumes no responsibility for any inaccuracies that may be contained in this document. CYP (UK) Ltd also makes no commitment to update or to keep current the information contained in this document.

CYP (UK) Ltd reserves the right to make improvements to this document and/or product at any time and without notice.

## **COPYRIGHT NOTICE**

No part of this document may be reproduced, transmitted, transcribed, stored in a retrieval system, or any of its part translated into any language or computer file, in any form or by any means—electronic, mechanical, magnetic, optical, chemical, manual, or otherwise—without express written permission and consent from CYP (UK) Ltd.

© Copyright 2019 by CYP (UK) Ltd.

All Rights Reserved.

Version 1.1

## **TRADEMARK ACKNOWLEDGMENTS**

All products or service names mentioned in this document may be trademarks of the companies with which they are associated.

---



## SAFETY PRECAUTIONS

Please read all instructions before attempting to unpack, install or operate this equipment and before connecting the power supply.

Please keep the following in mind as you unpack and install this equipment:

- Always follow basic safety precautions to reduce the risk of fire, electrical shock and injury to persons.
- To prevent fire or shock hazard, do not expose the unit to rain, moisture or install this product near water.
- Never spill liquid of any kind on or into this product.
- Never push an object of any kind into this product through any openings or empty slots in the unit, as you may damage parts inside the unit.
- Do not attach the power supply cabling to building surfaces.
- Use only the supplied power supply unit (PSU). Do not use the PSU if it is damaged.
- Do not allow anything to rest on the power cabling or allow any weight to be placed upon it or any person walk on it.
- To protect the unit from overheating, do not block any vents or openings in the unit housing that provide ventilation and allow for sufficient space for air to circulate around the unit.

## REVISION HISTORY

VERSION NO.	DATE	SUMMARY OF CHANGE
V1.00	29/01/13	First Release
V1.01	08/10/13	Minor updates
V1.02	22/08/19	Updated Specifications

# CONTENTS

<b>1. Introduction .....</b>	<b>6</b>
<b>2. Applications .....</b>	<b>6</b>
<b>3. Package Contents .....</b>	<b>6</b>
<b>4. System Requirements .....</b>	<b>6</b>
<b>5. Features.....</b>	<b>7</b>
<b>6. Operation Controls and Functions .....</b>	<b>8</b>
6.1 Receiver Front Panel.....	8
6.2 Receiver Rear Panel.....	9
6.3 IR Cable Pin Assignment .....	9
6.4 D-Sub 9 Pin Definitions .....	10
<b>7. Connection Diagram .....</b>	<b>11</b>
Option 1: Point to Point.....	11
Option 2: Matrix System.....	12
<b>8. Specifications.....</b>	<b>13</b>
8.1 Technical Specification .....	13
8.2 Cable Specifications.....	14
<b>9. Acronyms.....</b>	<b>15</b>

---

## 1. INTRODUCTION

The flagship PU-507-RX HDBaseT™ Receiver is now available in a Wall Plate version for seamless integration into any installation. It is designed to receive uncompressed video, audio and IR control data from a compatible transmitter over a single run of CAT5e/6/7 cable at a distance of up to 100 metres at 1080p or 70 metres at 4K. It has the added benefit of control through the built-in RS-232 and IR ports and a bi-directional LAN serving connection. Additionally, it can be powered by a compatible transmitter unit via the Power over Cable (PoC) functionality allowing for greater flexibility in installations.

## 2. APPLICATIONS

- /// Household entertainment sharing and control
- /// Lecture room display and control
- /// Showroom display and control
- /// Meeting room presentation and control
- /// Classroom display and control

## 3. PACKAGE CONTENTS

- /// HDMI over Single CAT5e/CAT6 Receiver x 1
- /// IR Receiver x 1
- /// IR Transmitter x 1
- /// Operation Manual

## 4. SYSTEM REQUIREMENTS

- /// HDMI equipped source device (connected with HDMI cables) or DVI equipped source (connected with DVI to HDMI cables)
- /// HDMI equipped display (TV or monitor) or an HDMI equipped AV receiver, connected with HDMI cables
- /// Industry standard CAT5e/6/7 cable
- /// Compatible PoC HDBaseT™ Receiver.

## 5. FEATURES

- /// HDMI 1.x and DVI 1.0 compliant
- /// HDCP compliant
- /// Supports HDMI 3D and 4K x 2K features
- /// Supports HDCP repeater and CEC bypass
- /// Supports distance up to 100m/328ft at 1080p and 70m/229ft at 4K through CAT5e/6/7 cable
- /// HDMI input resolutions up to 4K@60Hz (YUV 4:2:0, 8-bit) or 4K@30Hz (YUV 4:4:4, 8-bit)
- /// Supports pass-through of audio formats including LPCM 2.0/5.1/7.1, and Bitstream over HDMI
- /// HDBaseT™ 5Play™ convergence: uncompressed high definition Video and Audio, LAN serving, Power over Cable (PoC) and RS-232/IR control
- /// Easy to install wall plate design

Note:

1. *This system was tested with CAT6/23AWG and CAT5e/24AWG cables, results may vary with cables of a different specification.*
2. *The PoC function requires a compatible Transmitter unit. Transmitters from other brands may not be compatible.*
3. *For playback of 4K2K HDMI source signals, a 4K2K capable display and High Speed HDMI cables are required.*

## 6. OPERATION CONTROLS AND FUNCTIONS

### 6.1 Receiver Front Panel

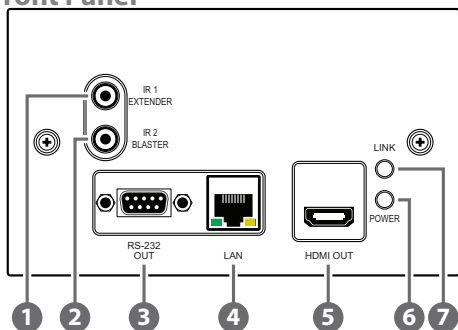

- 1 IR 1 EXTENDER:** Connect an IR Extender cable for IR signal reception. Signals received will be transmitted from any IR blaster connected to the transmitter unit. Ensure that the remote being used is within the direct line-of-sight of the IR Extender.
- 2 IR 2 BLASTER:** Connect an IR Blaster cable for IR signal transmission. IR signals received by an IR extender connected to the transmitter unit will be transmitted by this blaster. Place the IR Blaster in direct line-of-sight of the equipment to be controlled.
- 3 RS-232 OUT:** Connect to the device that is to be controlled (via D-sub 9-pin female cable) by RS-232 commands.
- 4 LAN:** Connect to an active network for LAN serving. When the transmitter or any compatible LAN equipped receivers are connected to a network, this allows the network access (including internet access if available) to be shared between the receiver and all connected receivers. Connect any Ethernet equipped device e.g. a Smart TV or games console to the LAN port of a receiver for that device to share the network/internet access.
- 5 HDMI OUT:** Connect to a HDMI equipped TV/monitor for display of the HDMI input signal.
- 6 POWER LED:** This LED will illuminate when the device is connected to a power supply or powered by another unit via PoC.
- 7 LINK LED:** This LED will illuminate when both the source connected to the transmitter and the display connected to the receiver are connected.



## 6.2 Receiver Rear Panel

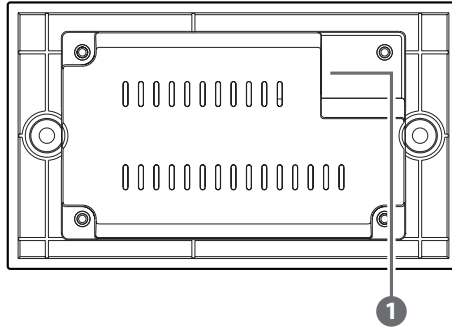

- ① **CAT5e/6/7 IN:** Connect to the transmitter unit with a single CAT5e/6/7 cable for transmission of all data signals.

## 6.3 IR Cable Pin Assignment

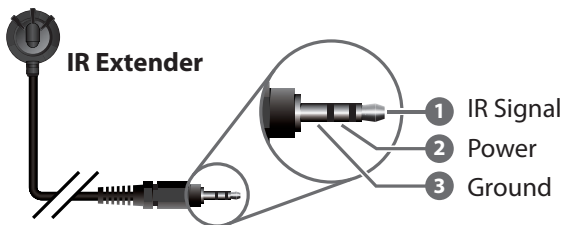
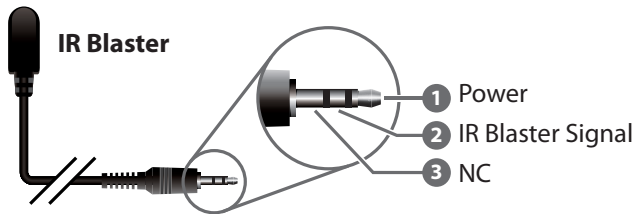

## 6.4 D-Sub 9 Pin Definitions

Pin	Define TX/RX
1	N/C
2	TxD/RxD
3	RxD/TxD
4	N/C
5	GND
6	N/C
7	N/C
8	N/C
9	N/C

# 7. CONNECTION DIAGRAM

## Option 1: Point to Point

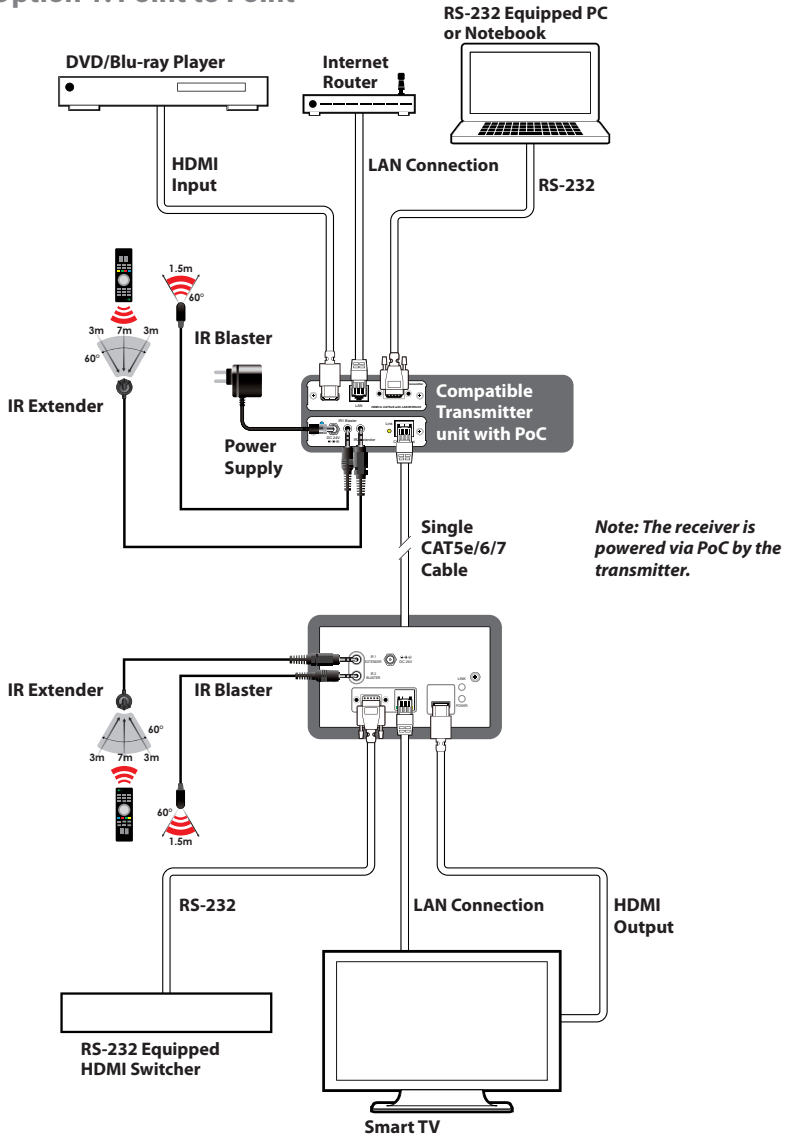

## Option 2: Matrix System

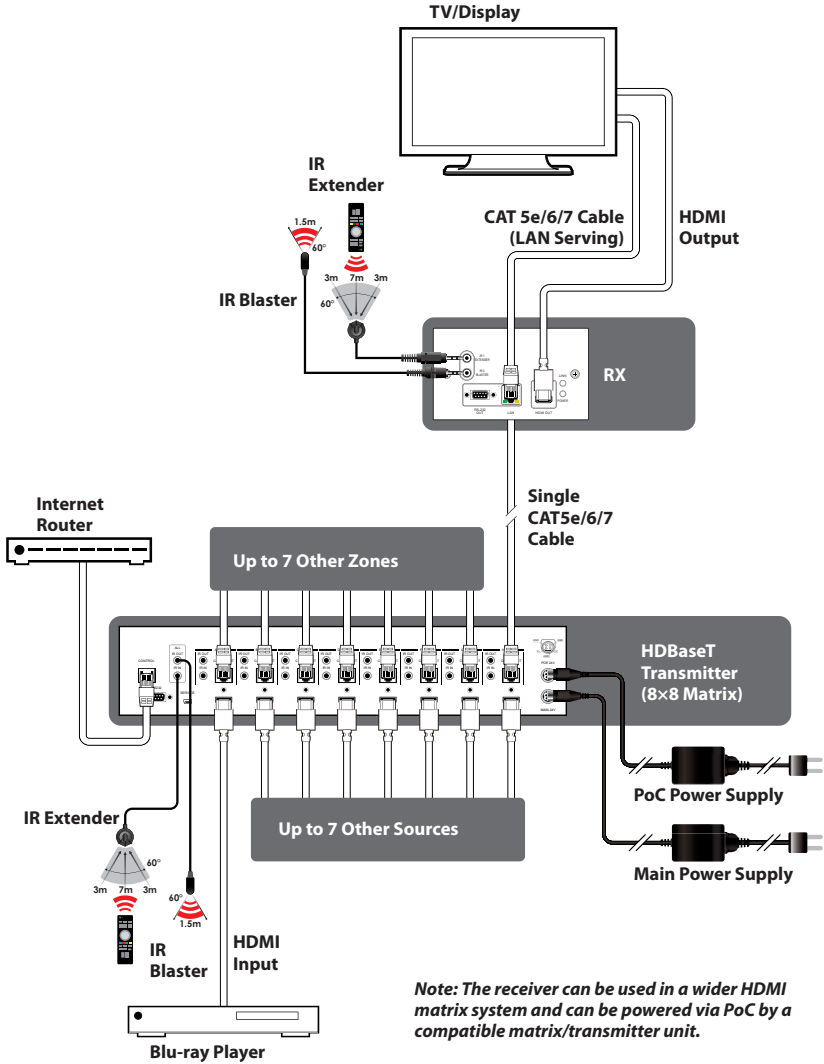

## 8. SPECIFICATIONS

### 8.1 Technical Specification

<b>Video Bandwidth</b>	340 MHz/10.2 Gbps
<b>Input Ports</b>	1×CAT5e/6/7, 1×LAN, 1×IR Extender
<b>Output Ports</b>	1×HDMI, 1×RS-232, 1×IR Blaster
<b>IR Frequency</b>	30 – 50kHz (30 – 60kHz under ideal conditions)
<b>Baud Rate</b>	Up to 115200/sec
<b>ESD Protection</b>	Human-body Model: ±8kV (air-gap discharge) ±4kV (contact discharge)
<b>Dimensions</b>	145.7 mm (W)×85.7 mm (D)×36.5 mm (H)/ Jacks Excluded 145.7 mm (W)×85.7 mm (D)×39.5 mm (H)/ Jacks Included
<b>Weight</b>	160 g
<b>Chassis Material</b>	Plastic
<b>Colour</b>	White
<b>Operating Temperature</b>	0°C~40°C/32°F~104°F
<b>Storage Temperature</b>	-20°C~60°C/-4°F~140°F
<b>Relative Humidity</b>	20~90% RH (non-condensing)
<b>Power Consumption</b>	12W (PoC), 9W (Main)

## 8.2 Cable Specifications

Cable Length	1080p		4K30	4K60
	8-bit	12-bit	(4:4:4) 8-bit	(4:2:0) 8-bit
<b>High Speed HDMI Cable</b>				
<b>HDMI Input</b>	15m	10m	5m	5m
<b>HDMI Output</b>	15m	10m	5m	5m
<b>Ethernet Cable</b>				
<b>Cat.5e/6/7</b>	100m		70m	

### 1080p (FHD Video)

- Up to 1080p@60Hz, 12-bit colour
- Data rates lower than 5.3Gbps or below 225MHz TMDS clock

### 4K30 (UHD Video)

- 4K@24/25/30Hz & 4K@50/60Hz (4:2:0), 8-bit colour
- Data rates higher than 5.3Gbps or above 225MHz TMDS clock but below 10.2Gbps

## 9. ACRONYMS

ACRONYM	COMPLETE TERM
<b>CAT5e</b>	Category 5 Cable
<b>CAT6</b>	Category 6 Cable
<b>CEC</b>	Consumer Electronics Control
<b>DVI</b>	Digital Visual Interface
<b>HDCP</b>	High-bandwidth Digital Content Protection
<b>HDMI</b>	High Definition Multimedia Interface
<b>IR</b>	Infrared



---

CYP (UK) Ltd., Unit 7, Shepperton Business Park, Govett Avenue, Shepperton,  
Middlesex, TW17 8BA

Tel: +44 (0) 20 3137 9180 | Fax: +44 (0) 20 3137 6279

Email: [sales@cypeurope.com](mailto:sales@cypeurope.com)

[www.cypeurope.com](http://www.cypeurope.com)

v1.02