

MULTIMEDIA PROJECTOR 4K600STZ User's Manual



Safety Instructions

Before Use

Basic Guide

Installation Procedure

Connection Procedure

Projection Procedure

Convenient Features

Advanced Guide

Using Menus

Menu Configuration

Menu Settings

Using the Projector on a Network

Advanced Projection

Other Information

Maintenance

Product Specifications

Troubleshooting

How to Use This Manual

Thank you for purchasing a Canon projector.

The 4K600STZ Multimedia Projector is a high-performance laser projector capable of projecting high-resolution computer screens and high-quality digital images on a large screen.

This Manual

This is the user's manual for the 4K600STZ Multimedia Projector (hereafter, "projector"). The "Basic Guide" section describes installation and basic use of the projector. Descriptions of menus and how to connect the projector to a network are given in the "Advanced Guide" section. Read this manual thoroughly to make the most of your projector. Installation of the projector should be performed by a qualified technician, if possible. Contact the Canon Customer Support Center for further information.

Symbols of Button Operations

The projector can be operated using the buttons on the remote control or on the side of the projector.

In this document, the button's operations are shown as below.

Operation of buttons on side of projector

Remote control button operation

Indicate the buttons to be pressed

■ When the Language Selection Screen Appears

A screen appears when the projector is turned on for the first time. You can select a language to be used by the projector for displaying menus and messages in the window. Select the desired language with the pointer buttons and press the OK button.

You can change the language from the menu at a later time. (P126)

If the language selection screen is out of focus, adjust the focus. (P59)



An item highlighted in orange will be selected.

Symbols Used in This Manual

Sections labeled with these symbols give the following kinds of information.

 Indicates precautions and information to note when using the projector.

Table of Contents

| | | | |
|--|-----------|--|------------|
| How to Use This Manual | 2 | Advanced Guide | 75 |
| Projector Highlights | 4 | Using Menus | 76 |
| Safety Instructions | 6 | Menu Configuration | 76 |
| Safety Symbols in this Manual | 12 | Basic Menu Operations | 77 |
| Precautions for Use | 13 | Menu Configuration | 80 |
| Installation and Handling | | Menu Settings | 92 |
| Precautions | 14 | Input settings | 92 |
| Laser Precautions | 16 | Image adjustment | 97 |
| Precautions for the Batteries of the | | Install settings..... | 106 |
| Remote Control | 18 | System settings | 117 |
| For Safe Use | 20 | Network settings | 135 |
| Before Installation | 21 | Wireless LAN (Wi-Fi)..... | 138 |
| Precautions When Carrying/Shipping | | Completing Projector Settings | 140 |
| the Projector..... | 21 | Checking Projector Information | 155 |
| Precautions for Installation..... | 21 | Using the Projector on a | |
| Open Source Software | 26 | Network | 156 |
| Before Use | 27 | Completing Computer Settings for a | |
| Included Accessories | 27 | Network Connection | 156 |
| Part Names | 28 | Setting Up the Network | 160 |
| Preparing the Remote Control..... | 35 | Controlling the Projector from a | |
| Basic Guide | 37 | Computer | 181 |
| Installation Procedure | 38 | Advanced Projection | 183 |
| Setting Up the Projector | 38 | Projecting from Multiple Projectors at | |
| Relationship between Image Size and | | Once (Edge Blending) | 183 |
| Projecting Distance | 40 | Advanced Registration to Adjust | |
| Lens Shift Function | 42 | Projected Images | 187 |
| Connection Procedure | 44 | Adjusting Peripheral Focus | 191 |
| Connecting a Computer | 44 | Other Information | 193 |
| Connecting AV Equipment..... | 45 | Maintenance | 194 |
| 4K Projection..... | 46 | Cleaning the Projector..... | 194 |
| Plugging the Projector In | 51 | Replacing the Air Filter..... | 194 |
| Projection Procedure | 52 | Product Specifications | 197 |
| Step 1 Turn the Projector On | 52 | Displayed Test Patterns | 197 |
| Step 2 Select an Input Signal..... | 55 | Supported Signal Types | 198 |
| Step 3 Adjust the Image | 57 | Specifications..... | 202 |
| Step 4 Select an Aspect Ratio (Screen | | Troubleshooting | 208 |
| Aspect) Matching the Screen..... | 64 | LED Indicator Details | 208 |
| Step 5 Adjusting Keystone | | Symptoms and Solutions | 209 |
| Distortion | 65 | Index | 214 |
| Step 6 Select the Image Quality (Image | | Option | 216 |
| Mode) | 68 | | |
| Step 7 Turn the Projector Off..... | 71 | | |
| Convenient Features | 72 | | |

Projector Highlights

4K Model With a High-Definition, 4096 x 2400 LCOS Panel

Outstanding projection resolution of up to 4096 x 2400 is possible, using three 0.76 inch liquid crystal on silicon (LCOS) panels in conjunction with dual high-performance image processors and a new 4K-compatible wide zoom lens.

Bright Yet Compact, With a Laser Light Source

A bright (6,000 lumen) 4K projector that is also compact, at 559 x 624 x 201 mm (22.0 x 24.6 x 7.9 in., W x D x H). Features a laser light source that lasts longer than traditional mercury lamps. (P202)

Supports Fully Digital Input

Compatible with HDMI: 2 (4K / Deep Color / HDCP2.2), the projector enables 4K projection (up to 4096 x 2160 at 60 Hz) via a single HDMI cable when connected to equipment such as a Blu-ray player/recorder. 4K projection from multiple input terminals — two for HDMI and four for DVI — is also supported, using a multi-input feature. (P47)

Peripheral Focus Adjustment

Image focus can be adjusted on the edges of the screen, enabling use in dome projection. (P112, P191)

Edge Blending

Blend the overlapping edges of images from multiple projectors to make the overall image more seamless. (P112)

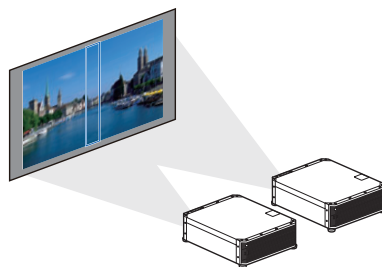

High-Precision Image Registration

Precise correction of red, green, or blue misalignment in different areas of the screen is possible by color and area. (P110)

Superior Video Viewing Experience

Refinements in motion blur reduction make video projection more enjoyable to watch. (P125)

Fixed Brightness Feature

When the projector is used for a long time, its brightness gradually declines. This feature pre-sets the brightness of the first use to a lower level, and then automatically adjusts the output of the light source so that the same brightness level is maintained. (P111)

Expanded Dynamic Range

Ready for High Dynamic Range (HDR) content, the projector offers an expanded range of image luminance to preserve detail in highlights and shadows. (P96)

Scheduling

Automate projector tasks according to your schedules. Turn the projector on or off, switch input signals, and more. (P129)

Wi-Fi Connectivity

In addition to wired LAN connectivity, the projector also supports Wi-Fi. In Projector Access Point (PJ AP) mode, the projector can be connected to up to five computers without using a wireless access point.

Quiet Mode

This feature reduces laser output from the light source to less than half and lowers the speed of the cooling fan to reduce noise. (P104)





Safety Instructions

Before installing and operating the projector, read this manual thoroughly.

This projector provides many convenient features and functions. Operating the projector properly enables you to manage those features and maintain it in good condition for many years to come.

Improper operation may result in not only shortening the product life, but also malfunctions, fire hazards, or other accidents.

If your projector does not seem to be operating properly, read this manual again, check operations and cable connections, and try the solutions in the “Troubleshooting” section in the back of this manual. If the problem still persists, contact the Canon Customer Support Center.

| | | |
|---|--|---|
|  | <p>CAUTION</p> <p>RISK OF ELECTRIC SHOCK</p> <p>DO NOT OPEN</p> |  |
|  | THIS SYMBOL INDICATES THAT DANGEROUS VOLTAGE CONSTITUTING A RISK OF ELECTRIC SHOCK IS PRESENT WITHIN THIS UNIT. | |
|  | THIS SYMBOL INDICATES THAT THERE ARE IMPORTANT OPERATING AND MAINTENANCE INSTRUCTIONS FOR THIS UNIT IN THE OWNER'S MANUAL. | |

CAUTION

Not for use in a computer room as defined in the Standard for the Protection of Electronic Computer / Data Processing Equipment, ANSI / NFPA 75.

Safety Precautions

WARNING:

- **THIS APPARATUS MUST BE GROUNDED.**
- **TO REDUCE THE RISK OF FIRE OR ELECTRIC SHOCK, DO NOT EXPOSE THIS APPLIANCE TO RAIN OR MOISTURE.**
- This projector produces intense light from the projection lens. Do not stare directly into the lens, otherwise eye damage could result. Be especially careful that children do not stare directly into the beam.
- Install the projector in a proper position. Otherwise it may result in a fire hazard.
- Allowing the proper amount of space on the top, sides, and rear of the projector cabinet is critical for proper air circulation and cooling of the unit. The diagrams shown here indicates the minimum space required. If the projector is to be built into a compartment or similarly enclosed, these minimum distances must be maintained.

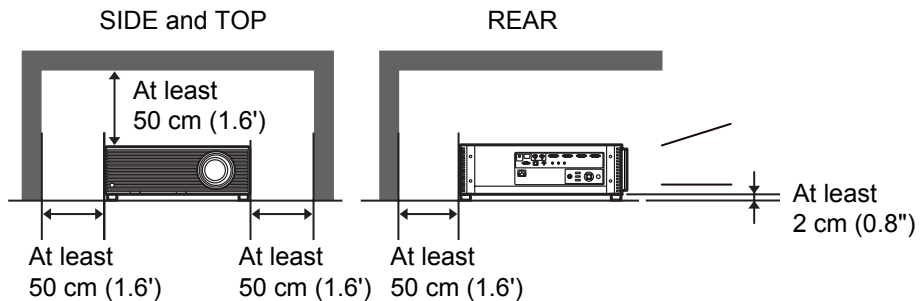

- Do not cover the ventilation slots on the projector. Heat build-up can reduce the service life of your projector, and can also be dangerous.
- If the projector is unused for an extended time, unplug the projector from the power outlet.
- Do not project the same image for a long time.

An afterimage may remain on the LCD panels due to the characteristics of the panels of the projector.

CAUTION ON HANGING FROM THE CEILING

When hanging the projector from the ceiling, clean the air intake vents and top of the projector periodically with a vacuum cleaner. If you leave the projector unclean for a long time, the cooling fans can be clogged with dust, and it may cause a breakdown or a disaster.

DO NOT SET THE PROJECTOR IN GREASY, WET, OR SMOKY CONDITIONS SUCH AS IN A KITCHEN TO PREVENT A BREAKDOWN OR A DISASTER. IF THE PROJECTOR COMES IN CONTACT WITH OIL OR CHEMICALS, IT MAY BECOME DETERIORATED.

■ READ AND KEEP THIS OWNER'S MANUAL FOR LATER USE.

All the safety and operating instructions should be read before beginning to operate the product.

Read all of the instructions given here and retain them for later use. Unplug this projector from the AC power supply before cleaning. Do not use liquid or aerosol cleaners on the projector. Use a damp cloth for cleaning.

Follow all warnings and instructions marked on the projector.

For added protection of the projector during a lightning storm, or when it is left unattended or unused for long periods of time, unplug it from the wall outlet. This will prevent damage due to lightning and power surges.

Do not expose this unit to rain or use near water... for example, in a wet basement, near a swimming pool, etc...

Do not use attachments not recommended by the manufacturer as they may result in hazards.

Do not place this projector on an unstable cart, stand, or table. The projector may fall, causing serious injury to a child or adult, and serious damage to the projector. Use only with a cart or stand recommended by the manufacturer, or sold with the projector. Wall or shelf mounting should be carried out in accordance with the manufacturer's directions, and should use a mounting kit approved by the manufacturers.

An appliance and cart combination should be moved with care. Sudden stops, excessive force, and uneven surfaces may cause the appliance and cart combination to overturn.



Slots and openings in the rear and front of the cabinet are provided for ventilation, to insure reliable operation of the equipment and to protect it from overheating.

The openings should never be covered with cloth or other materials, and the bottom opening should not be blocked by placing the projector on a bed, sofa, rug, or other similar surface. This projector should never be placed near or over a radiator or heat register.

This projector should not be placed in a built-in installation such as a book case unless proper ventilation is provided.

Never push objects of any kind into this projector through cabinet slots as they may touch dangerous voltage points or short out parts that could result in a fire or electric shock. Never spill liquid of any kind onto the projector.

Do not install the projector near the ventilation duct of air-conditioning equipment.

This projector should be operated using only the type of power source indicated on the marking label. If you are not sure of the type of power supplied, contact the Canon Customer Support Center or local power company.

Do not overload wall outlets and extension cords as this can result in fire or electric shock. Do not allow anything to rest on the power cord. Do not locate this projector where the cord may be damaged by people walking on it.

Do not attempt to service this projector yourself as opening or removing covers may expose you to dangerous voltages or other hazards. Refer all servicing to qualified service personnel.

Unplug this projector from the wall outlet and refer servicing to qualified service personnel under the following conditions:

- a. When the power cord or plug is damaged or frayed.
- b. If liquid has been spilled into the projector.
- c. If the projector has been exposed to rain or water.
- d. If the projector does not operate normally after following the operating instructions. Adjust only those controls that are covered in the operating instructions as improper adjustment of other controls may result in damage and will often require extensive work by a qualified technician to restore the projector to normal operating condition.
- e. If the projector has been dropped or the cabinet has been damaged.
- f. When the projector exhibits a distinct change in performance-this indicates a need for servicing.

When replacement parts are required, be sure the service technician uses replacement parts specified by the manufacturer that have the same characteristics as the original parts. Unauthorized substitutions may result in fire, electric shock, or injury.

Upon completion of any service or repairs to this projector, ask the service technician to perform routine safety checks to determine that the projector is in safe operating condition.

AC Power Cord Requirement

The AC Power Cord supplied with this projector meets the requirements for use in the country you purchased it.

AC Power Cord for the United States and Canada:

The AC Power Cord used in the United States and Canada is listed by the Underwriters Laboratories (UL) and certified by the Canadian Standard Association (CSA).

The AC Power Cord has a grounding-type AC line plug. This is a safety feature to ensure the plug fits into the power outlet. Do not try to tamper with this safety feature. Should you be unable to insert the plug into the outlet, contact your electrician.

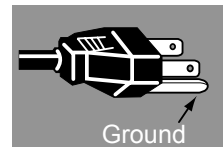

THE SOCKET-OUTLET SHOULD BE INSTALLED NEAR THE EQUIPMENT AND EASILY ACCESSIBLE.



Only for European Union and EEA (Norway, Iceland and Liechtenstein)

These symbols indicate that this product is not to be disposed of with your household waste, according to the WEEE Directive (2012/19/EU), the Battery Directive (2006/66/EC) and/or national legislation implementing those Directives.



If a chemical symbol is printed beneath the symbol shown above, in accordance with the Battery Directive, this indicates that a heavy metal (Hg = Mercury, Cd = Cadmium, Pb = Lead) is present in this battery or accumulator at a concentration above an applicable threshold specified in the Battery Directive.



This product should be handed over to a designated collection point, e.g., on an authorized one-for-one basis when you buy a new similar product or to an authorized collection site for recycling waste electrical and electronic equipment (EEE) and batteries and accumulators. Improper handling of this type of waste could have a possible impact on the environment and human health due to potentially hazardous substances that are generally associated with EEE. Your cooperation in the correct disposal of this product will contribute to the effective usage of natural resources.

For more information about the recycling of this product, please contact your local city office, waste authority, approved scheme or your household waste disposal service or visit www.canon-europe.com/weee, or www.canon-europe.com/battery.

Federal Communication Commission Notice

This device complies with Part 15 of the FCC Rules. Operation is subject to the following two conditions:

1. This device may not cause harmful interference, and
2. This device must accept any interference received, including interference that may cause undesired operation.

Note: This equipment has been tested and found to comply with the limits for a Class A digital device, pursuant to Part 15 of the FCC Rules. These limits are designed to provide reasonable protection against harmful interference when the equipment is operated in a commercial environment. This equipment generates, uses, and can radiate radio frequency energy and, if not installed and used in accordance with the instruction manual, may cause harmful interference to radio communications. Operation of this equipment in a residential area is likely to cause harmful interference in which case the user will be required to correct the interference at his own expense. The cable with a ferrite core provided with the projector must be used with this equipment in order to comply with Class A of the FCC Rules. Use of a shielded cable is required to comply with Class A of FCC Rules. Do not make any changes or modifications to the equipment unless otherwise specified in the instructions. If such changes or modifications should be made, you could be required to stop operation of the equipment.







Warning:

This is a class A product. In a domestic environment this product may cause radio interference in which case the user may be required to take adequate measures. The cable with a ferrite core provided with the projector must be used with this equipment in order to comply with Class A .

Use of a shielded cable is required to comply with Class A .

Safety Symbols in this Manual

This section describes the safety symbols used in this manual. Important projector safety information is identified by the following symbols. Always observe the safety information by these symbols.

| | |
|--|---|
|  Warning | Denotes the risk of death or serious injury from improper handling if the information is not observed. To ensure safe use, always observe this information. |
|  Caution | Denotes the risk of injury from improper handling if the information is not observed. To ensure safe use, always observe this information. |
|  | Denotes the risk of electric shock from improper handling if the information is not observed. To ensure safe use, always observe this information. |
|  | Denotes the risk of burns from improper handling if the information is not observed. To ensure safe use, always observe this information. |
|  | Denotes the risk of eye injury from laser emission if usage restrictions are not observed. |
|  Prohibition | Denotes prohibited actions. |
|  Caution | Denotes required actions or information that must be observed. |

Precautions for Use

As this section contains important safety-related information, be sure to read the following carefully beforehand in order to use your projector correctly and safely.

Warning

During installation, keep the projector plug easily accessible so that the projector can be unplugged immediately if necessary, or keep a circuit breaker within reach.

If the following situations occur, turn the power off, remove the power plug from the power outlet and contact the Canon Customer Support Center. Failure to do so could cause a fire or result in an electric shock.



- If smoke is emitted
- If an unusual smell or noise is emitted
- If water or other liquid has entered the projector
- If metal or any other foreign material has entered the projector
- If the projector is knocked over or dropped and the cabinet is damaged

Pay attention to the following points for handling the power cord. Failure to do so may cause a fire or electric shock.



Prohibition



- Do not place any objects on the power cord and do not allow it to become trapped under the projector.
- Do not cover the power cord with a carpet.
- Do not modify or excessively bend, twist, pull, wind, or bundle the power cord.
- Keep the power cord away from heaters and other sources of heat.
- Do not use a damaged power cord. If the power cord is damaged, purchase a replacement from your dealer.
- The power cord included with this projector is for use exclusively with this product. Do not use this cord for other products.

Warning

Pay attention to the following points regarding the power source, power plug and handling of the connector. Failure to do so may cause a fire or electric shock.



Prohibition



- Do not use any power source with a voltage other than the voltage indicated (AC 100–240 V).
- Do not pull the power cord and be sure to hold the power plug or connector when removing. Incorrect handling may damage the power cord.
- Do not insert any metal objects into the contact parts of the power plug or connector.



- Do not remove the power plug or connector with wet hands.



Caution



- Insert the power plug and connector securely up to the base. Additionally, do not use a damaged power plug or an outlet that is loose.
- Before using an extension cord, check carefully to avoid exceeding the cord's rated capacity.



Caution

- Periodically inspect the power plug and outlet and remove any dust or dirt from between the plug and the outlet.

Installation and Handling Precautions

Pay attention to the following points regarding installation and handling of the projector. Failure to do so may cause a fire, electric shock or personal injury.



- Do not use the projector where it might get wet, such as outdoors or by bathtubs or showers.
- Do not place containers containing a liquid on top of the projector.



- Do not touch the projector itself, the power cord, or the cable if lightning strikes.



- Do not move the projector until you have switched off the power, removed the power plug from the power outlet and unplugged any other cables.
- Unplug the projector before cleaning or maintenance.

Warning

Pay attention to the following points regarding installation and handling of the projector. Failure to do so may cause a fire, electric shock or personal injury.



Prohibition

- Do not remove the cabinet from the projector or disassemble it. The interior of the projector contains high-voltage components as well as parts that are hot. If inspection, maintenance or repair is required, contact the Canon Customer Support Center.
- Do not disassemble or modify the projector (including consumable parts) or the remote control.
- Do not look directly into the exhaust vents during use.
- Do not insert any object into vents in the projector, such as the air intake vent or exhaust vents.
- Do not place a pressurized can in front of the exhaust vents. The pressure of the contents of the can may increase due to heat from the exhaust vents and this could result in an explosion.
- When cleaning off dust or dirt from projector parts such as the lens or filter, never use any spray that is flammable. Internal parts that become hot may ignite and cause a fire.
- As strong light beams are emitted while the projector is in use, do not look directly into the projector lens. Doing so could cause an eye injury. Pay particular attention to prevent small children from doing so.



Prohibition

- Light from the projector is classified as Risk Group 2 (RG2) according to IEC 62471-5:2015.
- If children may approach the projector or touch it, always ensure the projector is used under adult supervision.
- Do not hold or install optical instruments (such as magnifying glasses, reflectors, or glasses) in the path of light from the projector. If projected light is refracted or reflected and enters people's eyes, it may result in eye injury.
- Do not lift the projector alone. Have at least one assistant.
- Do not use the projector on a soft surface such as carpet or sponge mat, etc. Doing so could cause heat to build up inside the projector and this could result in a fire.
- When setting the projector on a high surface for projection, be sure the surface is flat and stable.
- For ceiling mounting precautions, refer to the installation manual included with the ceiling mount (sold separately).



! Warning

Laser Precautions



- The projector is designated as a Class 1 laser product according to IEC/ EN 60825-1:2014.
- The equipment is designated as a Class 3R laser product according to IEC/ EN 60825-1:2007.
- Complies with FDA performance standards for laser products except for deviations pursuant to Laser Notice No. 50, dated June 24, 2007.
- Laser parameters
 - Wavelength: 450 nm – 460 nm
 - Maximum power: 144 W
 - Beam divergence: 2°



Prohibition

- The projector incorporates a laser module. Disassembly or modification is dangerous and must not be attempted.
- Operate and adjust the projector only as described in this manual. Incorrect operation or adjustment poses a risk of exposure to potentially hazardous laser light.
- If children may approach the projector or touch it, always ensure the projector is used under adult supervision.



- Do not use when damaged. Even if the projector is used as described in this manual, failure to discontinue use when it is damaged (as indicated by screen abnormalities) may result in fire, electric shock, or eye injury from laser light.



Caution

- The Laser module is equipped in this product. Use of controls or adjustments or performance of procedures other than those specified herein may result in hazardous radiation exposure.
- For assistance when disposing of the projector, contact the Canon Customer Support Center. Do not disassemble the projector yourself when disposing of it.

Explanatory and warning labels are located in the following positions on the projector.

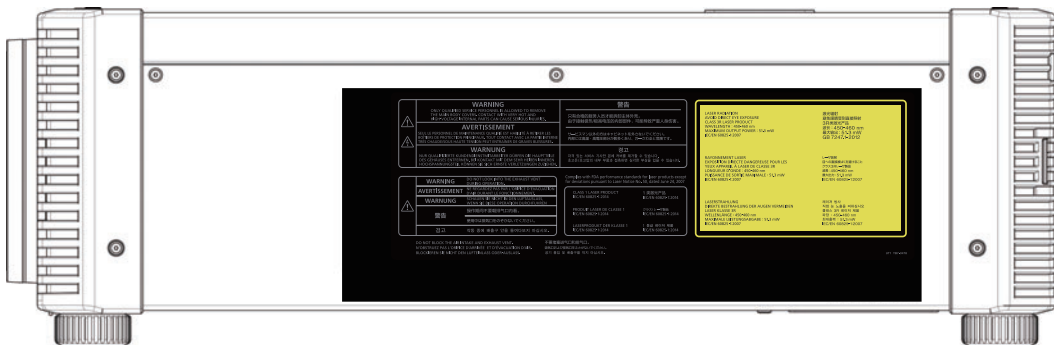

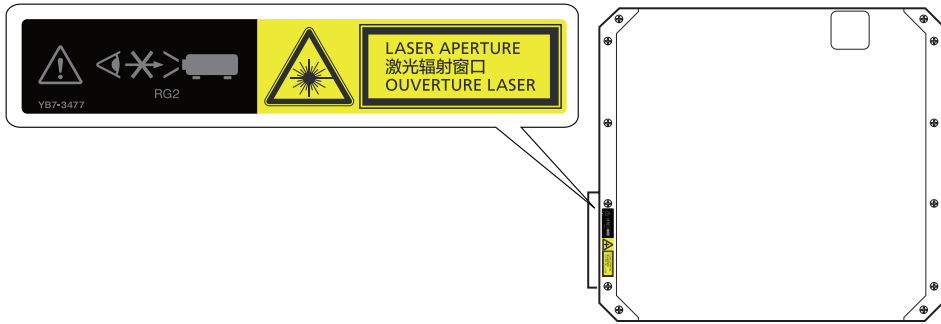

| | | | | | | | | |
|--|--|--|--|--------------------------------|--|-----------------------------------|--|------------------------------------|
| | <p>WARNING ONLY QUALIFIED SERVICE PERSONNEL IS ALLOWED TO REMOVE THE MAIN BODY COVERS. CONTACT WITH VERY HOT AND HIGH-VOLTAGE INTERNAL PARTS CAN CAUSE SERIOUS INJURIES.</p> | <p>警告 只有合格的服务人员才能拆卸主体外壳。由于接触极热/极高压的内部部件，可能导致严重人身伤害。</p> | | | | | | |
| | <p>AVERTISSEMENT SEUL LE PERSONNEL DE MAINTENANCE QUALIFIÉ EST HABILITÉ À RETIRER LES BOITIERS DE PROTECTION PRINCIPAUX. TOUT CONTACT AVEC LA PARTIE INTERNE TRÈS CHAUDE/SOUS HAUTE TENSION PEUT ENTRAÎNER DE GRAVES BLESSURES.</p> | <p>サービスマン以外の方はキャビネットを外さないでください。内部には高温・高電圧部分が多くあり、万一さわると危険です。</p> | | | | | | |
| | <p>AVERTISSEMENT NUR QUALIFIZIERTE KUNDENDIENSTMITARBEITER DÜRFEN DIE HAUPTTEILE DES GEHÄUSES ENTFERNEN. BEI KONTAKT MIT DEM SEHR HEIßEN INNEREN HOCHSPANNUNGSTEIL KÖNNEN SIE SICH ERNSTE VERLETZUNGEN ZUZIEHEN.</p> | <p>경고 저절 있는 서비스 기사만 본체 커버를 제거할 수 있습니다. 초고온/초고압의 내부 부품과 접촉하면 심각한 부상을 입을 수 있습니다.</p> | | | | | | |
| | <p>WARNING DO NOT LOOK INTO THE EXHAUST VENT DURING OPERATION.</p> | <p>Complies with FDA performance standards for Laser products except for deviations pursuant to Laser Notice No. 50, dated June 24, 2007</p> <table border="1"> <tr> <td>CLASS 1 LASER PRODUCT IEC/EN 60825-1:2014</td> <td>1 类激光产品 IEC/EN 60825-1:2014</td> </tr> <tr> <td>PRODUIT LASER DE CLASSE 1 IEC/EN 60825-1:2014</td> <td>クラス1レーザー製品 IEC/EN 60825-1:2014</td> </tr> <tr> <td>LASERPRODUKT DER KLASSE 1 IEC/EN 60825-1:2014</td> <td>1 등급 레이저 제품 IEC/EN 60825-1:2014</td> </tr> </table> | CLASS 1 LASER PRODUCT IEC/EN 60825-1:2014 | 1 类激光产品 IEC/EN 60825-1:2014 | PRODUIT LASER DE CLASSE 1 IEC/EN 60825-1:2014 | クラス1レーザー製品 IEC/EN 60825-1:2014 | LASERPRODUKT DER KLASSE 1 IEC/EN 60825-1:2014 | 1 등급 레이저 제품 IEC/EN 60825-1:2014 |
| | CLASS 1 LASER PRODUCT IEC/EN 60825-1:2014 | | 1 类激光产品 IEC/EN 60825-1:2014 | | | | | |
| | PRODUIT LASER DE CLASSE 1 IEC/EN 60825-1:2014 | | クラス1レーザー製品 IEC/EN 60825-1:2014 | | | | | |
| | LASERPRODUKT DER KLASSE 1 IEC/EN 60825-1:2014 | | 1 등급 레이저 제품 IEC/EN 60825-1:2014 | | | | | |
| <p>AVERTISSEMENT NE REGARDEZ PAS PAR L'ORIFICE D'ÉVACUATION D'AIR DURANT LE FONCTIONNEMENT.</p> | | | | | | | | |
| <p>WARNUNG SCHAUEN SIE NICHT IN DEN LUFTAUSSLASS, WENN SIE DIESE OPERATION DURCHFÜHREN</p> | | | | | | | | |
| <p>警告 操作期间不要朝排气口内看。 使用中は排気口をのぞかないでください。</p> | | | | | | | | |
| <p>경고 작동 중에 배출구 안을 들여다보지 마십시오.</p> | | | | | | | | |
| <p>DO NOT BLOCK THE AIR INTAKE AND EXHAUST VENT. N'OBSTRUEZ PAS L'ORIFICE D'ARRIVÉE ET D'ÉVACUATION D'AIR. BLOCKIEREN SIE NICHT DEN LUFTENLASS ODER-AUSLASS.</p> | <p>不要堵塞进气口和排气口。 吸気口および排気口をふさがしないでください。 공기 흡입 및 배출구를 막지 마십시오.</p> | | | | | | | |

| | |
|--|---|
| <p>LASER RADIATION AVOID DIRECT EYE EXPOSURE CLASS 3R LASER PRODUCT WAVELENGTH : 450-460 nm MAXIMUM OUTPUT POWER : 51.3 mW IEC/EN 60825-1:2007</p> | <p>激光辐射 避免眼睛受到直接照射 3R类激光产品 波长：450-460 nm 最大输出：51.3 mW GB 7247.1-2012</p> |
| <p>RAYONNEMENT LASER EXPOSITION DIRECTE DANGEREUSE POUR LES YEUX APPAREIL À LASER DE CLASSE 3R LONGUEUR D'ONDE : 450-460 nm PUISSANCE DE SORTIE MAXIMALE : 51.3 mW IEC/EN 60825-1:2007</p> | <p>레이저 방사 目への直接被ばくを避けること クラス3Rレーザー製品 波長：450-460 nm 最大出力：51.3 mW IEC/EN 60825-1:2007</p> |
| <p>LASERSTRAHLUNG DIREKTE BESTRAHLUNG DER AUGEN VERMEIDEN LASER KLASSE 3R WELLENLÄNGE : 450-460 nm MAXIMALE LEISTUNGSABGABE : 51.3 mW IEC/EN 60825-1:2007</p> | <p>레이저 방사 직접 눈 노출을 피하십시오 클래스 3R 레이저 제품 파장 : 450-460 nm 최대출력 : 51.3 mW IEC/EN 60825-1:2007</p> |

UT1 YB7-3478

Warning

Precautions for the Batteries of the Remote Control

Pay attention to the following points regarding handling of batteries. Failing to do so could result in a fire or personal injury.



Prohibition

- Do not heat, short circuit or disassemble the batteries, or place them in a fire.
- Do not attempt to recharge the batteries that are included with the remote control.



Caution

- Remove the batteries when they are flat or when the remote control will not be used for a long period of time.
- When replacing the batteries, replace both at the same time. Also, do not use two batteries of a different type at the same time.
- Insert the batteries with the + and - terminals in the correct directions.
- If any liquid from inside the batteries leaks out and contacts your skin, be sure to wash the liquid off thoroughly.

Caution

Pay attention to the following points regarding installation and handling of the projector.



- If the projector will not be used for a long period of time, be sure to remove the power plug from the power outlet to ensure safety. Failure to do so presents a risk of fire if dust accumulates on the plug or outlet.
- Parts of the cabinet around and above the exhaust vents may become hot during projection. Touching these areas during operation could cause burns to the hands. Pay particular attention in preventing young children from touching these parts. Additionally, do not place any metal objects around or above the exhaust vents. Due to the heat from the projector, doing so could cause an accident or personal injury.
- Do not place the projector where it may be exposed to oily smoke or steam, such as near kitchen counters or humidifiers. Doing so may cause fire or electric shock.
- Do not place any heavy objects on top of the projector or sit / stand on it. Pay particular attention to prevent small children from doing so. The projector may be knocked over and this could result in damage or a personal injury.
- Do not place the projector on an unstable or slanted surface. Doing so may cause the projector to fall or be knocked over and could result in a personal injury.
- Do not place any objects in front of the lens during projection. Also, do not start projection with the lens cap on. Doing so could cause a fire.
- The lens is moved by a motor up, down, left, and right in response to the lens shift function. Do not touch the lens when it is moving. There is the risk of injury.



Caution

Pay attention to the following points when carrying or transporting the projector.



Caution

- This projector is a precision instrument. Do not knock it over or subject it to impacts.
- Protection of the projector cannot be guaranteed if used packaging or shock-absorbent materials are reused. Fragments from shock-absorbent material may also enter the interior of the projector which could cause a malfunction.
- Disconnect the cables connected to the projector. Carrying the projector while the cables are attached may cause an accident.
- Retract the adjustable feet before moving the projector. Leaving the feet extended may cause damage.
- Do not touch the lens with bare hands. Any smudges or fingerprints on the lens may affect image quality.

Pay attention to the following points when installing or using the projector.



Caution

- Be careful of condensation.
If the projector is abruptly taken to a warmer location, or if the room temperature rises abruptly, moisture in the air may condense on the lens and mirror, causing the image to become blurred.
- Do not install the projector in a location where the temperature is high or low. Doing so may cause a malfunction. The temperature range for operation and storage are as follows.
Operating temperature: 0°C to 45°C (32°F to 113°F)
Humidity: up to 85%
Storage temperature: -20°C to 60°C (-4°F to 140°F)
- When using the projector at an altitude of 2,300 m (7,548') or higher:
From the projector menu, set [High altitude] to [On]. (P111)
- Do not install the projector near high-voltage electrical power lines or an electrical power source.
- Do not block the air intake or exhaust vents. Blocking the vents may trap heat inside the projector, which may shorten the useful life of optical components or other parts and damage the projector.
- Install the projector leaving at least 50 cm (1.6') between air intake/exhaust vents and walls on each side of the projector. Leave a gap of at least 2 cm (0.8") from the bottom of the projector. There is an air intake underneath the projector. Failure to leave enough space may trap heat inside the projector and damage it.
- Do not place any objects on top of the projector that may change shape or color due to heat.
- Do not install the projector in a location that is damp, or where there is a lot of dust, oily smoke or tobacco smoke. Doing so could cause contamination of optical components such as the lens and the mirror and may result in deterioration of image quality.

Precautions When Carrying/Shipping the Projector

Note the following precautions when carrying or shipping the projector.



- **Disconnect the cables connected to the projector.** Carrying the projector with the cables attached may cause an accident.
- **Retract the adjustable feet.** Leaving the feet extended when the projector is moved may cause damage.
- **Do not expose the projector to strong impact or vibration.**
- **The projector is heavy and should not be carried alone.** Have at least one assistant.

Precautions for Installation

Be sure to read “Safety Instructions” and “For Safe Use” (P6 – P20). Also take the following precautions during installation.



- **Do not strike the projector or subject it to impact.** Doing so may cause a malfunction.
- **Do not install the projector standing on one side or in other unsteady positions.** The projector may be damaged if it tips over.

■ Do Not Use in the Following Environments



- **Locations with excessive humidity, dust, oily smoke or tobacco smoke**
Adhesion to the lens, mirrors or other optical parts may reduce image quality.
- **Near high-voltage power lines or sources of electrical power**
This may cause malfunction.
- **On soft surfaces such as carpets or cushioned mats**
Heat may build up inside the projector and damage it.
- **Locations with excessive temperature or humidity**
This may damage the projector. Acceptable ranges for operating and storage temperature and humidity are as follows.

| Operating temperature | Operating humidity | Storage temperature |
|---------------------------|--------------------|-----------------------------|
| 0°C (32°F) – 45°C (113°F) | Up to 85% | -20°C (-4°F) – 60°C (140°F) |

Before Installation

■ Do Not Touch the Lens with Bare Hands



Do not touch the lens with bare hands. Any smudges or fingerprints on the lens may affect image quality.

■ Allow a 30 Min. Warm Up before Focus Adjustment (P59), if Possible

Immediately after startup, the heat of the light source may prevent stable focus. When adjusting focus, it is also helpful to use the test pattern (10) (P116, P197).

■ Install at a Sufficient Distance from Walls and Other Obstructions



If the air intake or exhaust vent is blocked, heat will accumulate inside the projector, possibly resulting in a shortened projector lifetime or a malfunction. Similarly, do not install in narrow, enclosed spaces with poor ventilation. Install in a well-ventilated location. Ensure a minimum clearance of 50 cm (1.6') above, on both sides, and behind the projector, as shown below. Also ensure a minimum clearance of 2 cm (0.8") below the projector.

Air intake vent

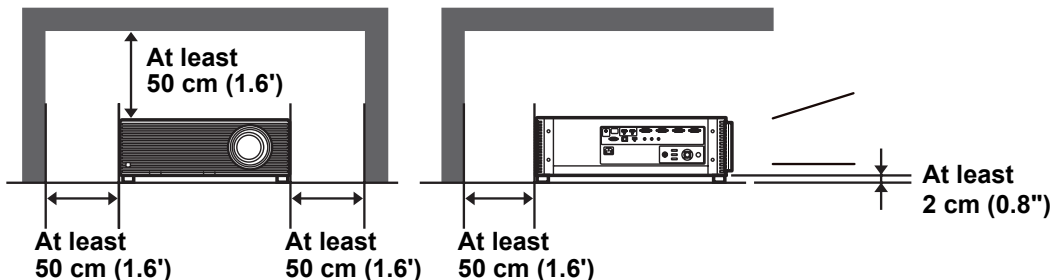
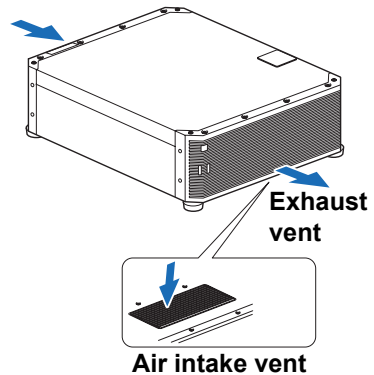

■ Be Careful of Condensation

If the temperature of the room rises suddenly, moisture in the air may condense on the projector lens and mirror, causing the image to become blurred. Wait until the condensation has evaporated for the image projected to return to normal.

■ At Altitudes above 2,300 m (7,545.8'), Adjust the Settings

Projector settings must be adjusted when using the projector at altitudes of 2,300 m (7,545.8') or higher. Specifically, refer to instructions for [High altitude] (P111) in the [Install settings] menu.

■ When Using Mounted on the Ceiling

When using the projector mounted on the ceiling or installed in a high location, clean around the air intake and exhaust vents periodically. Dust that accumulates in intake or exhaust vents may impair ventilation, raising the temperature inside and posing a risk of damage or fire. Use a vacuum cleaner or similar means to remove dust from the intake vent and exhaust vent.

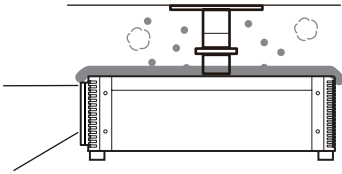

■ Installation to Project Up, Down, or at an Angle



- Projection is possible upward, downward, or in a variety of directions, but do not block the air intake and exhaust vents. In particular, always ensure a minimum clearance of 2 cm (0.8") from the air intake vent on the bottom of the projector.
- There are no options for installing the projector other than the ceiling attachment.
- When mounting the projector on the ceiling, it is more convenient to install the projector right-side up, with the adjustable feet facing down.

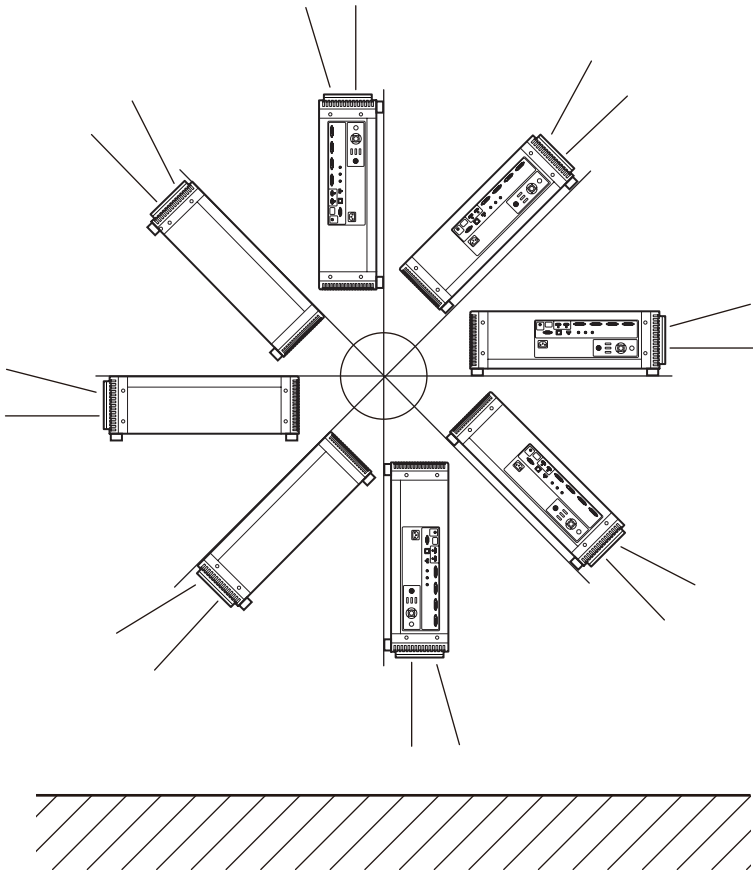

■ Precautions for Portrait (Upright) Installation

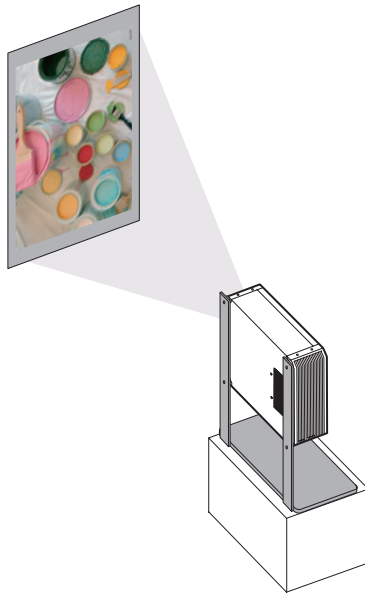

Caution

- Do not block the air intake or exhaust vents. In particular, because there is an air intake vent on the bottom, always ensure a minimum clearance of 2 cm (0.8") from the bottom.
- Note that no mounting brackets or similar accessories for portrait installation are available.

Copyright Notice

Please note that enlarging or reducing the size of an image for commercial purposes or public presentation may infringe on the legally protected copyright or the copyright holder of the original material.

Ensure Network Security

Take measures to ensure network security. Note that Canon is not liable in any way for direct or indirect loss from network security incidents, such as unauthorized access.

Before use, configure projector, computer, and network security settings appropriately.

- Set up the projector for connections only within your protected network, behind a firewall or the like, instead of direct Internet connections.
- When using the projector in a wireless network, also configure the Wi-Fi security settings.
- Change the Wi-Fi security key on a regular basis.

About Trademarks

- Ethernet is a registered trademark of Xerox Corporation.
- Microsoft, Windows, Windows Vista, Windows 7, Windows 8, Windows 8.1 and Windows 10 are registered trademarks or trademarks of Microsoft Corporation in the United States and / or other countries.
- Mac, Mac OS and Macintosh are trademarks of Apple Inc., registered in the United States and / or other countries.
- HDMI, the HDMI logo and High-Definition Multimedia Interface are trademarks or registered trademarks of HDMI Licensing, LLC.
- PJLink is a registered trademark of JBMIA and pending trademark in some countries.
- PJLink is a registered trademark, or an application has been submitted for trademark, in Japan, the United States and / or other countries or regions.
- AMX is a trademark of AMX Corporation.
- Crestron®, Crestron RoomView®, and Crestron Connected™ are registered trademarks of Crestron Electronics, Inc.
- Wi-Fi is a registered trademark of the Wi-Fi Alliance.
- Wi-Fi Certified, WPA, WPA2, and the Wi-Fi Certified logo are used in reference to methods of configuration developed by the Wi-Fi Alliance.
- All other trademarks are the property of their respective owners.

Open Source Software

The product contains Open Source Software modules. For details, see “ThirdPartySoftware.pdf” (Third-Party Software License) in the OpenSourceSoftware folder in the LICENSE folder on the Setup CD-ROM. Each module’s license conditions are also available in the same folder.

■ Software under the GNU General Public License Version 2

Contained programs are free software; you can redistribute them and/or modify them under the terms of the GNU General Public License attached to each copy of the program.

Each program is distributed in the hope that it will be useful, but WITHOUT ANY WARRANTY; without even the implied warranty of MERCHANTABILITY or FITNESS FOR A PARTICULAR PURPOSE. Please see “NO WARRANTY” and “NO SUPPORT” stated below. For more detail, please see full text of the GNU General Public License.

NO WARRANTY

BECAUSE THE PROGRAM IS LICENSED FREE OF CHARGE, THERE IS NO WARRANTY FOR THE PROGRAM, TO THE EXTENT PERMITTED BY APPLICABLE LAW. EXCEPT WHEN OTHERWISE STATED IN WRITING THE COPYRIGHT HOLDERS AND/OR OTHER PARTIES PROVIDE THE PROGRAM “AS IS” WITHOUT WARRANTY OF ANY KIND, EITHER EXPRESSED OR IMPLIED, INCLUDING, BUT NOT LIMITED TO, THE IMPLIED WARRANTIES OF MERCHANTABILITY AND FITNESS FOR A PARTICULAR PURPOSE. THE ENTIRE RISK AS TO THE QUALITY AND PERFORMANCE OF THE PROGRAM IS WITH YOU. SHOULD THE PROGRAM PROVE DEFECTIVE, YOU ASSUME THE COST OF ALL NECESSARY SERVICING, REPAIR OR CORRECTION.

IN NO EVENT UNLESS REQUIRED BY APPLICABLE LAW OR AGREED TO IN WRITING WILL ANY COPYRIGHT HOLDER, OR ANY OTHER PARTY WHO MAY MODIFY AND/OR REDISTRIBUTE THE PROGRAM AS PERMITTED ABOVE, BE LIABLE TO YOU FOR DAMAGES, INCLUDING ANY GENERAL, SPECIAL, INCIDENTAL OR CONSEQUENTIAL DAMAGES ARISING OUT OF THE USE OR INABILITY TO USE THE PROGRAM (INCLUDING BUT NOT LIMITED TO LOSS OF DATA OR DATA BEING RENDERED INACCURATE OR LOSSES SUSTAINED BY YOU OR THIRD PARTIES OR A FAILURE OF THE PROGRAM TO OPERATE WITH ANY OTHER PROGRAMS), EVEN IF SUCH HOLDER OR OTHER PARTY HAS BEEN ADVISED OF THE POSSIBILITY OF SUCH DAMAGES.

NO SUPPORT

Canon Inc., and all its subsidiaries or its dealers do not make any support service regarding the source code. Canon Inc., and all its subsidiaries or its dealers shall not respond to any questions or enquiries, from you or any other customers, regarding the source code.

Included Accessories

Before use, make sure the following items are included in the package.

- Remote control (part No.: RS-RC05)

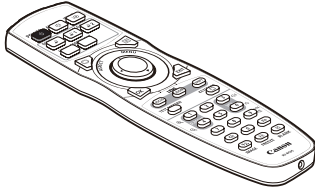

The remote control can also be used in a wired connection with the projector. (P36)

- Batteries for the remote control (AA size x2)

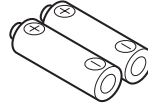

- Lens cap

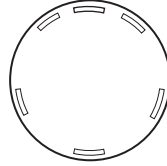

- Power cord (1.8 m / 5.9')

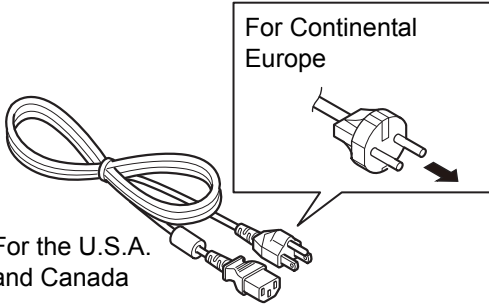

- User's Manual (CD-ROM)

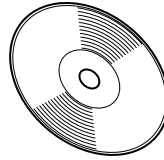

- Important Information

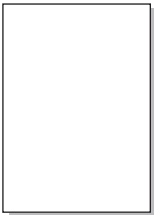

- Warranty Card

■ Lens Cap

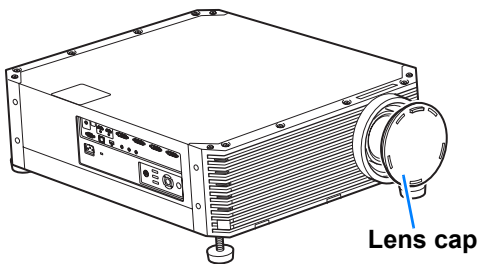

Always remove the lens cap before projection. Accidentally leaving the lens cap on during projection may distort the lens cap and damage the projector.

Part Names

Projector

■ Front Side

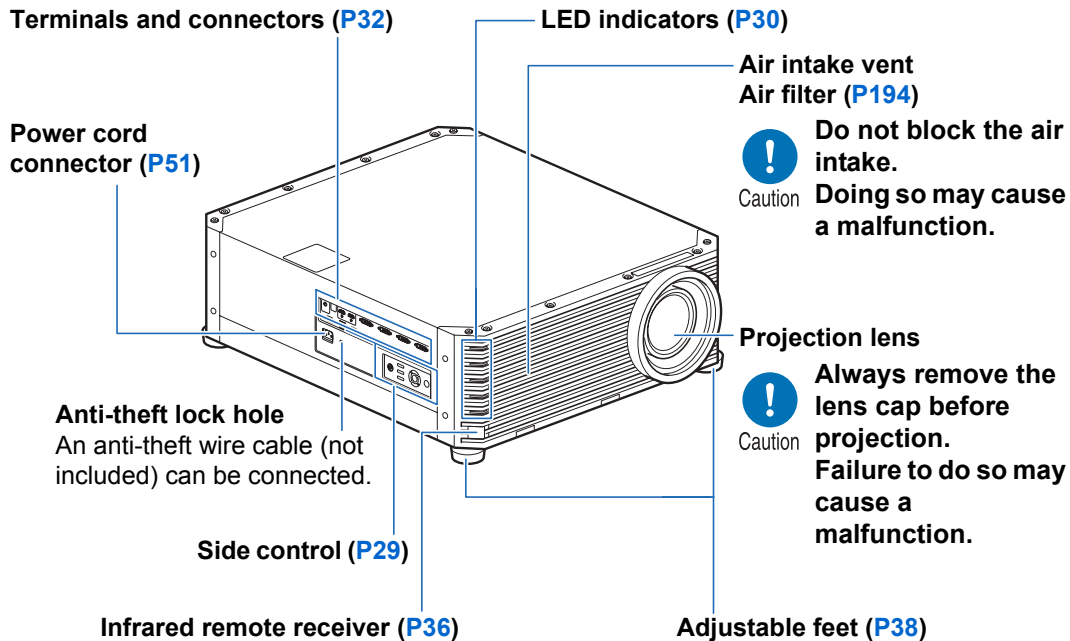

■ Rear Side

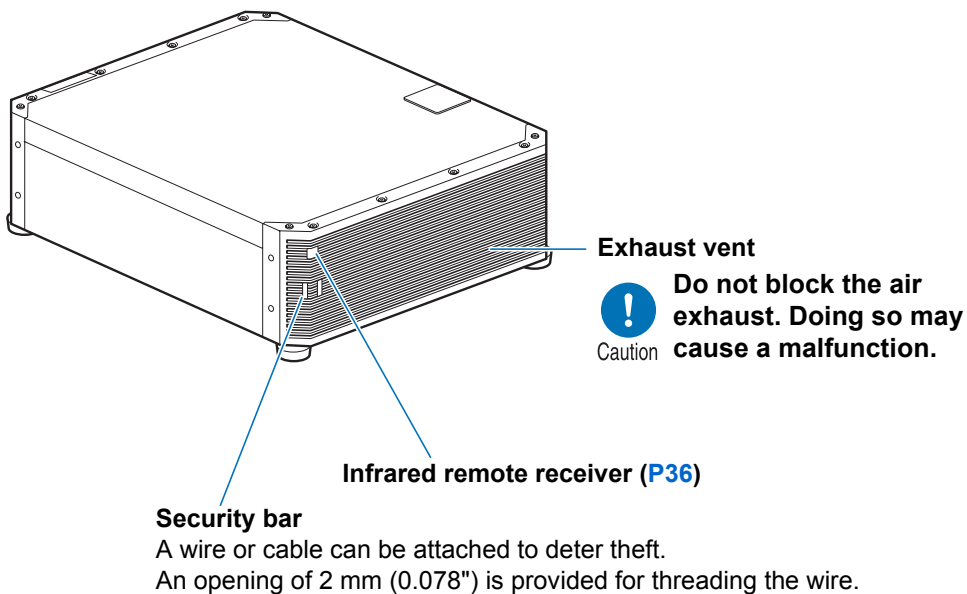

Bottom

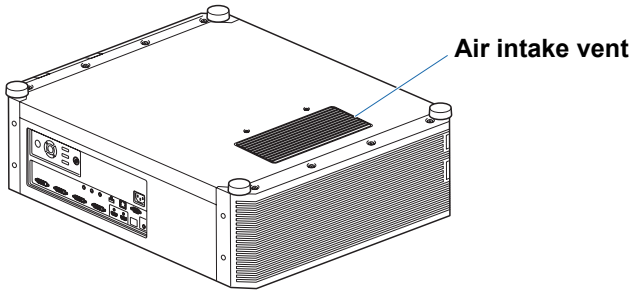

Side Control

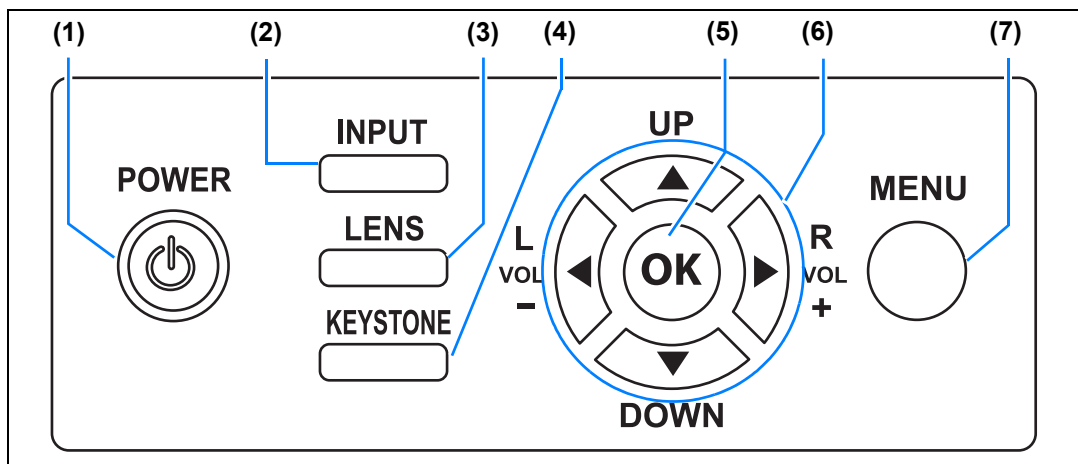

- | | |
|--|--|
| <p>(1) POWER button (P52, P71) Turns the projector on or off.</p> <p>(2) INPUT button (P55) Switches the input signal.</p> <p>(3) LENS button (P59) Each time the button is pressed, the adjustment window changes, from focus (P59) to zoom (image size) (P60) to lens shift (image position) (P62). To adjust the image, use the [▲] / [▼] or [◀] / [▶] buttons. After the focus adjustment window, the marginal focus adjustment window is also displayed for adjusting focus of image edges (P191), depending on the [Marginal focus] setting (P112).</p> | <p>(4) KEYSTONE button (P65) Corrects keystone distortion.</p> <p>(5) OK button (P78) Determines the item selected from the menu.</p> <p>(6) Pointer / VOL buttons (P77) Up, down, left, or right in menu navigation or other operations. Adjust the sound volume. [◀] VOL- button: Decreases the volume. [▶] VOL+ button: Increases the volume.</p> <p>(7) MENU button (P76) Displays a menu on the screen.</p> |
|--|--|

LED Indicators

The projector status is shown by the LED indicators (off / lit / flashing).

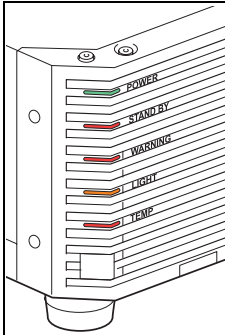























































- **POWER (green)** : Illuminated during projection. Otherwise, flashes in the following situations.
 - As the projector transitions from standby to projection
 - While the light source is off in power management mode
- **STANDBY (red)** : Illuminated during standby mode. Otherwise, flashes in the following situations.
 - As the projector transitions from projection to standby
 - While the light source is off in power management mode
- **WARNING (red)** : Lights up or flashes when an error occurs.
- **LIGHT (orange)** : Lights up or flashes when a problem occurs with the light source.
- **TEMP (red)** : Lights up or flashes when the internal temperature is high.

■ LED Indicator Displays

Projector operating status is indicated by five LEDs, as shown in the following table. For details on warnings, see “LED Indicator Details” (P208).

Example of when the POWER indicator is on; : Off : Lit : Flashing

| LED indicator | | | | | Operating status |
|---|---|---|---|---|--|
| POWER (green) | STANDBY (red) | WARNING (red) | LIGHT (orange) | TEMP (red) | |
|  |  |  |  |  | Projector not plugged in. |
|  |  |  |  |  | In standby mode. |
|  |  |  |  |  | Resuming operation (projection) after standby. |
|  |  |  |  |  | Cooling down while entering standby or power management mode from power on. |
|  |  |  |  |  | Power is on. (Projecting.) |
|  |  |  |  |  | In power management mode, with the light source off. (Flashes green and then red.) |
|  |  |  |  |  | Internal temperature is high. (In standby mode.) |
|  |  |  |  |  | Internal temperature is high. (During projection) |
|  |  |  |  |  | An error has occurred with the light source unit. |
|  |  |  |  |  | A temperature error has occurred. |
|  |  |  |  |  | Flashes 3 times: An air filter error has occurred. Flashes 4 times: A fan error has occurred. Flashes 5 times: A power error has occurred. |

Input Terminal

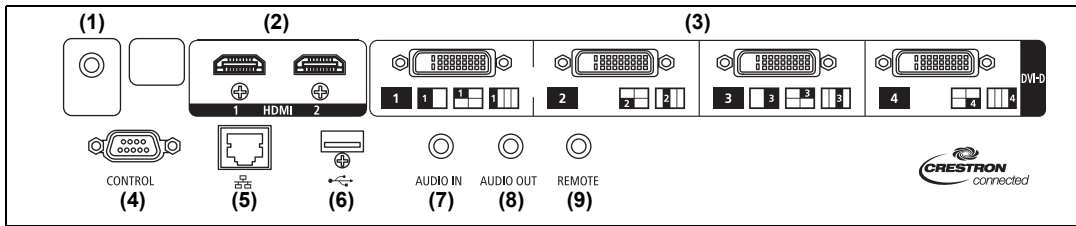

- (1) **Trigger terminal (TRIGGER) (P192)**
Used to trigger operation of a screen or other external device when the projector is turned on or off.
- (2) **HDMI terminal (HDMI) (P44, P45)**
Receives digital video signals (HDMI).
Carries both video and audio signals across a single cable.
- (3) **Digital PC / DVI-D terminal (DVI-D) (P44)**
Connects the external monitor output from a computer.
Receives digital PC signal (Digital PC).
- (4) **Service port (CONTROL) (P205)**
Used for executing user commands (P206 – P207).
- (5) **LAN port (P135)**
Connects the LAN cable (shielded twisted pair).
Used to connect the projector to a network.
- (6) **USB port (P134)**
Connects a USB flash drive. Used for firmware updates.
- (7) **AUDIO IN terminal (AUDIO IN) (P44)**
Receives audio input. Audio supplied to this terminal is played through the internal speaker when you select [Audio in] as the source audio terminal for the selected source video.
- (8) **AUDIO OUT terminal (AUDIO OUT) (P44, P45)**
Outputs the selected audio signal. (Connecting an audio cable to this terminal mutes the speaker.)
- (9) **Terminal for wired remote control (REMOTE) (P36)**
This terminal is used to connect the remote control using a cable.

Remote Control

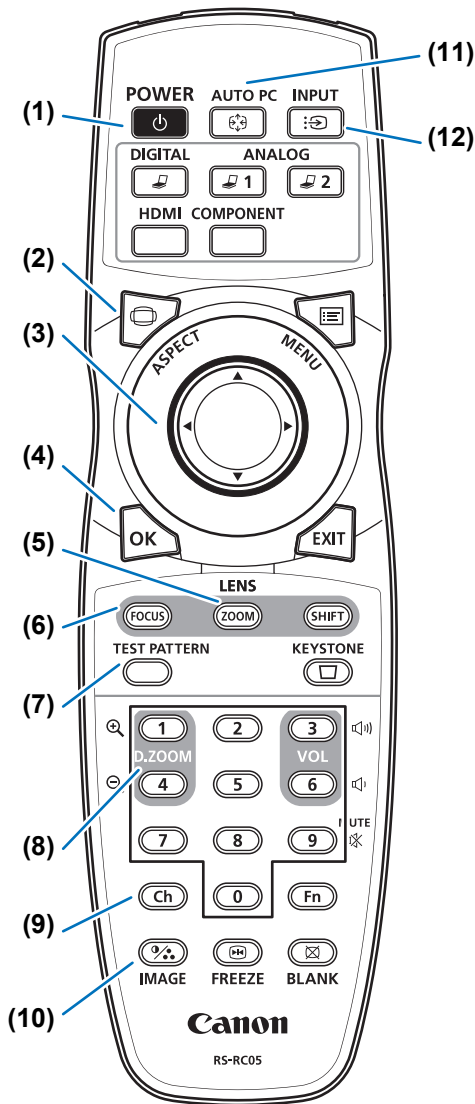

(1) POWER button (P52, P71)

Turns the projector on or off.

(2) ASPECT button (P64, P93)

Changes the aspect ratio mode.

(3) Pointer buttons (P77)

Selects the upper, lower, left or right item in the menu.

(4) OK button (P78)

Determines the item selected from the menu.

(5) ZOOM button (P60)

Adjusts the image size.

[▲] / [▶] buttons:

Increase the image size.

[▼] / [◀] buttons:

Decrease the image size.

(6) FOCUS button (P59)

Adjusts focusing.

[▲] / [▶] buttons:

Moves the focus position further away.

[▼] / [◀] buttons:

Moves the focus position nearer.

By pressing the **FOCUS** button twice, you can adjust the focus at image edges (P191).

[Marginal focus] setting (P112).

(7) TEST PATTERN button (P116)

Displays the test pattern.

(8) D.ZOOM button

Not used with this product.

(9) Ch button (P122)

Changes the remote control channel when the remote control is used via the infrared transmitter.

(10) IMAGE button (P68)

Switches the image mode (image quality).

(11) AUTO PC button

Not used with this product.

(12) INPUT button (P55)

Switches the input signal.

Before Use

(13) Change input buttons

Change the input signal between Digital PC and HDMI.

ANALOG 1, ANALOG 2 and **COMPONENT** are not used with this product.

(14) MENU button (P76)

Displays a menu on the screen.

(15) EXIT button (P79)

Cancels functions such as menu display or test pattern during operation and returns to the image display.

(16) SHIFT button (P62)

Shifts the image up, down, left, or right.

[▲] / [▼] / [◀] / [▶] buttons:

Moves the image.

(17) KEYSTONE button (P65)

Corrects keystone distortion.

The [Keystone] setting enables both horizontal/vertical keystone correction (by adjusting top/bottom/left/right length) and corner correction.

(18) VOL button

Adjusts the sound volume.

[▶] button, [3] button:

Increases the volume.

[◀] button, [6] button:

Decreases the volume.

(19) MUTE button

Mutes the sound.

(20) Numerical buttons (P127, P141, P144)

Enter password and TCP/IP setting values.

(21) Fn button

Not used with this product.

(22) BLANK button (P72)

Temporarily blacks out the image.

(23) FREEZE button (P72)

Freezes the projected image.

(24) Terminal for wired remote control (P36)

Connects the remote control to the projector, for remote control operation.

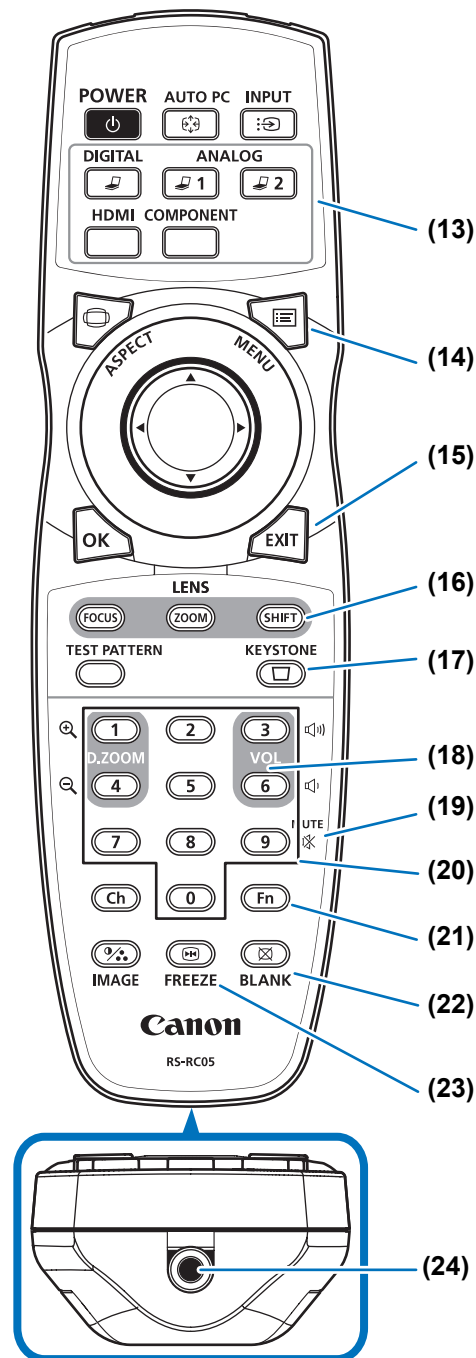

Preparing the Remote Control

■ Installing Remote Control Batteries

- 1 Open the battery compartment lid.**
Raise the battery cover tab while pushing it.

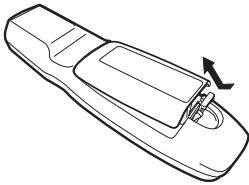

- 2 Insert batteries.**
Insert 2 new AA batteries in the compartment with the + and – terminals positioned correctly.

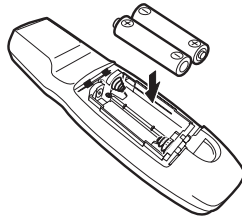

- 3 Close the compartment lid.**
Insert the tab into the remote control notch (1) and push the battery cover down (2).

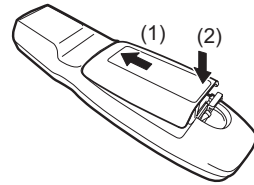

- If buttons on the remote control are inoperative when you attempt to operate the projector, replace the batteries with new ones.
- Do not drop the remote control or subject it to impact.
- Do not spill any liquids on the remote control. Doing so may cause a malfunction.



Warning



Prohibition

Pay attention to the following points when handling the batteries. Failing to do so could result in a fire or personal injury.

- Do not heat, short circuit or disassemble the batteries, or place them in a fire.
- Do not attempt to recharge the batteries that are included with the remote control.
- Remove the batteries when they are flat or when the remote control will not be used for a long period of time.
- When replacing the batteries, replace both at the same time. Also, do not use two batteries of a different type at the same time.
- Insert the batteries with the + and - terminals in the correct directions.
- If any liquid from inside the batteries leaks out and contacts your skin, be sure to wash the liquid off thoroughly.



Caution

■ Remote Control Operating Range

The remote control is an infrared type. Point it at the infrared remote receiver on the front or rear of the projector to operate it.

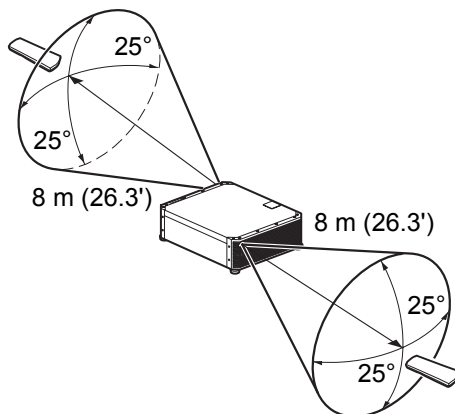

- Use the remote control within an angle of 25° in any direction from directly in front of the infrared remote receiver.
- The remote control may be inoperative if there is an obstacle between the remote control and the projector or the infrared remote receiver on the projector is exposed to direct sunlight or strong light of lighting equipment.
- When you use 2 or more projectors at the same time, you can change the channel settings to prevent the 2 remote controls from interfering with each other. (P122)

■ Using the Remote (RS-RC05) in a Wired Connection

The remote control can also be used in a wired connection with the projector. Use a cable with a ø3.5 mm stereo mini jack (not included).

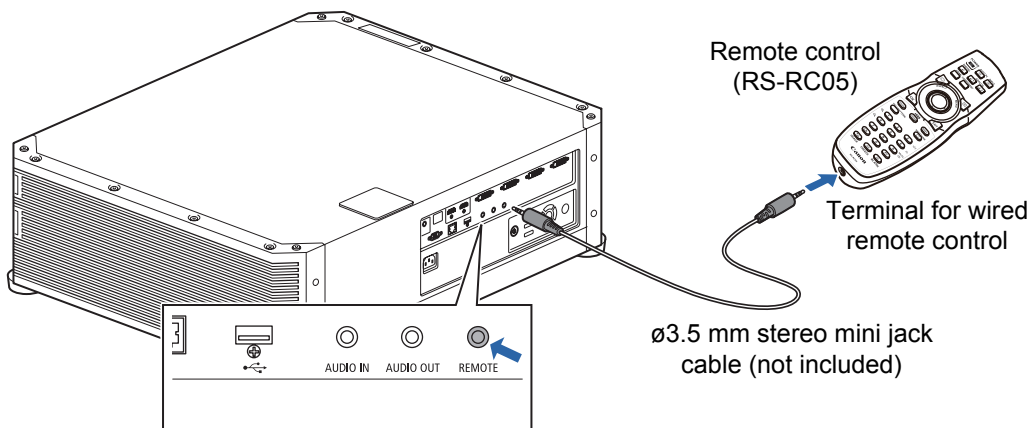

- Infrared operations cannot be performed if a cable is connected to the projector or the remote control.
- Use a cable with a ø3.5 mm stereo mini jack (not included) with a length of 30 m (98.4') or less.

Basic Guide

Safety Instructions

Before Use

Installation Procedure

Connection Procedure

Projection Procedure

Convenient Features

Using Menus

Menu Configuration

Menu Settings

Using the Projector on a Network

Advanced Projection

Maintenance

Product Specifications

Troubleshooting

Basic Guide

Advanced Guide

Other Information

Installation Procedure

Before setting up the projector, be sure to read “Before Installation” (P21).

Setting Up the Projector

■ Positioning the Projector in Front of the Screen

Place the projector in front of the screen.



- To avoid keystone distortion, install the projector so that it is at right angles to the screen.
- The screen must not be exposed to direct sunlight or light from lighting equipment. In a bright room, it is recommended that lights be turned off, curtains be drawn, and other steps taken to make the screen easier to see.
- Colors may appear distorted when images are viewed from the side on some screens. For best results, use a matte screen with a wide viewing angle.

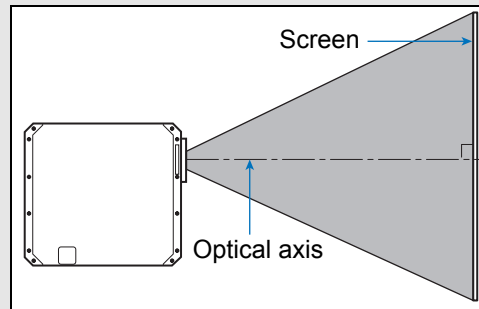

■ Floor Installation

To adjust the projection position when the projector is installed on the floor, use the lens shift function (P42, P62) to adjust the image up / down / left / right.

For information about the relationship between image size and projection distance, refer to [page 40](#).

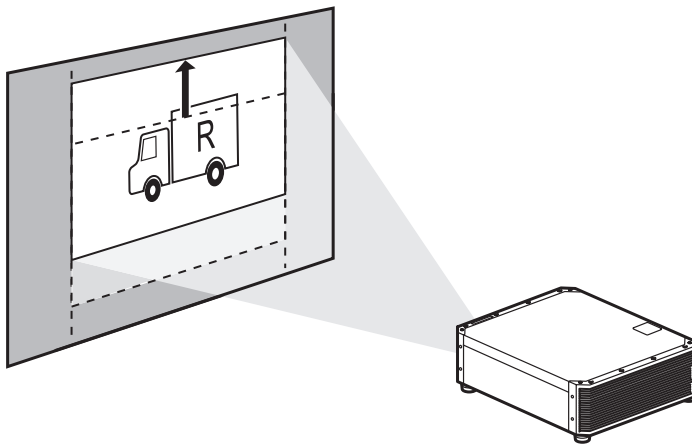

Lens shift

■ Installation on High Surfaces

Using the lens shift function (P42), you can project images toward a lower level. When setting the projector on a high surface for projection, make sure the surface is flat and stable, and install the projector right-side up with the adjustable feet facing down.

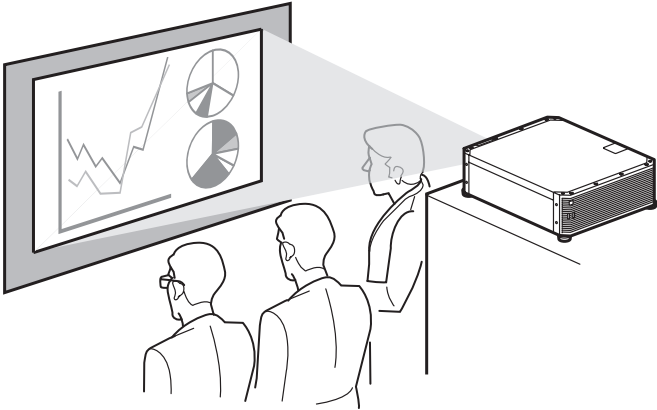

! The projector may fall and cause accidents or injury.
Caution

■ Ceiling Mounting or Rear Projection

You can mount the projector on the ceiling (ceiling mounting) or place it behind the screen (rear projection) if you use a translucent screen.

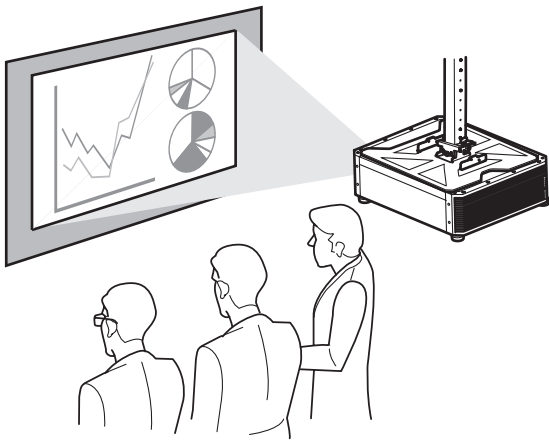

Ceiling mounting

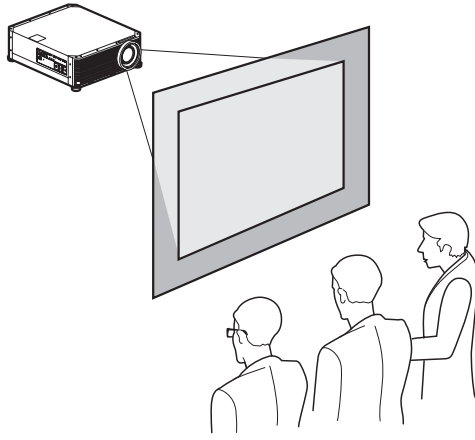

Rear projection

 When mounting the projector on the ceiling, it is more convenient to install the projector right-side up, with the adjustable feet facing down.

Relationship between Image Size and Projecting Distance

The projected image size is determined by the distance between the projector and screen (projection distance) and the zoom position (check specifications for details on the range in focus). Refer to the following table and decide the distance between the projector and screen.

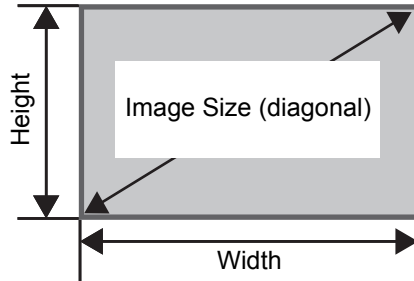

Relationship between image size and projecting distance (reference values)

| Image Size (Dia.) | 4096 x 2160 | | | | 4096 x 2400 | | | |
|----------------------|-------------------------|----------------|-----------------------------------|---------------|-------------------------|----------------|-----------------------------------|---------------|
| | Image Size [cm (in)] | | Projection distance [m (feet)] | | Image Size [cm (in)] | | Projection distance [m (feet)] | |
| | Width | Height | Wide limit | Tele limit | Width | Height | Wide limit | Tele limit |
| 40 | 90 (35.4) | 47 (18.5) | 0.9 (3.0) | 1.2 (3.9) | 88 (34.6) | 51 (20.1) | 0.9 (3.0) | 1.1 (3.6) |
| 60 | 135 (53.1) | 71 (28.0) | 1.3 (4.3) | 1.8 (5.9) | 131 (51.6) | 77 (30.3) | 1.3 (4.3) | 1.7 (5.6) |
| 80 | 180 (70.9) | 95 (37.4) | 1.8 (5.9) | 2.3 (7.5) | 175 (68.9) | 103 (40.6) | 1.8 (5.9) | 2.3 (7.5) |
| 100 | 225 (88.6) | 118 (46.5) | 2.2 (7.2) | 2.9 (9.5) | 219 (86.2) | 128 (50.4) | 2.2 (7.2) | 2.8 (9.2) |
| 120 | 270 (106.3) | 142 (55.9) | 2.7 (8.6) | 3.5 (11.5) | 263 (103.5) | 154 (60.6) | 2.6 (8.5) | 3.4 (11.2) |
| 140 | 315 (124.0) | 166 (65.4) | 3.1 (10.2) | 4.1 (13.5) | 307 (120.9) | 180 (70.9) | 3.1 (10.2) | 4.0 (13.1) |
| 160 | 359 (141.3) | 190 (74.8) | 3.6 (11.8) | 4.7 (15.4) | 351 (138.2) | 205 (80.7) | 3.5 (11.5) | 4.6 (15.1) |
| 180 | 404 (159.1) | 213 (83.9) | 4.0 (13.1) | 5.3 (17.4) | 394 (155.1) | 231 (90.9) | 3.9 (12.8) | 5.1 (16.7) |
| 200 | 449 (176.8) | 237 (93.3) | 4.5 (14.8) | 5.8 (19.0) | 438 (172.4) | 257 (101.2) | 4.4 (14.4) | 5.7 (18.7) |
| 220 | 494 (194.5) | 261 (102.8) | 4.9 (16.1) | 6.4 (21.0) | 482 (189.8) | 282 (111.0) | 4.8 (15.7) | 6.3 (20.7) |
| 240 | 539 (212.2) | 284 (111.8) | 5.4 (17.7) | 7.0 (23.0) | 526 (207.1) | 308 (121.3) | 5.3 (17.4) | 6.8 (22.3) |
| 260 | 584 (229.9) | 308 (121.3) | 5.8 (19.0) | 7.6 (24.9) | 570 (224.4) | 334 (131.5) | 5.7 (18.7) | 7.4 (24.3) |
| 280 | 629 (247.6) | 332 (130.7) | 6.3 (20.7) | 8.2 (26.9) | 614 (241.7) | 360 (141.7) | 6.1 (20.0) | 8.0 (26.2) |

| Image Size (Dia.) | 4096 x 2160 | | | | 4096 x 2400 | | | |
|----------------------|-------------------------|----------------|-----------------------------------|----------------|-------------------------|----------------|-----------------------------------|----------------|
| | Image Size [cm (in)] | | Projection distance [m (feet)] | | Image Size [cm (in)] | | Projection distance [m (feet)] | |
| | Width | Height | Wide limit | Tele limit | Width | Height | Wide limit | Tele limit |
| 300 | 674 (265.4) | 355 (139.8) | 6.7 (22.0) | 8.8 (28.9) | 657 (258.7) | 385 (151.9) | 6.6 (21.7) | 8.5 (27.9) |
| 350 | 786 (309.4) | 415 (163.4) | 7.9 (25.9) | 10.2 (33.5) | 767 (302.0) | 449 (176.8) | 7.7 (25.3) | 10.0 (32.8) |
| 400 | 899 (353.9) | 474 (186.6) | 9.0 (29.5) | 11.7 (38.4) | 877 (345.3) | 514 (202.4) | 8.8 (28.9) | 11.4 (37.4) |
| 450 | 1011 (398.0) | 533 (209.8) | 10.1 (33.1) | 13.1 (43.0) | 986 (388.2) | 578 (227.6) | 9.9 (32.5) | 12.8 (42.0) |
| 500 | 1123 (442.1) | 592 (233.1) | 11.2 (36.7) | 14.6 (48.0) | 1096 (431.5) | 642 (252.8) | 11.0 (36.1) | 14.2 (46.6) |
| 550 | 1236 (497.2) | 652 (256.7) | 12.3 (40.4) | 16.1 (52.8) | 1205 (474.4) | 706 (278.0) | 12.0 (39.4) | 15.7 (51.5) |
| 600 | 1348 (530.7) | 711 (279.9) | 13.5 (44.3) | 17.5 (57.4) | 1315 (517.7) | 770 (303.1) | 13.1 (43.0) | 17.1 (56.1) |

Lens Shift Function

You can reposition the image in all directions by pressing the **SHIFT** button on the remote control, which moves the lens up, down, left, or right. For instructions, refer to “Adjusting the Image Position” (P62).

■ Amount of Lens Shift

The amount of lens shift is indicated as a percentage relative to the image height and width. The lens shift ranges for the projector are as follows.

| | |
|--------------------------------|------|
| A (Amount of vertical shift) | ±60% |
| B (Amount of horizontal shift) | ±10% |

The lens can be shifted up or down and to the left or right. Performance using lens shift is ensured within the recommended range described below. However, peripheral dimness or blurriness may occur in the corners outside the last 10% of the horizontal lens shift range and outside the last 15% of the vertical lens shift range. In this case, adjust lens shift to within the recommended range.

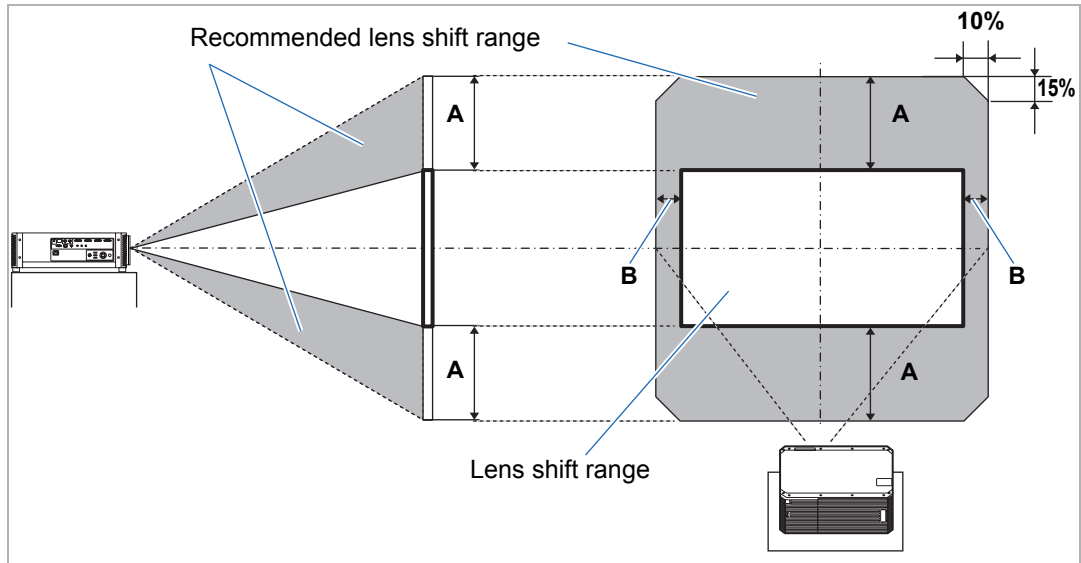

Maximum vertical (A) and horizontal (B) movement using lens shift
(reference values [cm (in)])

| Image size (Dia.) | 4096 x 2160 | | 4096 x 2400 | |
|-------------------|-------------|------------|-------------|------------|
| | A | B | A | B |
| 40 | 28 (11.0) | 9 (3.5) | 31 (12.2) | 9 (3.5) |
| 60 | 43 (16.9) | 13 (5.1) | 46 (18.1) | 13 (5.1) |
| 80 | 57 (22.4) | 18 (7.1) | 62 (24.4) | 18 (7.1) |
| 100 | 71 (28.0) | 22 (8.7) | 77 (30.3) | 22 (8.7) |
| 120 | 85 (33.5) | 27 (10.6) | 92 (36.2) | 26 (10.2) |
| 140 | 100 (39.4) | 31 (12.2) | 108 (42.5) | 31 (12.2) |
| 160 | 114 (44.9) | 36 (14.2) | 123 (48.4) | 35 (13.8) |
| 180 | 128 (50.4) | 40 (15.7) | 139 (54.7) | 39 (15.4) |
| 200 | 142 (55.9) | 45 (17.7) | 154 (60.6) | 44 (17.3) |
| 220 | 156 (116.9) | 49 (19.3) | 169 (66.5) | 48 (18.9) |
| 240 | 171 (67.3) | 54 (21.3) | 185 (72.8) | 53 (20.9) |
| 260 | 185 (72.4) | 58 (22.8) | 200 (78.7) | 57 (22.4) |
| 280 | 199 (78.3) | 63 (24.8) | 216 (85.0) | 61 (24.0) |
| 300 | 213 (83.9) | 67 (26.4) | 231 (90.9) | 66 (26.0) |
| 350 | 249 (98.0) | 79 (31.1) | 270 (106.3) | 77 (30.3) |
| 400 | 284 (111.8) | 90 (35.4) | 308 (121.3) | 88 (34.7) |
| 450 | 320 (126.0) | 101 (39.8) | 347 (136.6) | 99 (39.0) |
| 500 | 355 (139.8) | 112 (44.1) | 385 (151.6) | 110 (43.3) |
| 550 | 391 (153.9) | 124 (48.8) | 424 (166.9) | 121 (47.6) |
| 600 | 427 (168.1) | 135 (53.1) | 462 (181.9) | 131 (52.6) |



- (A) values are the approximate vertical lens shift distance from the central image position within the supported lens shift range.
- (B) values are the approximate horizontal lens shift distance from the central image position within the supported lens shift range.
- Watch the projected image as you adjust it using lens shift.
- When the image no longer moves, you have reached the limit of the lens shift range.

Connection Procedure



Caution

Before connecting the projector to other equipment, turn off both the projector and the other equipment.



For instructions on connecting multiple sources of input for 4K projection, refer to “4K Projection” (P46).

Connecting a Computer

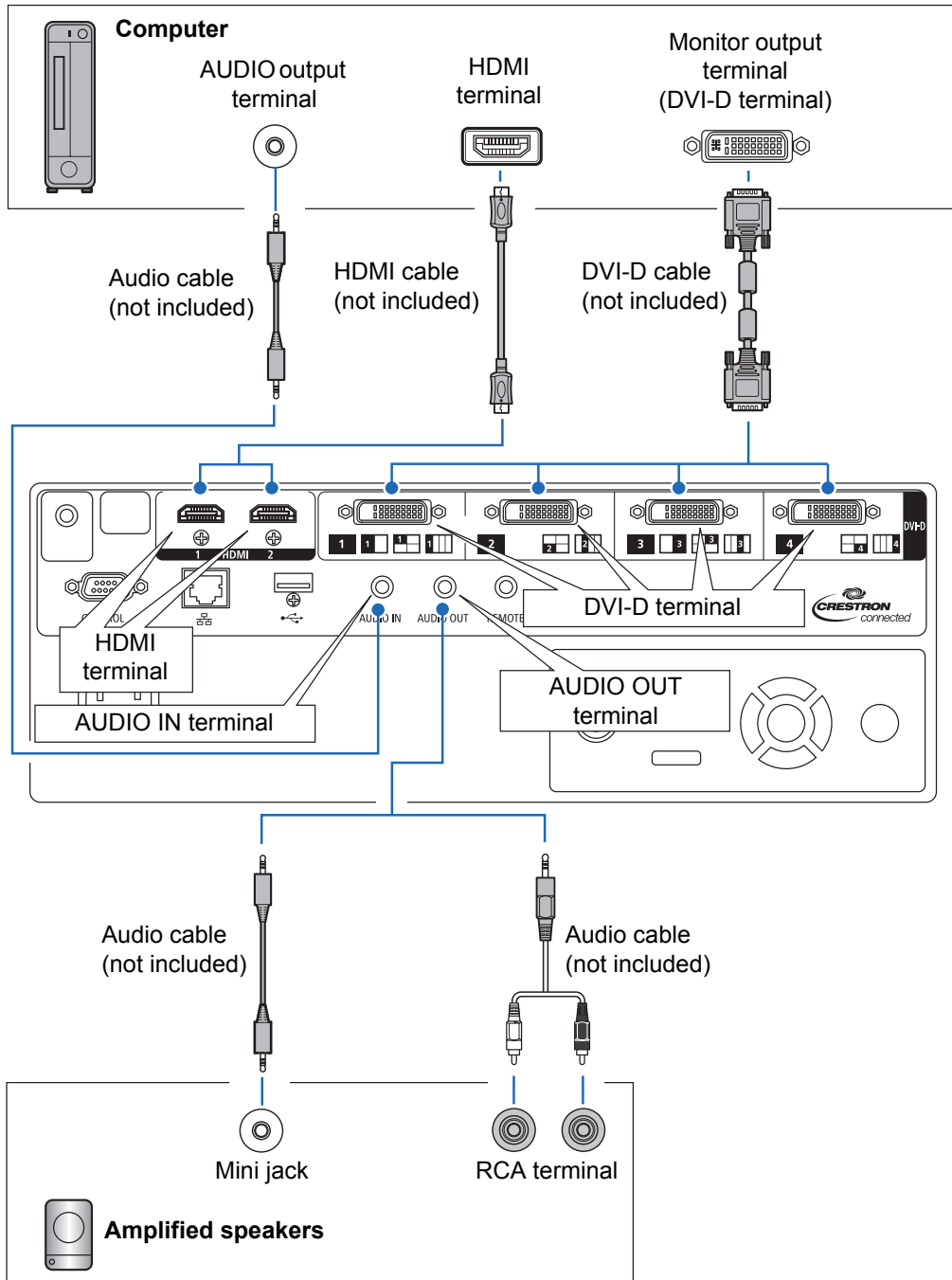

Connecting AV Equipment

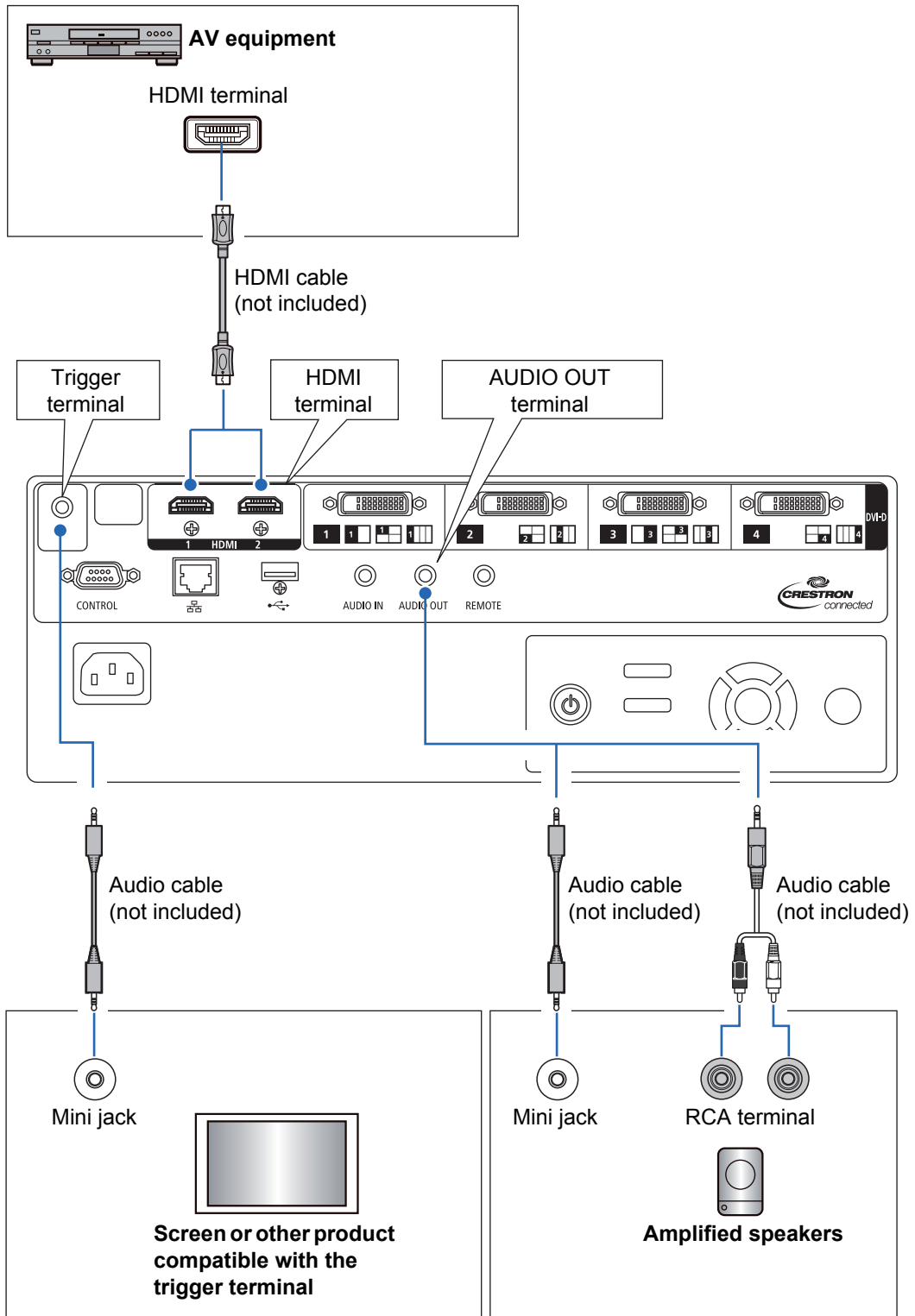

4K Projection

■ Definition of 4K

Several resolution specifications are described as being 4K, including 3840 x 2160, 3840 x 2400, 4096 x 2160, and 4096 x 2400, as shown in the following comparative simulation.

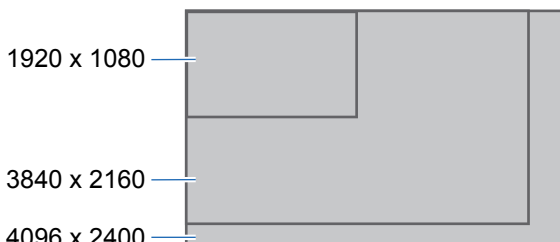

The projector supports input signals at resolutions up to the maximum 4K resolution of 4096 x 2400.

For details, check the table of supported signals. (P198)

■ 4K Digital Signal Compatibility

The projector is equipped with DVI-D and HDMI: 2 (4K / Deep Color / HDCP 2.2*1) inputs.

DVI-D input is classified as single-link or dual-link, depending on the dot clock. Projecting resolutions with a dot clock higher than 165 MHz requires a dual-link plug and cable.

Main DVI-D input resolutions

- 4096 x 2160 (dual-link; vertical frequency: 24 Hz)

Main HDMI 2.0 input resolutions

- 3840 x 2160 (vertical frequency: 60 Hz)
- 4096 x 2160 (vertical frequency: 60 Hz)

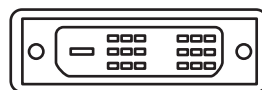

Single-link plug

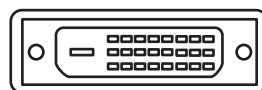

Dual-link plug

| Resolution | QFHD (3840 x 2160) | | | | | | | |
|---------------------------------------|--------------------|--------|-------|--------|-------|--------|-------|--------|
| | 24 Hz | | | | 60 Hz | | | |
| Frequency | 422 | | 444 | | 422 | | 444 | |
| Subsampling | 8 bit | 10 bit | 8 bit | 10 bit | 8 bit | 10 bit | 8 bit | 10 bit |
| HDMI 1.4 (10.2 Gbps bandwidth) x 1 | ○ | ○ | ○ | — | — | — | — | — |
| HDMI 2.0*2 (18 Gbps bandwidth) x 1 | ○ | ○ | ○ | ○ | ○ | ○ | ○ | — |

| Resolution | DCI (4096 x 2160) | | | | | | | |
|---|-------------------|--------|-------|--------|-------|--------|-------|--------|
| | 24 Hz | | | | 60 Hz | | | |
| Frequency | 422 | | 444 | | 422 | | 444 | |
| Subsampling | 422 | | 444 | | 422 | | 444 | |
| Color depth | 8 bit | 10 bit | 8 bit | 10 bit | 8 bit | 10 bit | 8 bit | 10 bit |
| HDMI 1.4 (10.2 Gbps bandwidth) x 1 | ○ | ○ | ○ | — | — | — | — | — |
| HDMI 2.0* ² (18 Gbps bandwidth) x 1 | ○ | ○ | ○ | ○ | ○ | ○ | ○ | — |

*1 HDCP, short for High-bandwidth Digital Content Protection, is a form of digital copy protection that prevents illegal copying of content by encrypting digital signals carried via HDMI from playback devices such as computers to display devices such as projectors. HDCP specifications are established and managed by Digital Content Protection, LLC.

*2 Use an HDMI cable supporting 18 Gbps.

■ Multi Input Mode

- DVI-D

Using four DVI-D dual-link cables, you can supply signals up to 4096 x 2400 (vertical frequency: 60 Hz). The signals supplied by the four cables are combined to form a single image.

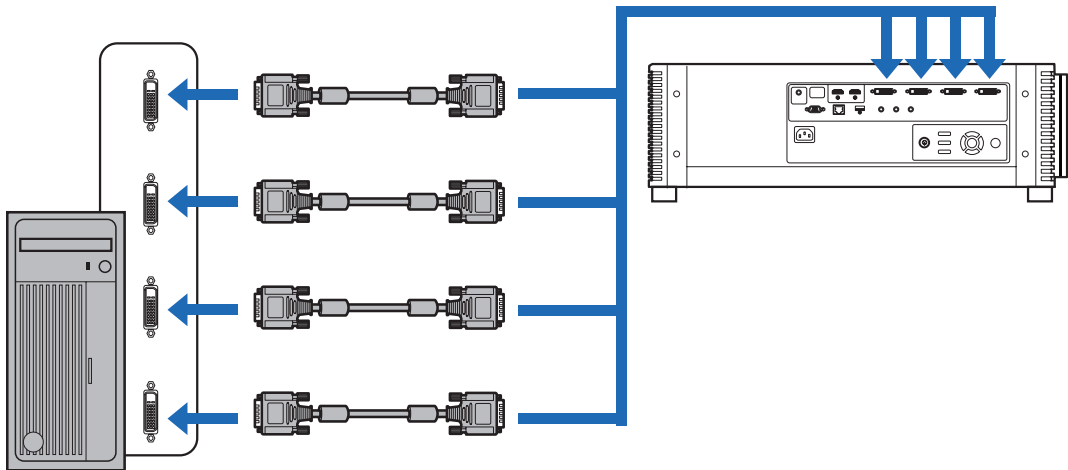

Connect workstations by using four dual-link DVI cables

Connection Procedure

- HDMI

Using two HDMI cables, you can project 4096 x 2160 (vertical frequency: 60 Hz) signals as one image. The signals supplied by the two cables are combined to form a single image.

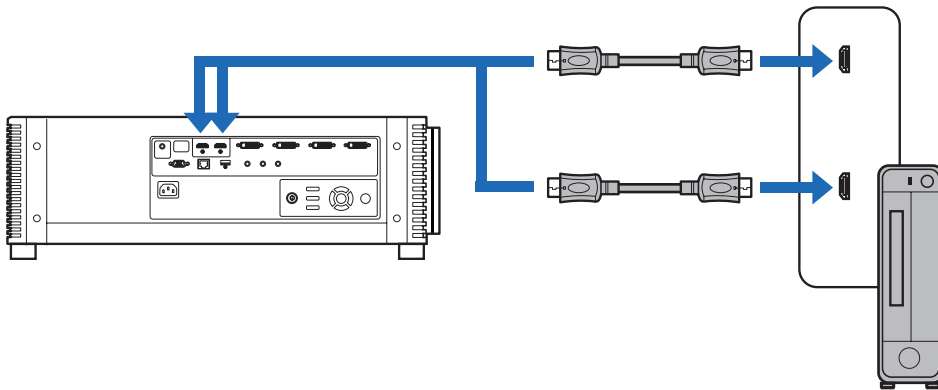

Connect desktop computers by using two HDMI cables



- Split-screen or four-quadrant projection is not supported when the projector is connected to multiple devices.
- A single image cannot be projected by using two HDMI 2.0 cables with 4096 x 2160 signals (vertical frequency: 120 Hz).

■ Settings for Multi Input Mode

Select how to combine two HDMI inputs or four DVI inputs to form an image. Check computer video output settings in advance, because you must match the display layout (whether split-screen display or display in four quadrants).



Multi Input Mode

Specify the type of image (including resolution) supplied to the terminals. Use [Normal] for most signals. For specific signals, use [Single], [1x2], [2x2], or [1x4] as needed. For details, check the table of supported signals. (P198)

- [Normal] setting
Supports many typical images, including [Single], [1x2], [2x2], and [1x4].
- [Single] setting
Supports many specialized signals using a single terminal.
- [1x2] setting
Supports many specialized signals using two input terminals.
- [2x2] setting
Supports many specialized signals using four input terminals, for projection in a 2x2 layout.
- [1x4] setting
Supports many specialized signals using four input terminals, for projection side by side.

For instructions on turning the projector on, see “Step 1 Turn the Projector On” (P52).

1 In the [Install settings] menu, select [Professional settings] > [Multi input mode select].

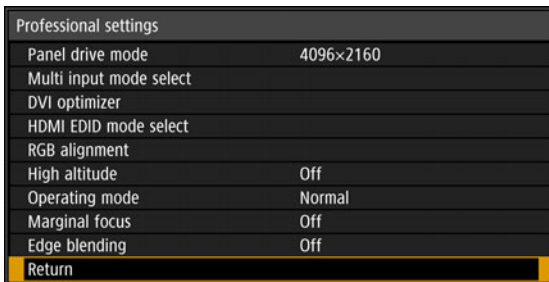

2 Select the input mode to use.

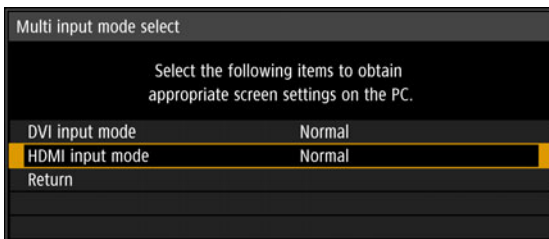

Connection Procedure

DVI input mode

Specify the combination of DVI input. Choose from [Normal], [Single], [DVI 1x2], [DVI 2x2], or [DVI 1x4].

- To use signals not included in [Normal] (P200 – P201) when multi input in the [Input] menu (P55) is set to [DVI 1x2], [DVI 2x2], or [DVI 1x4], set the DVI input mode menu to [DVI 1x2], [DVI 2x2], or [DVI 1x4].
- To use signals not included in [Normal] (P199) when single input in the [Input] menu (P55) is set to [DVI-1], [DVI-2], [DVI-3], or [DVI-4], set the DVI input mode menu to [Single].

HDMI input mode

Specify the combination of HDMI input. Choose from [Normal], [Single], or [HDMI 1x2].

- To use signals not included in [Normal] (P199) when multi input in the [Input] menu (P55) is set to [HDMI 1x2], set the HDMI input mode menu to [HDMI 1x2].
- To use signals not included in [Normal] (P198) when single input in the [Input] menu (P55) is set to [HDMI-1] or [HDMI-2], set the HDMI input mode menu to [Single].

When this setting is set to [Normal], the EDID (unique ID that conveys to computers the model name and setting values of connected display devices) is a list that consists of video signals used with one or multiple projector terminals. On the video output equipment, you can specify video signals for use with a different number of terminals.



[Multi input mode select] window is displayed automatically if the input terminals do not match the settings configured by using the **INPUT** button.

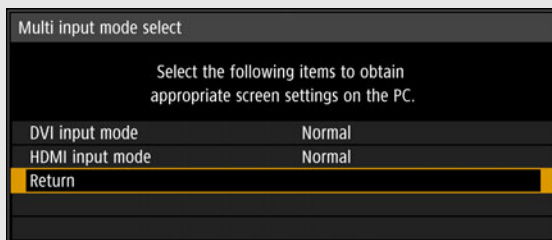

Plugging the Projector In

Connect the power cord to the projector and plug it in.

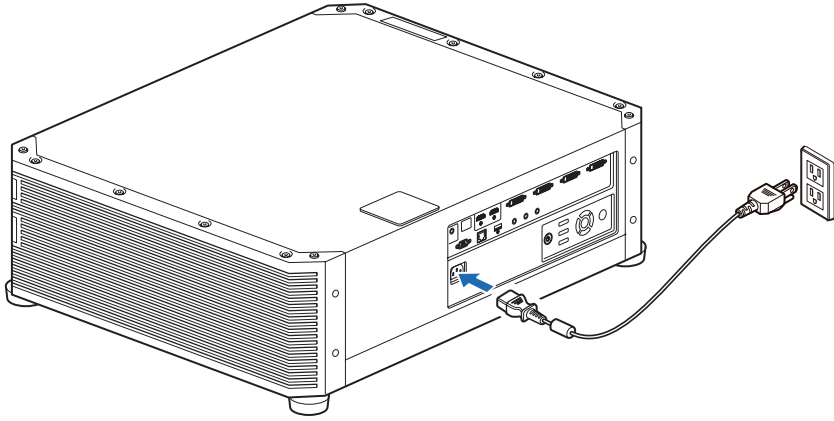

- Unplug the power cord when the projector is not in use for an extended period.
- [Date and time settings] may be reset if the projector is left unplugged for an extended period. (P128)

Projection Procedure

Step 1 Turn the Projector On

- 1 Check the connection between the projector and the computer or AV equipment. (P44, P45)**
For instructions on connecting the power cord, refer to “Plugging the Projector In” (P51).
- 2 Press the POWER button.**
The [POWER] indicator initially flashes green, after which it remains lit.

Remote control

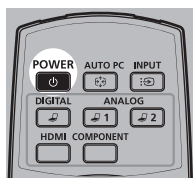

Projector

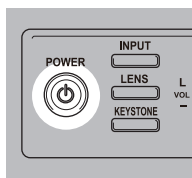

The countdown window is displayed for approximately 20 seconds, and then the projection is started. Press the **OK** or **EXIT** button to hide the countdown window.



- Network functions are not available until about 40 seconds after you plug the projector in.
- Some noise may appear in the projected image during the first few minutes, until the image stabilizes.

- 3 Turn on the computer or AV equipment power.**
Images from the computer or AV equipment are now projected.

Changing Operations When Projector is Turned On

You can change operations when the projector is turned on as follows.

- You can turn on the projector by connecting the power cord, without pressing the **POWER** button. (P125)
- You can change the countdown window. (P118)
- You can skip the countdown window. (P118)
- For faster startup next time, you can store projector status immediately before the projector is turned off. (P124)

When the Projector Is Left Idle

If no signal is received, the power management feature automatically turns off the projector after a certain period of inactivity (by default, 15 minutes). (P124)

■ When the Language Selection Screen Appears

A screen appears when the projector is turned on for the first time. You can select a language to be used by the projector for displaying menus and messages in the window. Select the desired language with the pointer buttons and press the **OK** button.

You can change the language from the menu at a later time. (P126)

If the language selection screen is out of focus, adjust the focus. (P59)

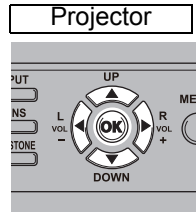
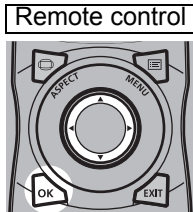

| Language | | |
|-----------|------------|---------|
| English | Русский | Čeština |
| Deutsch | Nederlands | Dansk |
| Français | Suomi | إنجليزي |
| Italiano | Norsk | 中文简体 |
| Español | Türkçe | 中文繁體 |
| Português | Polski | 한국어 |
| Svenska | Magyar | 日本語 |

An item highlighted in orange will be selected.

■ When the Password Input Screen Appears

If you have set a password, the password input screen appears. Enter your password. (P127)

■ When “No signal” Appears

With a notebook computer, the user must turn on the external monitor output. (P54)
Press the **INPUT** button to select the input signal. (P55)

■ When Notebook Computer Screen Does Not Appear

Set your notebook computer to output signals to an external monitor. For more details, refer to “Changing Notebook Computer Screen Output” (P54).

■ Adjusting Image

- Set the display resolution of the computer to the highest resolution or the resolution closest to that setting. (P57)
- Use the **ZOOM** button on the remote control to resize the projected image. (P60)
- If the image is blurry, use the **FOCUS** button on the remote control to adjust focus. (P59)
- If necessary, correct keystone distortion by pressing the **KEYSTONE** button. (P65)
- Select a screen mode (aspect) according to the aspect ratio of the screen, type of input image signal etc. (P64)
- Select an image mode depending on the projected image. (P68)



A variety of test patterns (P197) can be projected, which are convenient in image adjustment.

Changing Notebook Computer Screen Output

For projection from a notebook computer, the computer settings must be adjusted to switch display output.

This operation is not required for a desktop computer.

■ Turning on External Monitor Output

You can turn on the external monitor output via keyboard operation.

To turn on the external monitor output with most computers, press the function key ([F1] to [F12]) which is marked with the external monitor icon while holding down the [Fn] key.

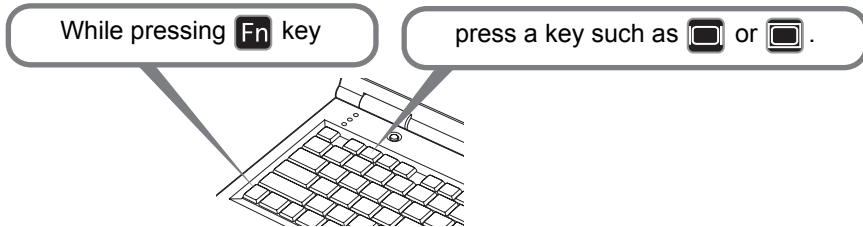

- The function key you use and the method used to turn on the external monitor output vary depending on the model. For details, see the manual for your notebook computer.
- With Windows 10, Windows 8.1, Windows 8 or Windows 7, you can turn on image output by holding down the Windows logo key and pressing the [P] key.

Step 2 Select an Input Signal

Select the input signal in the [Input] menu when you want to project a digital PC or AV equipment signal, or to switch between inputs when multiple computers or multiple sets of AV equipment are connected.

Skip this step if you have not changed the input signal since the last projection.

1 Press the **INPUT** button to display the window shown below.

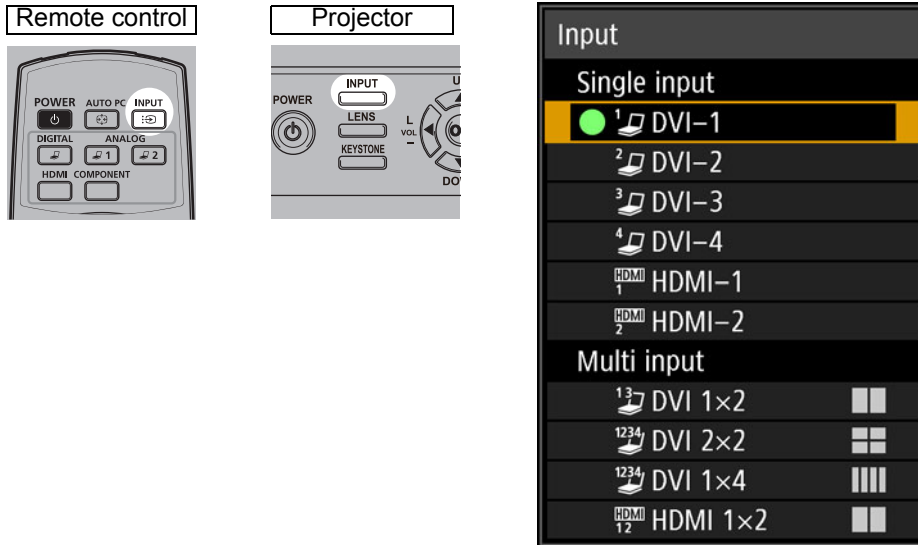

The currently active input signal is marked with a green circle and enclosed by a orange border.

Names of input signals available for projection are displayed in white, and unavailable signal names are grayed out.

2 Press the **[▲]** / **[▼]** buttons to select the input signal.

You can also switch from one DVI-D input source to the next by pressing the **DIGITAL** button, or from one HDMI input source to the next by pressing the **HDMI** button.

3 Press the OK button to confirm the input signal type.

For multiple input signals, the projection layout is divided as follows. The numbers 1, 2, 3, and 4 in squares represent the numbers of input terminals.

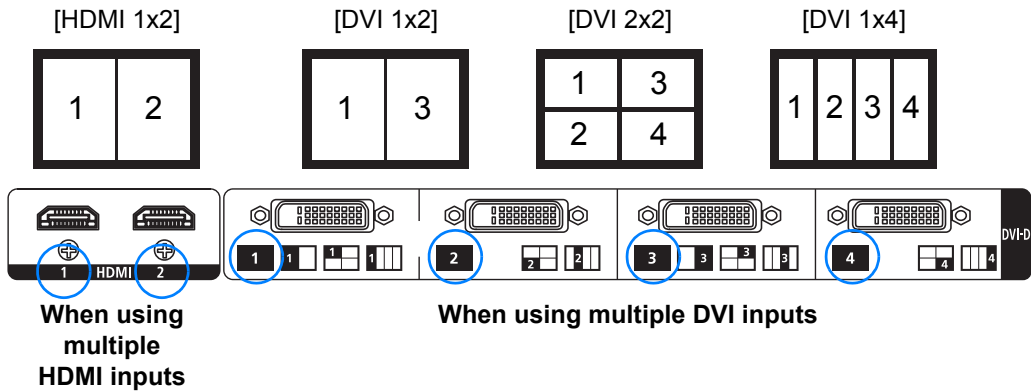

- You can also switch to your preferred input signal for projection by pressing buttons on the remote control to switch input signals (specifically, the **DIGITAL** or **HDMI** button).
- Using the projector's multi-input feature, you can supply a single image via two or four cables. As sources of input for projection at 4K or other resolutions, choose from [DVI 1x2], [DVI 2x2], [DVI 1x4], or [HDMI 1x2]. (P46)
- Signals you supply for Multi Input mode must meet certain conditions. If the signals do not meet these requirements, a "!" icon is displayed.

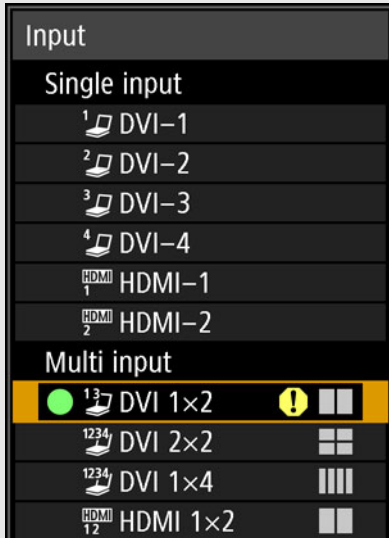

Step 3 Adjust the Image

Setting the Display Resolution of the Computer

Based on the maximum resolution of the projector, set the display resolution of the computer to the resolution closest to the output signal resolution of the projector. (P198)

Maximum resolution

- 4096 x 2160: When [Panel drive mode] is set to [4096x2160].
- 4096 x 2400: When [Panel drive mode] is set to [4096x2400].

For details on the Panel drive mode, see [Panel drive mode] in [Professional settings] (P108).

■ Windows 10

- 1 Open the [Control Panel] from the start menu, then select [Appearance and Personalization] - [Adjust screen resolution] in the [Control Panel Home].
- 2 Click the [Resolution] tab, and move the slider to select the resolution closest to the maximum output signal resolution of the projector.
- 3 Click the [OK] button.

■ Windows 8.1 / Windows 8

- 1 Move the cursor toward the upper or lower right corner to access the menu.
- 2 Click [Settings], and then click [Control Panel].
- 3 From [Control Panel Home] - [Appearance and Personalization], select [Adjust screen resolution].
- 4 Click the [Resolution] tab, and move the slider to select the resolution closest to the maximum output signal resolution of the projector.
- 5 Click the [OK] button.

■ Windows 7

- 1 Open the [Control Panel] from the start menu, then select [Appearance and Personalization] - [Adjust screen resolution].
- 2 Click the [Resolution] tab, and move the slider to select the resolution closest to the maximum output signal resolution of the projector.
- 3 Click the [OK] button.

■ Windows Vista

- 1** Open the [Control Panel] from the start menu, then select [Appearance and Personalization] - [Adjust screen resolution] in the [Control Panel Home].
- 2** Select the resolution closest to the maximum output signal resolution of the projector from the [Resolution] list.
- 3** Click the [OK] button.

■ Mac OS X

- 1** Open the Apple Menu and select [System Preferences].
- 2** In the [System Preferences] window, click the [Displays] icon to display the Display window.
- 3** Select the [Display] tab and select the resolution closest to the maximum output signal resolution of the projector from the [Resolutions] list.
- 4** Close the [System Preferences] window.

Focusing, Resizing, or Moving the Image

■ Adjusting Image Focus

To adjust the focus, press the **FOCUS** button on the remote control or the **LENS** button on the projector.

- 1 Press either the **FOCUS** button on the remote control or the **LENS** button on the projector to display the focus adjustment window.

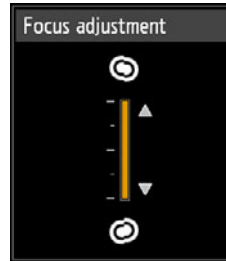
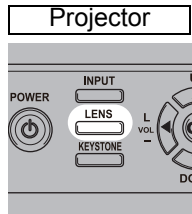
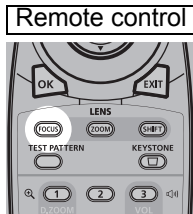

- 2 Press the pointer buttons to adjust the focus.

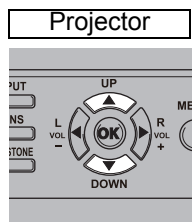
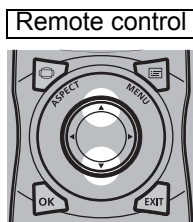

To adjust the focus, use the [▲] / [▼] button on the remote control or projector.

- 3 When the focus is adjusted optimally, press the **OK** button or the **FOCUS** button.



When projecting on curved screens, you can adjust the focus at image edges. Refer to “Marginal focus” (P112) and “Adjusting Peripheral Focus” (P191).

■ Adjusting Image Size

The size of the projected image can be adjusted by pressing the **ZOOM** button on the remote control or the **LENS** button on the projector. Change the projector installation position if your desired image is too large or too small to adjust it with the zoom function. (P38)

- 1 Press the **ZOOM** button on the remote control to display the zoom adjustment window.

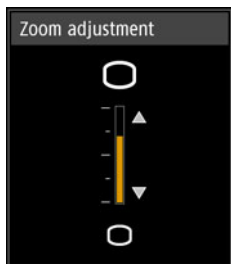
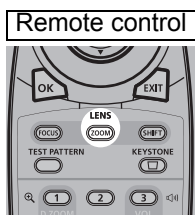

Press the **LENS** button on the projector repeatedly to switch between windows for parameters adjusted by controlling the lens. To access the zoom adjustment window, press the **LENS** button twice (or three times if you have set [Marginal focus] to [On]).

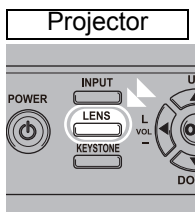

Press twice.

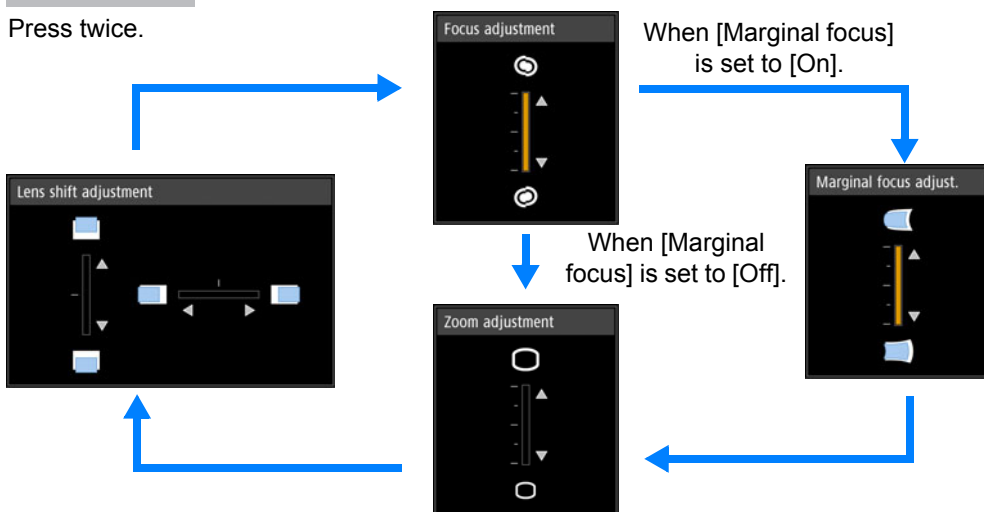

2 Press the pointer buttons to adjust the image size.

Remote control

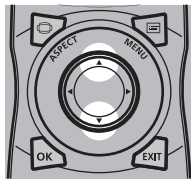

Projector

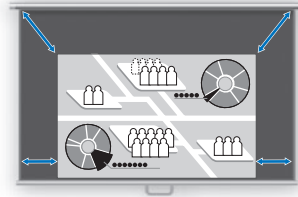
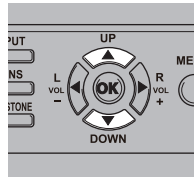

Screen

To enlarge the image, use the [▲] button on the remote control or projector.
To reduce the image, use the [▼] button on the remote control or projector.

3 When the desired image size is selected, press the OK button or the ZOOM button.

■ Adjusting the Image Position

To adjust the screen position up, down, left, or right, press the **SHIFT** button on the remote control or the **LENS** button on the projector. It can change the projected screen to the most suitable position by moving the position of the lens up/down/left/right. (P42)

- 1 Press the SHIFT button on the remote control to display the lens shift adjustment window.**

Remote control

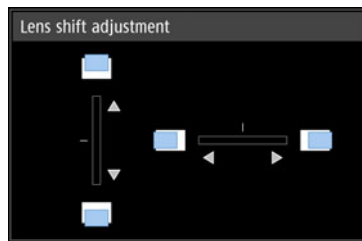
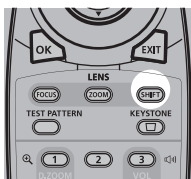

Press the **LENS** button on the projector repeatedly to switch between windows for parameters adjusted by controlling the lens.

To access the lens shift adjustment window, press the **LENS** button three times (or four times if you have set [Marginal focus] to [On]).

Projector

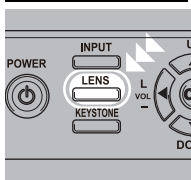

Press three times.

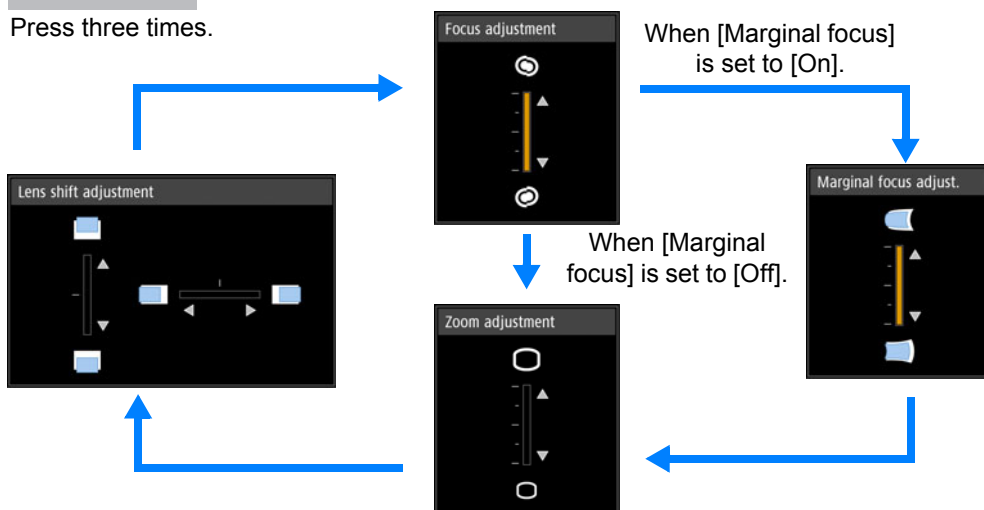

2 Press the pointer buttons to adjust.

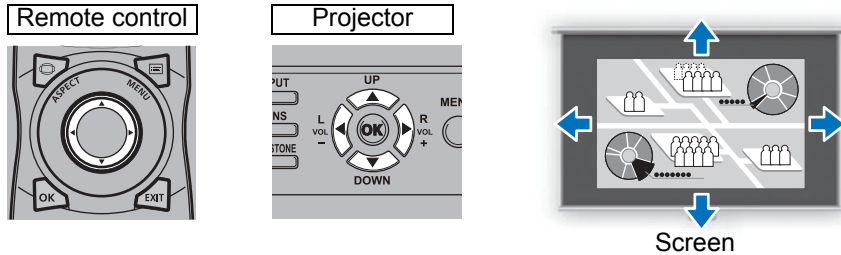

To raise or lower the image, use the [▲] / [▼] buttons on the remote control or projector.

To move the image left or right, use the [◀] / [▶] buttons on the remote control or projector.

To continue moving the image in a specific direction, hold down the corresponding button.

3 When the desired position is reached, press the OK button.

Resetting the Position

The lens position after movement with the lens shift function is not returned when the power is turned off. To return it to its original position, perform reset.

During screen position adjustment, press and hold the **SHIFT** button on the remote control or the **LENS** button on the projector to display the [Lens shift reset] window. Three options are available: +50%, -50%, 0% (home position). Use the pointer buttons to select an option, and then press the **OK** button.

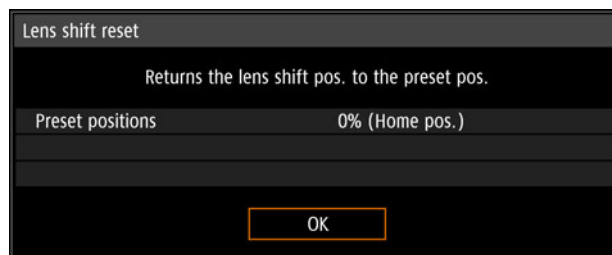

- The lens position may be reset slightly misaligned from the position you chose (+50%, -50%, 0% (home position)).
- For precise positioning, use the lens shift function to fine-tune the position.

Step 4 Select an Aspect Ratio (Screen Aspect) Matching the Screen

Select an optimum screen mode (aspect) according to the aspect ratio of the screen, type of input image signal and so on for the projection to make best use of the screen size.

Select the Aspect

Select [Aspect] based on the input signal type, aspect ratio of the screen and resolution.

Types of Aspect Ratios

■ Auto

An image is projected as large as possible at the aspect ratio of the input signal. Select this mode for normal image projection.

■ True size

The image is projected with the original resolution of the input signal. Screens of computers with a lower display resolution than the projector are displayed smaller but clearer than in other aspect ratios.



There may be some cases when this cannot be selected, depending on the input signal and/or resolution.

Selecting an Aspect Ratio

Press the **ASPECT** button on the remote control and select an appropriate aspect ratio. Press the **ASPECT** button to change the aspect ratio type.

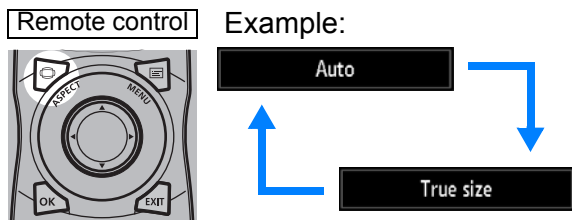

You can also select any aspect ratio from [Aspect] in the menu. (P93)

Step 5 Adjusting Keystone Distortion

To correct keystone distortion (Keystone adjustment), press the **KEYSTONE** button.

Two types of adjustment are available: horizontal/vertical adjustment and corner adjustment.

Use horizontal/vertical keystone adjustment to adjust image width or height distortion separately, and use corner adjustment to adjust the position of each corner of the image.

For instructions on switching keystone adjustment, refer to “Keystone” (P107).



- Keystone correction may not be effective in some lens shift positions.
- If keystone distortion is excessive and cannot be fully corrected, straighten the projector so that it faces the screen directly.
- Signals are processed digitally when keystone distortion is corrected. The image may look different from the original one. In addition, the aspect ratio of the image may change.

■ Horizontal/Vertical Keystone Adjustment

- 1 Press the **KEYSTONE** button on the remote control or projector to display the horizontal-vertical keystone adjustment window. (When [Keystone] is set to [Horizontal-vertical keystone].)

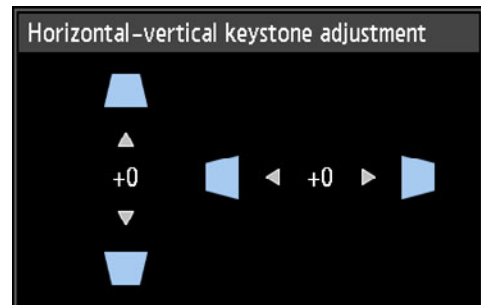
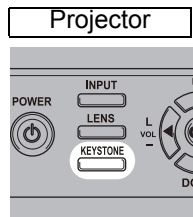
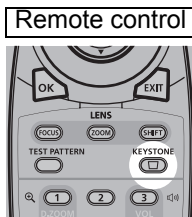

2 Press the pointer buttons to adjust the dimensions.

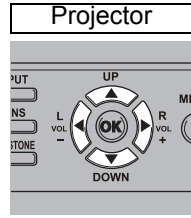
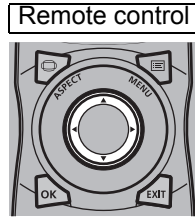

To correct top distortion, press the [▲] button.

To correct bottom distortion, press the [▼] button.

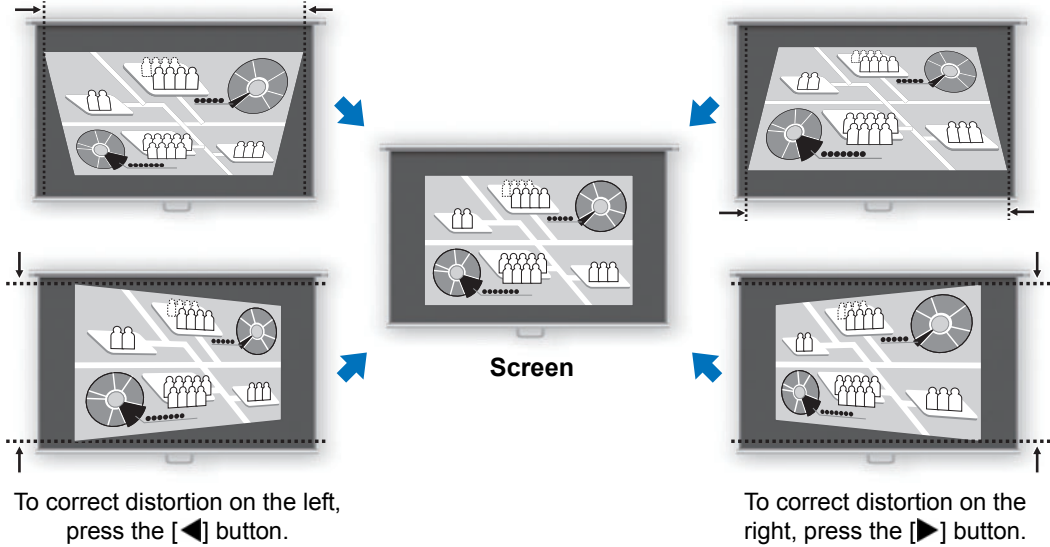

To correct distortion on the left, press the [◀] button.

To correct distortion on the right, press the [▶] button.

3 When keystone distortion has been corrected, press the OK button.

■ Corner Adjustment

1 Press the KEYSTONE button on the remote control or projector to display the corner adjustment window. (When [Keystone] is set to [Corner adjustment].)

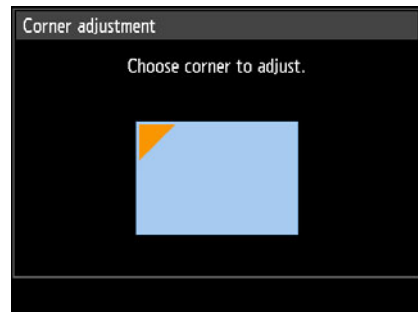
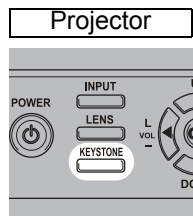
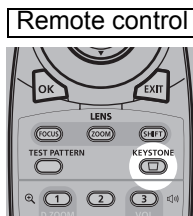

- Press the pointer button of the corner for correction, and then press the OK button.

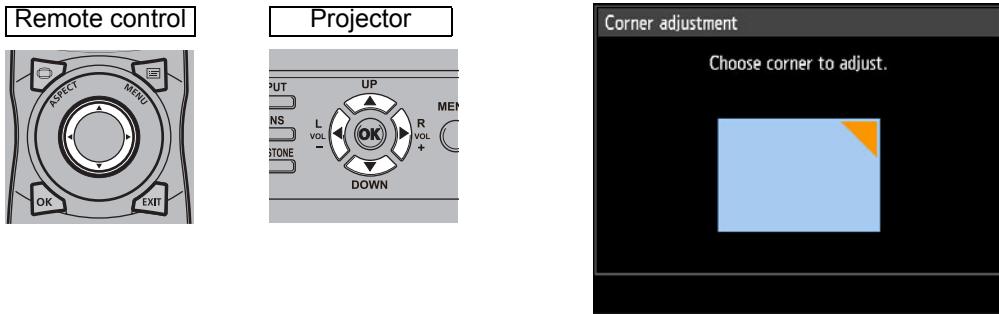

- Press the pointer buttons to adjust the corner.

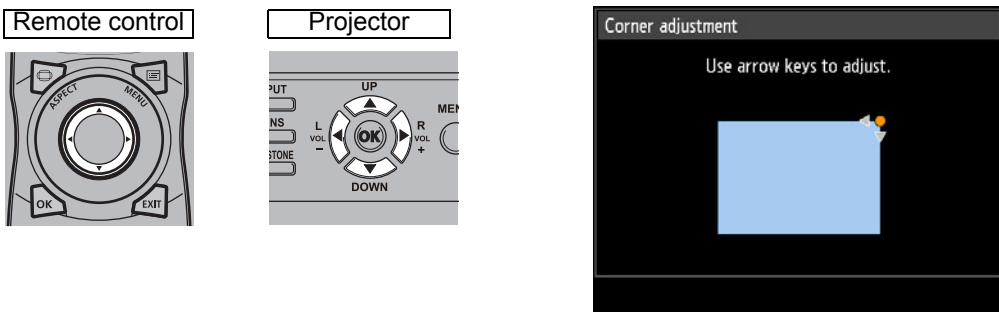

- When you have finished correcting, press the OK button.

■ Resetting the Keystone Adjustment

Reset adjustment as follows.

First, press the **KEYSTONE** button on the remote control twice to display the [Keystone reset] window.

Next, select [OK] with the [◀] button, and then press the **OK** button.

Your specified keystone adjustment is now reset.

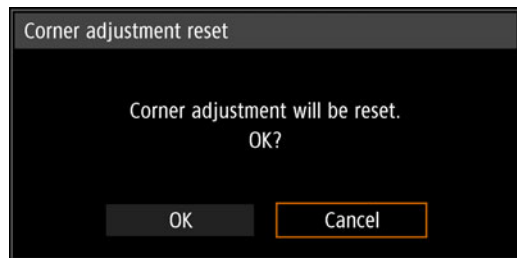
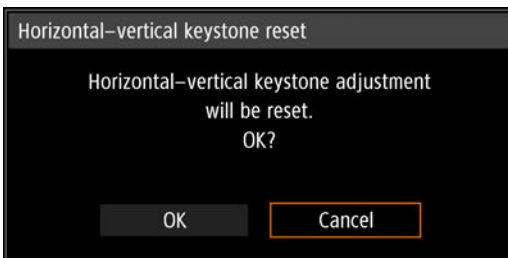

Step 6 Select the Image Quality (Image Mode)

You can select an image mode to suit the projected image.

In each image mode, you can further adjust the brightness, contrast, sharpness, gamma, HDR range, color adjustment (P100), advanced adjustment (P100), light source mode (P104) and brightness level. (P104)

Image Modes

Available image modes vary depending on the selected input signal.

○: Compatible —: Not compatible

| Image mode | Compatible input signals | | Functions (1) Ambient Brightness (2) Types of Images (3) Image Mode Characteristics |
|--------------|--------------------------|------|--|
| | Digital PC | HDMI | |
| Standard | ○ | ○ | (1) Bright (2) Computer screens, or media played with video software (3) Whites and natural colors |
| Presentation | ○ | ○ | (1) Bright (2) Images mainly consisting of text (3) Keeps the screen bright |
| Dynamic | — | ○ | (1) Bright (2) Media played with video software (3) Keeps the screen bright |
| Video | — | ○ | (1) Somewhat dark (2) Video from camcorders (3) Close to the color space of TVs |
| Photo/sRGB | ○ | ○ | (1) Somewhat dark (2) Digital images from sRGB-compatible cameras (3) Conforms to the sRGB standard |
| DICOM SIM | ○ | ○ | (1) Somewhat dark (2) Monochrome images (medical use, for example) (3) Adjusted to the GSDF curve specified in DICOM Standard Part 14 |
| User 1 – 3 | ○ | ○ | Up to 3 user-selected combinations of image quality settings can be stored in the memory (P99). Stored profiles are selected as image modes. |

■ Selecting an Image Mode

Press the **IMAGE** button on the remote control to select.

The image mode changes each time the **IMAGE** button is pressed. (The displayed image modes vary depending on the selected input signal.)

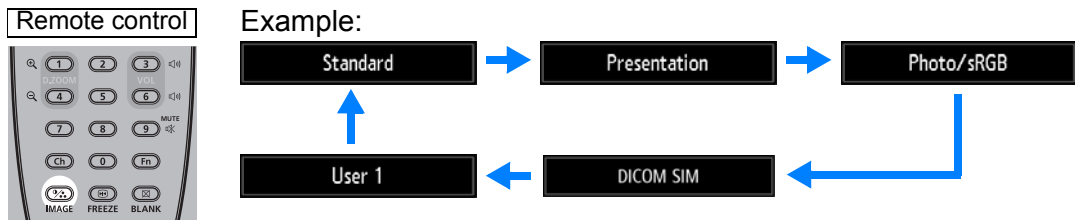

You can also select any image mode from the [Image mode] menu. (P98)

- User settings 1 - 3 are displayed when the desired image settings have been created and stored using the user memory function in the image adjustment menu. (P98)

Projecting an Image in the DICOM SIM Mode

In the DICOM simulation mode (hereinafter referred to as “DICOM SIM”), this projector can project a monochrome medical image such as an X ray radiography, CT image, MRI image, etc. in the tone similar to the DICOM (Digital Imaging and Communications in Medicine) standard. Typically, to project the image according to the DICOM standard, it requires the grayscale tone correction using a luminance meter according to the environment. In this projector, there are 21 types of tone settings for various ambient lights. You can correct the tone in a simplified manner by selecting the DICOM test pattern (P197).

It is suited to project an image in a medical lecture, academic conference, in-hospital conference, etc.

This projector is not the display monitor for a medical image. It cannot be used for the radiological image reading or medical examination.



Caution

- It is recommended to check the tone everytime when using this projector since it does not have the tone correction and calibration functions against the secular change.
- It may take approximately 30 minutes until the projection brightness of this projector becomes stabled.

■ Switching the mode to the DICOM SIM Mode

- 1 Press the **IMAGE** button on the remote control until **[DICOM SIM]** is displayed or select **[DICOM SIM]** from **[Image mode]** in the **[Image adjustment]** menu.

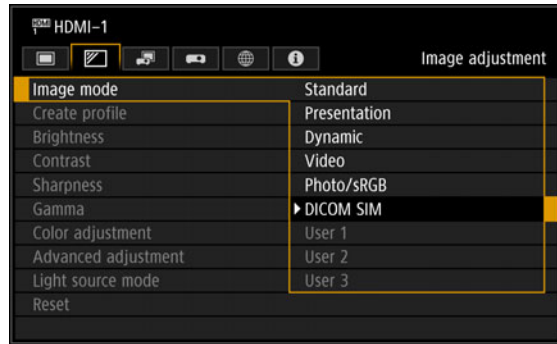

- 2 Display test patterns by pressing the **TEST PATTERN** button on the remote control or selecting **[On]** in **[Test pattern]** of the **[Install settings]** menu. Press the **[▲]** / **[▼]** buttons to select the **DICOM** test pattern.



- 3 As you view the test pattern, perform **[Gamma]** adjustment from the **[Image adjustment]** menu (**P99**) until the image is optimal.
- 4 Press the **OK** button after the setting.



Perform one of the followings to obtain an appropriate projection:

- Darken the ambient light
- Reduce the image size
- Reduce the projection distance

Step 7 Turn the Projector Off

- 1 Press the **POWER** button to display the window shown below.

Remote control

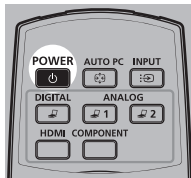

Projector

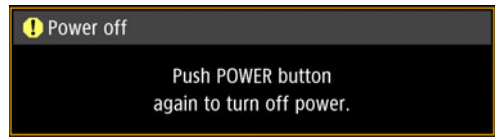
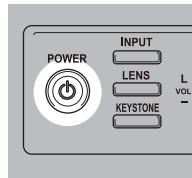

- 2 When this window is displayed, press the **POWER** button again to turn off the power.

After you turn the projector off, projection stops, the [STAND BY] indicator flashes in red, and the projector starts cooling down. After cooling down, the projector enters standby mode. In standby mode, the [STAND BY] indicator remains lit instead of flashing.

If you want to continue projecting without turning off the power, press a button other than **POWER**, or else wait until the confirmation message disappears.



- The projector cannot be turned on while cooling down.
- Using the projector for extended periods may shorten the life of the internal optical components.
- Unplug the projector if it will not be used for an extended period.

Convenient Features

This section describes features convenient during presentations and in other situations.

Temporarily Blacking Out an Image

Projection can be temporarily blanked after a presentation, or to divert the audience's attention away from the screen.



Press the **BLANK** button to black out the image.
Press the **BLANK** button again to show the image.

- You can set the screen state while blanking out the image in the menu. (P118)

Freezing the Picture

Projection can be temporarily frozen during computer operations that would be distracting, or to pause playback of video or animation.

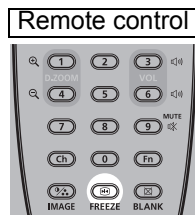

Press the **FREEZE** button to freeze the moving image. The projector shows the following icon.
Press the **FREEZE** button again to return to the original display.

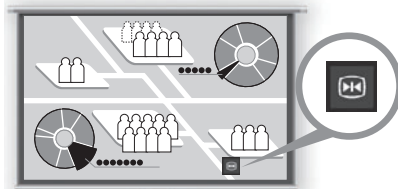

Screen

- It is also cancelled when the input signal is terminated.

Projecting a Test Pattern

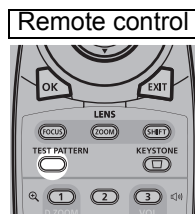

Even without any input signals, the projector can project a test pattern. Test patterns can be projected during installation to check how the projector is installed.

To project a test pattern, press the **TEST PATTERN** button on the remote control.

To stop test pattern projection, press the **TEST PATTERN** button again.

For details on projecting test patterns, see “Install settings” (P106) or “Displayed Test Patterns” (P197).

Specifying Power-Saving Settings

Set power-saving settings as needed.

The following four settings are available. For details, refer to the page describing each function.

- **Light source mode (P104)**
Conserve energy by selecting a mode that is less bright.
- **Power management mode (P124)**
Automatically turns off the light source or the power after a certain period if the projector is idle without an input signal.
- **Power management duration (P125)**
Specify the period after which the light source or projector should go off automatically if left idle without an input signal when [Power management mode] is set to [Light source off] or [Standby].
- **Standby power settings (P124)**
Conserves energy in standby mode by disabling some network functions.

Advanced Guide

Safety Instructions

Before Use

Installation Procedure

Connection Procedure

Projection Procedure

Convenient Features

Using Menus

Menu Configuration

Menu Settings

Using the Projector on a Network

Advanced Projection

Maintenance

Product Specifications

Troubleshooting

Basic Guide

Advanced Guide

Other Information

Using Menus

Use the menus to set the operation of the projector in detail.

Menu Configuration

The menu screen is divided into 6 tabs as shown below.

 **[Input settings] tab (P92)**
You can set the type of signal or the method of projection of the images input.

 **[Image adjustment] tab (P97)**
You can adjust the image quality and colors according to your preference.

 **[Install settings] tab (P106)**
This setting is used when installing the projector.

 **[System settings] tab (P117)**
You can set the operation of the projector.

 **[Network settings] tab (P135)**
These settings are for when using the projector from a PC via a network.

 **[Information] tab (P155)**
You can check information about the signal types of the images projected and other information.



Contents of menu

Menu items

Basic Menu Operations

- 1** Press the MENU button to display the menu window.

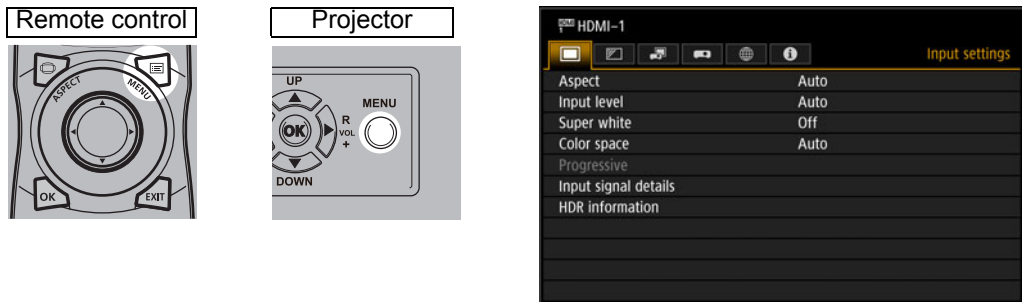

- 2** Press the [◀] / [▶] buttons to select a tab.

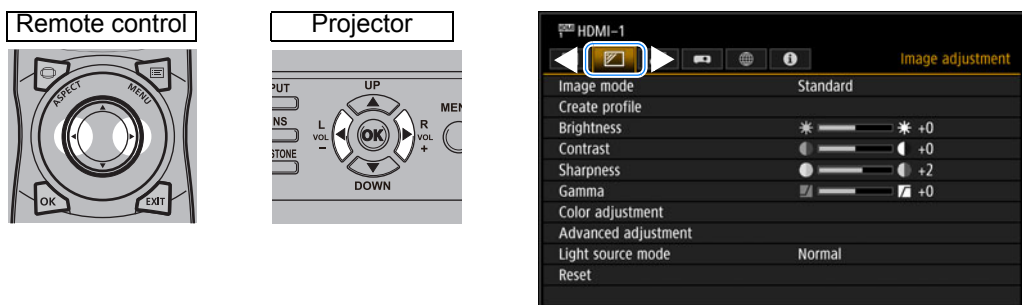

- If the tab position is not highlighted in orange, press the [▲] / [▼] buttons to move the current selection to the top.

- 3** Press the [▲] / [▼] buttons to select an item.

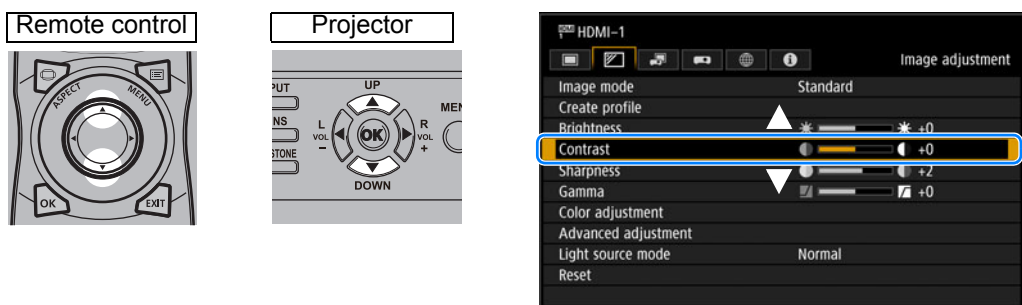

4 Select contents.

How to select the contents varies depending on the item.

Selecting from a list Example: Aspect (P93)

1. Select [Aspect].
2. Press the **OK** button or [▶] button to display a list of the contents.
3. Use the [▲] / [▼] buttons to select the desired contents.
4. When you have found the contents you desired, press the **OK** button or [▶].

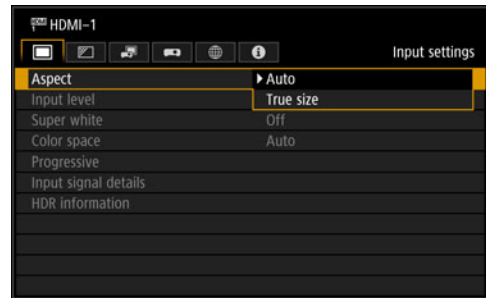

Adjusting with the [◀] / [▶] buttons Example: Contrast (P99)

1. Select [Contrast].
2. Use the [◀] / [▶] buttons to adjust the setting.

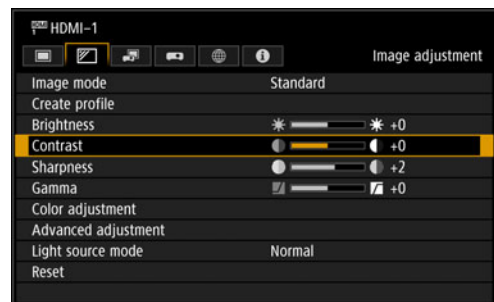

Selecting from a different screen (1) Example: Register network password (P141)

1. Select [Register network password].
2. Press the **OK** button to display a different screen.
3. Use the [▲] / [▶] / [▼] / [◀] buttons or number buttons on the remote control to enter the projector network password.



Selecting from a different screen (2) Example: Random noise reduction (P101)

1. Select [Advanced adjustment].
2. Press the **OK** button to display a different screen.
3. Select [Random noise reduction].
4. Use the [▲] / [▼] buttons to select the setting.
5. When you have completed the settings, press the **OK** button.

| Advanced adjustment | |
|------------------------|-----|
| Ambient light | Off |
| Random noise reduction | Off |
| MPEG noise reduction | Off |
| Dynamic gamma | Off |
| Dynamic contrast | Off |
| Mem. color correct | |
| 6-axis color adjust | Off |
| Fine-Tune Gamma | |
| Return | |

- 5** Pressing the **MENU** button causes the menu screen to disappear. The menu screen will also disappear if the **EXIT** button is pressed.

Menu Configuration

Input settings (P92)

| | | |
|----------------------|---------------------------------|-----|
| Aspect | Auto* | P93 |
| | True size | |
| Input level | HDMI | P93 |
| | Auto* | |
| | Normal | |
| | Expanded | |
| Super white | HDMI | P93 |
| | Off | |
| | On* | |
| Color space | HDMI | P94 |
| | Auto* | |
| | RGB | |
| | YCbCr | |
| Progressive | HDMI | P94 |
| | Off | |
| | Film/auto* | |
| | Video 1 | |
| | Video 2 | |
| | 25p/30p(PsF) | |
| Input signal details | Input signal | P95 |
| HDR information | HDMI | P96 |
| | EOTF | |
| | Display primaries [0] | |
| | Display primaries [1] | |
| | Display primaries [2] | |
| | White point | |
| | Max display mastering luminance | |
| | Min display mastering luminance | |
| | Max content light level | |
| | Max frame-average light level | |

Image adjustment (P97)

| | | |
|------------|---------------|-----|
| Image mode | Common | P98 |
| | Standard* | |
| | Presentation | |
| | Photo/sRGB | |
| | DICOM SIM | |
| | User 1 - 3 | |
| | HDMI | |
| | Dynamic | |
| | Video | |

* Factory default, or state after [Factory defaults] is executed.

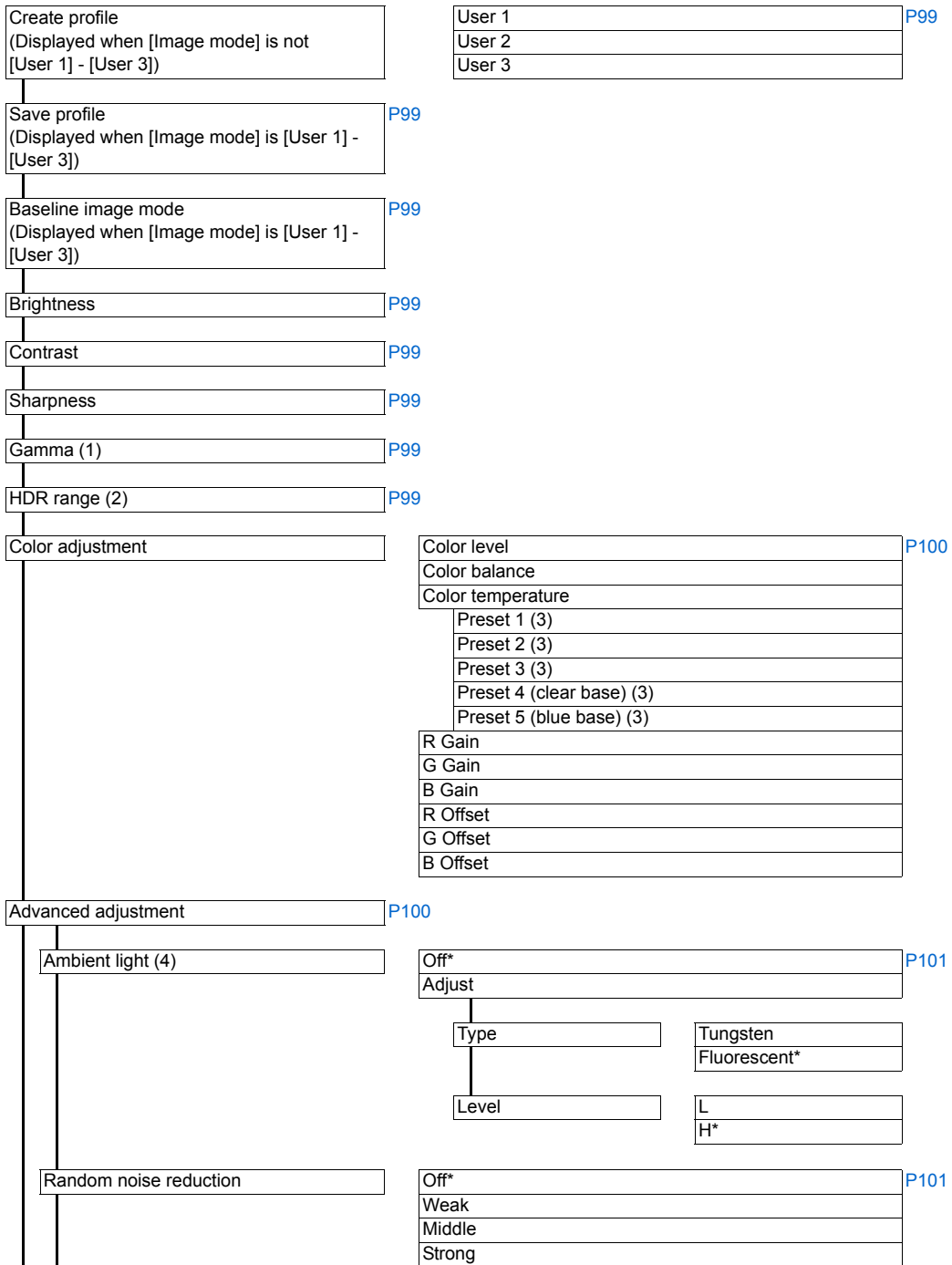

* Factory default, or state after [Factory defaults] is executed.

- (1) When [HDR range] does not appear in the menu
- (2) When image mode is [Video] and HDR is [On], or when image mode is [Video] and HDR is [Auto] and HDR signals are supplied
- (3) In [DICOM SIM] image mode
- (4) In [Photo/sRGB] image mode

Menu Configuration

| | | | |
|----------------------|--|-----------------------------------|------|
| MPEG noise reduction | Off* Weak Middle Strong | P101 | |
| Dynamic gamma | Off*1 Weak Middle Strong | P102 | |
| Dynamic contrast | Off* Mode 1 Mode 2 Mode 3 | P102 | |
| Colorimetry (1) | Auto* BT.709 BT.2020 | P102 | |
| HDR | Auto* Off On | P102 | |
| Mem. color correct | Flesh Sky Green | Off*2 Weak Middle Strong | P103 |
| 6-axis color adjust | Off* Adjust Hue Saturation Brightness Reset | P103 | |
| Fine-Tune Gamma (2) | | P104 | |
| Light source mode | Normal* Quiet 1 Quiet 2 Adjust Brightness level adjustment | P104 | |
| Brightness level (3) | | P105 | |
| Reset | | P105 | |

* Factory default, or state after [Factory defaults] is executed.

Under the following setting, differs from factory defaults.

- *1 [Weak] in [Dynamic] image mode with HDMI input.
- *2 [Weak] in [Dynamic]/[Video] image mode with HDMI input.
- (1) In [Video] image mode
- (2) When image mode is not [DICOM SIM] and [HDR range] does not appear in the menu
- (3) When the operating mode is not [Normal]

Install settings (P106)

| | | |
|-------------------------|--|------|
| Positional lock | Off* On | P107 |
| Image flip H/V | None* Ceiling mounted Rear Rear, Ceiling mounted | P107 |
| Keystone | Horizontal-vertical keystone* Corner adjustment Reset | P107 |
| Professional settings | | P108 |
| Panel drive mode | 4096x2160* 4096x2400 | P108 |
| Multi input mode select | DVI input mode Normal* Single DVI 1x2 DVI 2x2 DVI 1x4 HDMI input mode Normal* Single HDMI 1x2 | P108 |
| DVI optimizer | DVI dual link auto setting Off On* DVI-1 - 4 equalizer setting | P109 |
| HDMI EDID mode select | | P109 |
| HDMI-1 EDID mode | Wide bandwidth (4K60Hz)* High compatibility | |
| HDMI-2 EDID mode | Wide bandwidth (4K60Hz)* High compatibility | |
| RGB alignment | Micro-digital image shift Off* Adjust Registration Off* Adjust Advanced registration Off* Adjust 5-point adjustment Off* Adjust Manual adjustment Reset | P110 |

* Factory default, or state after [Factory defaults] is executed.

Menu Configuration

| | | |
|-----------------|--|------|
| High altitude | Off* On | P111 |
| Operating mode | Normal* Fixed brightness Long duration 1 Long duration 2 | P111 |
| Marginal focus | Off* On Reset | P112 |
| Edge blending | Off* Adjust Left Right Top Bottom Color blending adjustment Black level adjustment Marker Reset | P112 |
| Lens - Position | Load position 1 - 3 Save position 1 - 3 Lens shift reset | P115 |
| Screen color | Normal* Greenboard Adjust R/G/B Gain R/G/B Offset | P115 |
| Iris | Open* Close 1 - 3 | P116 |
| Test pattern | Off On | P116 |

System settings (P117)

| | | |
|----------------------|---|------|
| User screen settings | | P118 |
| Logo capture | | P118 |
| Logo position | Upper L Upper R Center* Lower L Lower R | P118 |
| No signal screen | Black Blue* User logo | P118 |



* Factory default, or state after [Factory defaults] is executed.

| | | |
|-----------------------------|---|------|
| Screen when blank | Black* Blue Light source off User logo | P118 |
| Projector on | Skip Canon logo* User logo | P118 |
| On screen | | P119 |
| Menu position | Upper L Upper R Center* Lower L Lower R | P119 |
| Menu display time | Normal* Extended | P119 |
| Menu rotation | Auto Off* 90 degrees counterclockwise 90 degrees clockwise | P120 |
| Guide | Off On* | P120 |
| Show input status | Off On* | P120 |
| Air filter warning display | Off On* | P120 |
| Overheat warning display | Off* On | P121 |
| Remote control/Side control | | P121 |
| Beep | Off On* | P121 |
| Key repeat | Off On* | P121 |
| Key lock | Off* Main unit Remote (wireless) | P121 |
| Remote control channel | Ch1 - 4 Independent* | P122 |

* Factory default, or state after [Factory defaults] is executed.

Menu Configuration

| | | |
|---------------------------|------------------|-------------------------------|
| Audio in terminal select | P123 | |
| DVI-1 | Off | Audio in* |
| DVI-2 | Off | Audio in* |
| DVI-3 | Off | Audio in* |
| DVI-4 | Off | Audio in* |
| HDMI-1 | Off | Audio in HDMI-1* |
| HDMI-2 | Off | Audio in HDMI-2* |
| DVI 1x2 | Off | Audio in* |
| DVI 2x2 / 1x4 | Off | Audio in* |
| HDMI 1x2 | Off | Audio in HDMI-1* HDMI-2 |
| Serial communication | Baud rate | P123 |
| | Data bits | |
| | Parity | |
| | Stop bit | 1* 2 |
| Power supply settings | P123 | |
| Standby power setting | Normal | P124 |
| | Low-power* | |
| Quick startup | Off* | P124 |
| | On | |
| Power management mode | Disabled | P124 |
| | Light source off | |
| | Standby* | |
| Power management duration | 5 min. | P125 |
| | 10 min. | |
| | 15 min.* | |
| | 20 min. | |
| | 30 min. | |
| | 60 min. | |
| Direct power on | Off* | P125 |
| | On | |

* Factory default, or state after [Factory defaults] is executed.

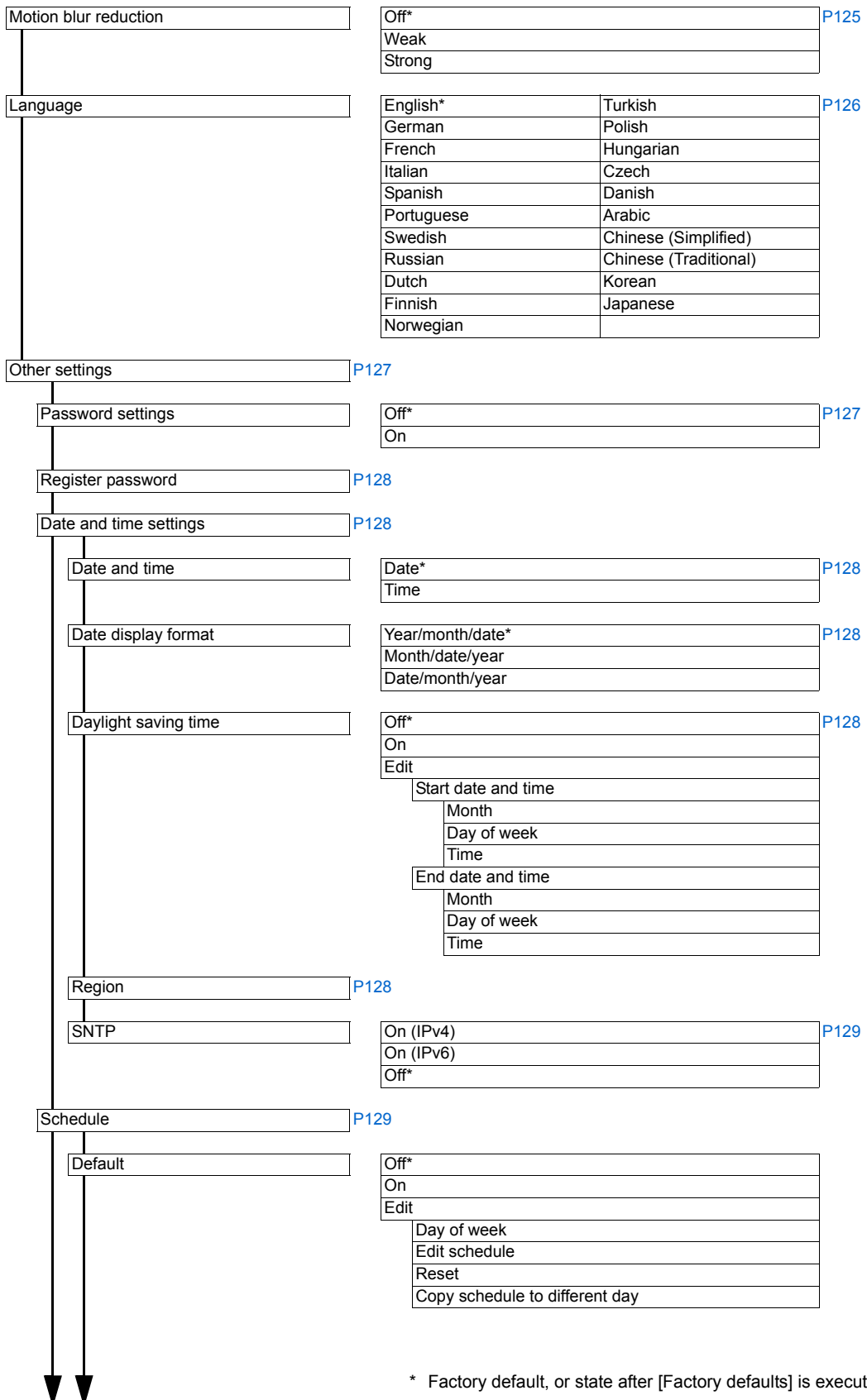

* Factory default, or state after [Factory defaults] is executed.

Menu Configuration

| | | |
|--------------------------|--------------------------------|------|
| Special period 1 | Off* | |
| | On | |
| | Edit | |
| | Period | |
| | Day of week | |
| | Edit schedule | |
| | Reset | |
| | Copy schedule to different day | |
| Special period 2 | Off* | |
| | On | |
| | Edit | |
| | Period | |
| | Day of week | |
| | Edit schedule | |
| | Reset | |
| | Copy schedule to different day | |
| Special period 3 | Off* | |
| | On | |
| | Edit | |
| | Period | |
| | Day of week | |
| | Edit schedule | |
| | Reset | |
| | Copy schedule to different day | |
| Special period 4 | Off* | |
| | On | |
| | Edit | |
| | Period | |
| | Day of week | |
| | Edit schedule | |
| | Reset | |
| | Copy schedule to different day | |
| Special period 5 | Off* | |
| | On | |
| | Edit | |
| | Period | |
| | Day of week | |
| | Edit schedule | |
| | Reset | |
| | Copy schedule to different day | |
| Calibration | P132 | |
| Gamma restore | Off* | P132 |
| | Adjust | |
| Adjust panel temperature | Off* | P133 |
| | Adjust | |
| Light source calibration | OK* / Cancel | P133 |
| Trigger out | Off* | P133 |
| | Link with power | |

* Factory default, or state after [Factory defaults] is executed.

| | | |
|--------------------|----------------|------|
| Air filter counter | Reset / Return | P133 |
| Power counter | | P133 |
| Firmware | Yes / No | P134 |
| Factory defaults | OK / Cancel | P134 |

Network settings (P135)

| | | |
|--------------------------------|---|------|
| Network settings lock | Unlock Lock* | P141 |
| Network password setting | Off On* | P141 |
| Register network password | | P141 |
| Network (wired/wireless) | Off/Off* On/Off On/On (Pj AP) Off/On (Pj AP) Off/On (Infra) | P142 |
| Detailed settings (wired) | | P142 |
| MAC address | | |
| Detailed IPv4 address settings | IP address Subnet mask Gateway address DHCP Off* On TCP/IP settings IP address Subnet mask Gateway address | |
| IPv6 | Off* On | |
| Detailed IPv6 address settings | Link local Auto Manual Gateway Auto settings Off* On Manual settings IP address Prefix length Gateway address | |
| Network setting initialization | Yes / No | |

* Factory default, or state after [Factory defaults] is executed.

Menu Configuration

| | |
|--------------------------------|---|
| Detailed settings (wireless) | P147 |
| Mode | |
| SSID | |
| Security | |
| Channel | |
| Signal strength | |
| MAC address | |
| Wi-Fi Protected Setup | PBC PIN |
| Manual settings | Mode SSID Security Open WEP WPA2 AES WPA / WPA2 TKIP / AES Channel Key ID Key type Key |
| Detailed IPv4 address settings | IP address Subnet mask Gateway address DHCP Off* On TCP/IP settings IP address Subnet mask Gateway address |
| IPv6 | Off* On |
| Detailed IPv6 address settings | Link local Auto Manual Gateway Auto settings Off On* Manual settings IP address Prefix length Gateway address |
| Network setting initialization | Yes / No |
| PJLink | Off On* P152 |

* Factory default, or state after [Factory defaults] is executed.

| | | |
|----------------------|---------------------------------|------|
| AMX Device Discovery | Off* | P153 |
| | On | |
| Crestron RoomView | Off* | P153 |
| | On | |
| Information | E-mail sender address | P154 |
| | E-mail recipient address | |
| | Detailed information (wired) | |
| | IPv4 | |
| | IPv6 | |
| | Link local | |
| | Auto | |
| | Manual | |
| | Detailed information (wireless) | |
| | IPv4 | |
| | IPv6 | |
| | Link local | |
| | Auto | |
| | Manual | |

Information (P155)

| |
|-----------------------|
| Model name |
| Input signal |
| Firmware |
| Serial no. |
| Projector usage time |
| IP address (wired) |
| IP address (wireless) |
| Projector name |
| Comments |
| System information ID |



The following settings are not reset even when factory defaults are restored.

- Selected input signal
- Image adjustment
 - Save profile
 - Baseline image mode
 - Light source mode
 - Brightness level
- Install settings
 - Lens - Position
- System settings
 - Registration
 - Advanced registration
 - High altitude
 - Operating mode
 - Marginal focus setting value
 - Remote control channel
- Serial communication (Stop bit)
- Standby power setting
- Quick startup
- Language
- Date and time settings
- Schedule
- Gamma restore
- Adjust panel temperature
- Trigger out
- Power counter
- Air filter counter
- Firmware
- Network settings
- Information

* Factory default, or state after [Factory defaults] is executed.

Menu Settings

Input settings

This section describes settings for aspect ratio, etc.



(When the input signal is HDMI-1)

| Menu | Function | Details |
|----------------------|--|---------------------|
| Aspect | Select an image aspect ratio. | P93 |
| Input level | Select the input level for HDMI signal. | P93 |
| Super white | Select super white mode for HDMI signal. | P93 |
| Color space | Select the color space for HDMI signal. | P94 |
| Progressive | Select the I/P conversion method used for interlaced signal input. | P94 |
| Input signal details | Shows input signal details for each input terminal used. | P95 |
| HDR information | Shows the Dynamic Range and Mastering InfoFrame for HDMI signals. | P96 |

Menus that are not available are grayed out or hidden.

Aspect



> [Input settings] > **[Aspect]**

Select a projection aspect ratio for images.

| Option | Function |
|-----------|--|
| Auto | An image is projected at the aspect ratio of the input signal. |
| True size | The image is projected with the original resolution of the input signal. |

Menus that are not available are hidden.



The **ASPECT** button on the remote control can also be used to select the [Aspect] settings.

Input level



> [Input settings] > **[Input level]**

Adjust the input level for content projected via HDMI.

| Option | Function |
|----------|---|
| Auto | Automatically switches the input level based on the input signal. |
| Normal | Limits the input level to 16 - 235. |
| Expanded | Enables a full input level of 0 - 255. |



- This setting is only available with RGB HDMI signals.
- In [Auto] mode, the signal level is selected automatically. (Some equipment may not support this.)
- If the HDMI output of the connected equipment can be set to [Normal] or [Expanded], we recommend [Expanded]. The contrast of images will be improved and dark scenes will be rendered more realistically. In this case, set the projector's [Input Level] to [Auto] or [Expanded].
For more detailed information, refer to the user's manual for the equipment connected to the projector.

Super white



> [Input settings] > **[Super white]**

Select to project white signals in HDMI input that are in a range of 16-235 at 100%-109% brightness (235-255).

| Option | Function |
|--------|--|
| Off | Disable super white. Project white signals with an input level of 235 at 100% brightness. All white signals with an input value exceeding 235 are also projected at 100% brightness. |
| On | Convert input signals in a range of 16-235 so that an input level of 255 is projected as white 109% at 100% brightness. |



- Super white has no effect when [Input level] is set to [Expanded].
- Switch this setting to [Off] if projection looks distorted or unnatural when it is [On].
- Setting this option to [On] will darken the overall image.

Color space



> [Input settings] > **[Color space]**

Select the color space for HDMI signal.

| Option | Function |
|--------|---|
| Auto | Selects the optimal color format for input signals. |
| RGB | Forces the projector to handle the input signal as an RGB signal. |
| YCbCr | Forces the projector to handle the input signal as a color difference signal. |

Progressive



> [Input settings] > **[Progressive]**

Performs progressive processing optimized for still images in cinematic content or moving images in videos, when interlaced HDMI signals are supplied.

| Option | Function |
|---------------|---|
| Off | Does not perform progressive processing. |
| Film/auto | Suitable for still images or typical moving images. Performs progressive processing optimized for video or cinematic content. |
| Video 1 | Suitable for projecting video with high image quality and relatively slow movement. Performs progressive processing optimized for HD video. |
| Video 2 | Suitable for projecting video with faster movement. Performs progressive processing optimized for fast-moving video. |
| 25p/30p (PsF) | Performs progressive processing optimized for 1080 Psf/25 or 1080 Psf/30 video (25 or 30 fps, respectively). |



Select [Off] when flickers and horizontal lines are noticeable in media that has a lot of fast-moving action.

Input signal details

 > [Input settings] > **[Input signal details]**

Shows input signal details for each input terminal used, for the selected input signals.



In Multi Input mode, terminals with incorrect input can be identified by a “” icon, which is displayed for input terminals with signals that do not meet the requirements.

- HDMI input

Indicates the resolution, vertical frequency, color format (for YCbCr, the color format and subsampling; for RGB, the color format and range), color depth, VIC, and colorimetry information.

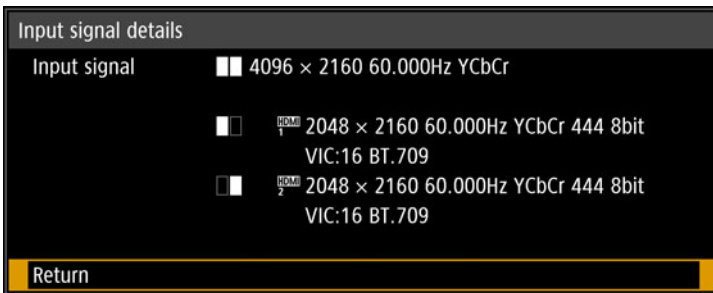

In the example above, the HDMI-1/2 input signal has a resolution of 2048 x 2160, a vertical frequency of 60.000 Hz, a color format of YCbCr/subsampling 444, and a color depth of 8 bits.

If no additional information from the input signal is displayed, it is marked with “*”.

- DVI input

Indicates the resolution and vertical frequency.

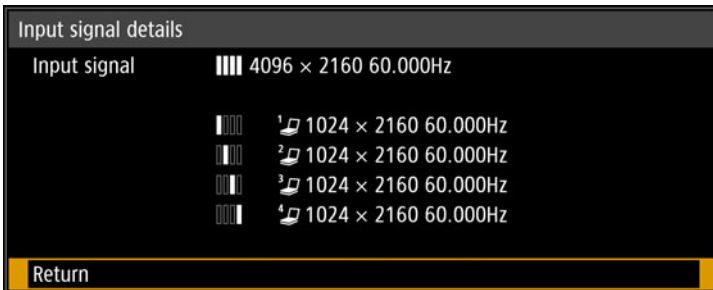

In the example above, the DVI-1/2/3/4 input signal has a resolution of 1024 x 2160, and a vertical frequency of 60.000 Hz.

HDR information

 > [Input settings] > **[HDR information]**

When HDMI signals are supplied, shows the Dynamic Range and Mastering InfoFrame information.

The projector determines and indicates whether HDMI signals are SDR or HDR. HDR HDMI signals have an area that includes color and luminance information, and this information is indicated. The following information is displayed.

| HDR Information | | |
|---------------------------------|--------------------------|----------|
| EOTF | Traditional gamma-SDR | |
| Display primaries[0] | x:0.2650 | y:0.6900 |
| Display primaries[1] | x:0.1500 | y:0.0600 |
| Display primaries[2] | x:0.6800 | y:0.3200 |
| White point | x:0.3127 | y:0.3290 |
| Max display mastering luminance | 4000 cd/m ² | |
| Min display mastering luminance | 0.0050 cd/m ² | |
| Max content light level | 1500 cd/m ² | |
| Max frame-average light level | 300 cd/m ² | |
| Return | | |

| Item | Information Indicated | Details | |
|---------------------------------|--|--|--|
| EOTF | Traditional gamma-SDR | SDR signal | Indicates various gamma information of the video content |
| | SMPTE ST 2084 | HDR signal | |
| Display primaries [0],[1],[2] | x: 0.00002 – 1.00000 y: 0.00002 – 1.00000 | Coordinates of the three vertices of the gamut triangle in the color space | |
| White point | x: 0.00002 – 1.00000 y: 0.00002 – 1.00000 | Coordinates of “white” in the color space | |
| Max display mastering luminance | 1 – 65535 cd/m ² | Maximum luminance of the display used when the video content was produced | |
| Min display mastering luminance | 0.0001 – 6.5535 cd/m ² | Minimum luminance of the display used when the video content was produced | |
| Max content light level | 1 – 65535 cd/m ² | Maximum luminance of scenes in the video content | |
| Max frame-average light level | 1 – 65535 cd/m ² | Average luminance of scenes in the video content | |

Image adjustment

This section describes image quality settings such as brightness, contrast, and sharpness.

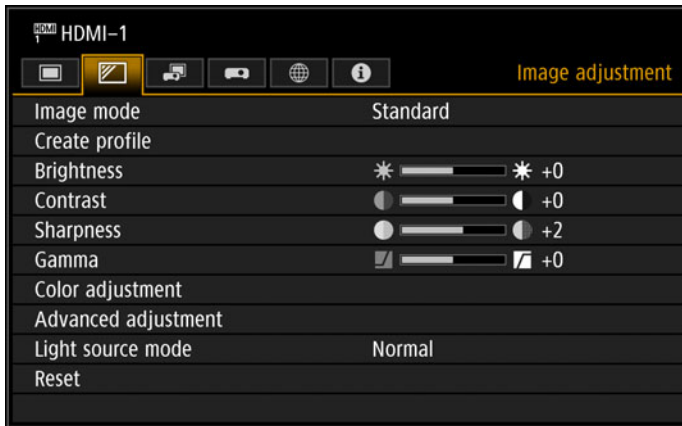

(When the input signal is HDMI-1)

| Menu | Function | Details |
|-----------------------|---|----------------------|
| Image mode * | Select overall image quality to suit the projected image. | P98 |
| Create profile | Save desired image quality settings as profiles. | P99 |
| Baseline image mode | Only displayed when the image mode is set to a profile from [User 1] to [User 3]. Shows the image mode that was modified to create the profile. | P99 |
| Brightness * | Adjust image brightness. | P99 |
| Contrast * | Adjust image contrast. | P99 |
| Sharpness * | Adjust image sharpness. | P99 |
| Gamma * | Correct loss of detail in shadows or highlights. | P99 |
| HDR range * | Within the dynamic range of SMPTE ST 2084, set the range to use. | P99 |
| Color adjustment * | Fine-tune image colors. | P100 |
| Advanced adjustment * | Fine-tune noise reduction and color tone. | P100 |
| Light source mode * | Adjust projection brightness and operating sounds. | P104 |
| Brightness level * | Adjust projection brightness as controlled by the drive current of the laser diode. | P105 |
| Reset | Restore the current image quality settings to defaults. | P105 |

Menus that are not available are grayed out or hidden.

* Adjustments are stored as modified settings for the current input signal and image mode.

Image mode



> [Image adjustment] > **[Image mode]**

Select the overall image quality for projected images. Can also be selected by pressing the **IMAGE** button on the remote control.

| Option | Types of Images | Characteristics |
|--------------|---|---|
| Standard | Computer screens, or media played with video software | Bright overall; white, with natural colors |
| Presentation | Images mainly consisting of text | Bright overall |
| Dynamic | Video content | Bright overall |
| Video | Video from camcorders | Somewhat dark; colors resemble TV |
| Photo/sRGB | Digital images from sRGB-compatible cameras | Somewhat dark; conforms to the sRGB standard |
| DICOM SIM | Medical or other monochrome images | Conforms to DICOM Standard Part 14. However, the projector cannot be used in diagnosis or similar applications. |
| User 1 - 3 | Up to 3 user profiles can be stored for your selected image quality settings. Stored profiles are available in this setting as an image mode. | |

Menus that are not available are grayed out or hidden.



- You can adjust the image quality by adjusting the following items in each image mode: [Brightness], [Contrast], [Sharpness], [Gamma], [HDR range], [Color adjustment], [Advanced adjustment], [Light source mode], and [Brightness level]
- If flickering occurs when the image mode is set to [Presentation], try switching to [Photo/sRGB] or [Standard].

Create profile

 > [Image adjustment] > **[Create profile]**

Save desired image quality settings in up to 3 user profiles.



- The saved settings are [Brightness], [Contrast], [Sharpness], [Gamma], [HDR range], [Color adjustment], [Advanced adjustment], [Light source mode], and [Brightness level].
- Although only 3 user profiles are displayed, separate profiles apply depending on whether DVI-D or HDMI signals are supplied. As a result, it is possible to save up to 6 settings.
- The image mode name which was the basis for the settings change is also saved in the user memory. When a user memory is selected as the image mode, the image mode that was the base for that user memory is displayed in the menu as [Baseline image mode].

Brightness

 > [Image adjustment] > **[Brightness]**

Adjust image brightness.

Contrast

 > [Image adjustment] > **[Contrast]**

Sharpen or soften image contrast.

Sharpness

 > [Image adjustment] > **[Sharpness]**

Adjust image sharpness.

Gamma

 > [Image adjustment] > **[Gamma]**

Correct image areas that are too dark or too bright to see clearly.



For more detailed adjustment, use Fine-Tune Gamma ([P104](#)).

HDR range

 > [Image adjustment] > **[HDR range]**

Within the dynamic range of SMPTE ST 2084, set the range to use.

[Gamma] is not shown when the menu includes [HDR range].



[HDR range] can only be set in the following cases.

- Image mode ([P98](#)) is set to [Video] and HDR ([P102](#)) is [On]
- Image mode ([P98](#)) is set to [Video], HDR ([P102](#)) is [Auto], and HDR signals are supplied

Color adjustment

 > [Image adjustment] > **[Color adjustment]**

Adjust color-related settings such as color level, color balance, and color temperature.

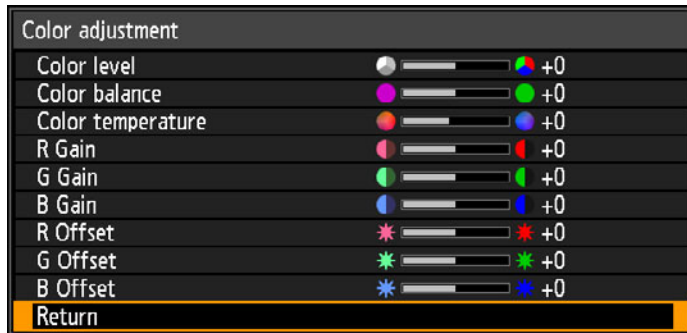

(In image modes other than DICOM SIM.)

| Submenu | Function |
|-------------------|--|
| Color level | Adjusts the intensity of colors. |
| Color balance | Adjusts the color balance of a purplish or greenish image. |
| Color temperature | Adjusts the white color temperature. |
| R / G / B Gain | Adjust the gain of each color. |
| R / G / B Offset | Adjusts the color offset of each color. |



In [DICOM SIM] image mode, [Color temperature] is not adjusted with numeric values but set to one of the following five presets.

Preset 1: Prioritize brightness, relative to DICOM Standard Part 14.

Preset 2: Prioritize color tone, relative to DICOM Standard Part 14.

Preset 3: Adjust color to conform to DICOM Standard Part 14.

Preset 4: Reproduce colors of X-ray film (Clear base).



Preset 5: Reproduce colors of X-ray film (Blue base).

Advanced adjustment

 > [Image adjustment] > **[Advanced adjustment]**

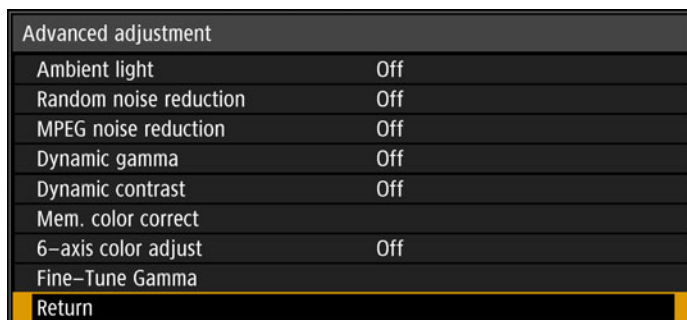
Fine-tune noise reduction and color tone.



| Ambient light | | | |
|---|---|--------------------|---|
| Minimize the effect of ambient light on the screen. | | | |
| Submenu | Function | | |
| Off | No correction is performed. | | |
| Adjust | Type | Tungsten | For ambient light from conventional light bulbs or fluorescent light of this color. |
| | | Fluorescent | For ambient light from a “day white” fluorescent source. |
| | Level | L | For an ordinary brightness of ambient light. |
| | | H | For bright ambient light. |
| Examples of Ambient Light Level Settings | | | |
| Level | Example Location | | |
| L | Projection room, sports bar, etc. | | |
| H | Conference room, lecture room, etc. | | |
|  <ul style="list-style-type: none"> • This setting is available when the image mode is set to [Photo/sRGB]. • This setting is available when the baseline image mode is set to [Photo/sRGB]. | | | |
| Random noise reduction | | | |
| Reduce image noise associated with random frequencies and amplitudes. | | | |
| Option | Function | | |
| Off | Disables random noise reduction. | | |
| Weak | Specify one of three levels of intensity of the random noise reduction. | | |
| Middle | | | |
| Strong | | | |
|  Select [Weak] for fast-moving images or [Strong] for slow-moving images. | | | |
| MPEG noise reduction | | | |
| Reduce MPEG image noise. | | | |
| Option | Function | | |
| Off | Disables MPEG noise reduction. | | |
| Weak | Specify one of three levels of intensity of the MPEG noise reduction. | | |
| Middle | | | |
| Strong | | | |

Dynamic gamma

You can adjust the gradation representation of light and dark portions of an image automatically.

| Option | Function |
|--------|--|
| Off | Disable dynamic gamma adjustment. |
| Weak | Specify one of three levels of dynamic gamma adjustment. |
| Middle | |
| Strong | |

Dynamic contrast

For dark images, makes dark image areas even darker.

| Option | Function |
|--------|---|
| Off | Disable dynamic contrast adjustment. |
| Mode 1 | Suitable for videos and slideshows. Enhances contrast slightly, and suits bright viewing environments. Contrast is adjusted automatically in response to changes in the input signal. |
| Mode 2 | Suitable for slideshows and videos with scenes that change gradually, as for landscapes. Enhances contrast, and suits dark viewing environments. Contrast is adjusted automatically in response to changes in the input signal. |
| Mode 3 | Suitable for videos with many scene changes. Enhances contrast, and suits dark viewing environments. Contrast is adjusted automatically and more aggressively in response to changes in the input signal. |

Colorimetry

Select the input color space.

| Option | Function |
|---------|---|
| Auto | Automatically determine the optimal color space (BT.709 or BT.2020) based on input signals. |
| BT.709 | Forces use of the BT.709 color space. |
| BT.2020 | Forces use of the BT.2020 color space. |



[Colorimetry] can only be set when the image mode (P98) is [Video].

HDR (High Dynamic Range)

HDR range adjustment projects an expanded range of image luminance, preserving detail in highlights and shadows.

| Option | Function |
|--------|--|
| Auto | Automatically use HDR when HDR signals are supplied. |
| Off | Prevent use of HDR. |
| On | Require use of HDR. |



[HDR] can only be set when the image mode (P98) is [Video].

Mem. color correct (Flesh/Sky/Green)

Enhances skin tones, blue skies, and greens, so that these colors are more consistent with people's remembered impressions.

| Option | Function |
|--------|----------------------------------|
| Off | Disable correction. |
| Weak | Specify the level of correction. |
| Middle | |
| Strong | |



Image resolution may seem lower when [Random noise reduction] or [MPEG noise reduction] is applied.

6-axis color adjust

Fine-tune RGB (red, green, blue) and CMY (cyan, magenta, yellow) hues in images.

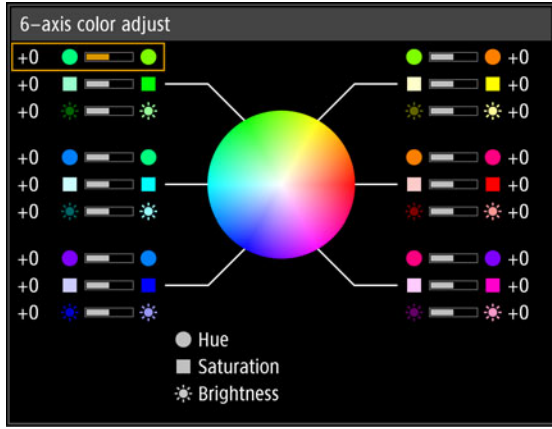
| Submenu | Function |
|---------|---|
| Off | Disables 6-axis color adjustment. |
| Adjust |  <p>Use the [▲] / [▼] buttons to select [○ Hue], [□ Saturation], or [★ Brightness], and use the [◀] / [▶] buttons for adjustment.</p> |
| Reset | Returns all adjustment values to zero. |

Fine-Tune Gamma

Adjust white, red, green, and blue gamma curves. Red, green, and blue can be adjusted separately. Adjustments to white are also applied to the three other colors. Note that adjusting any color will overwrite previous adjustments.

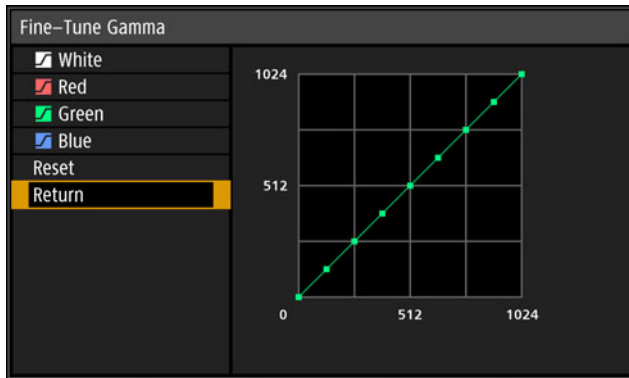

Use the [▲] / [▼] buttons to select a color, and then press the **OK** button. Next, use the [◀] / [▶] buttons to select an adjustment point and the [▲] / [▼] buttons for adjustment.





- [Fine-Tune Gamma] is available in image modes other than [DICOM SIM], and when [HDR range] does not appear in the menu.
- For details on gamma correction, see [page 99](#).
- Use input signals or a test pattern for adjustment.

Light source mode

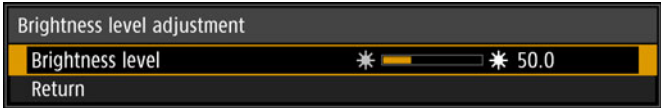

> [Image adjustment] > **[Light source mode]**

Reducing projection brightness reduces power consumption and fan noise.

| Option | Function |
|---------|---|
| Normal | Projects images at full brightness. |
| Quiet 1 | Select to reduce brightness, or when quiet projection is required. |
| Quiet 2 | Reduces brightness and noise further. |
| Adjust | <p>Based on your specified brightness, fan speed is adjusted automatically. Use the [◀] / [▶] buttons to adjust the brightness on the Brightness level adjustment screen that appears.</p>  <p> [Brightness level] is shown when the light source mode is set to [Adjust].</p> |



[Light source mode] is displayed when the operating mode is [Normal]. If the operating mode ([P111](#)) is not set to [Normal], [Brightness level] appears instead of [Light source mode].

Brightness level

 > [Image adjustment] > **[Brightness level]**

Control the laser diode to adjust the projection brightness.
Use the [◀] / [▶] buttons to adjust the brightness.



[Brightness level] appears instead of [Light source mode] when the operating mode (P111) is not set to [Normal].

Reset

 > [Image adjustment] > **[Reset]**

Restore the current image quality settings to defaults.

| Option | Function |
|--------|---|
| OK | Resets the image adjustment settings. |
| Cancel | Cancels resetting of the image adjustment settings. |



- Performing reset when [Image mode] is set to a profile from [User 1] to [User 3] will restore the settings originally saved for that user profile.
- Only the setting for the combination of input signal and image mode for the current projection is reset.
- The following settings are reset (initialized).
 - Brightness
 - Gamma
 - Color balance
 - R/G/B Offset
 - MPEG noise reduction
 - Colorimetry
 - 6-axis color adjust (Hue/Saturation/Brightness)
 - Brightness level
 - Contrast
 - HDR range
 - Color temperature
 - Ambient light (Type/Level)
 - Dynamic gamma
 - HDR
 - Fine-Tune Gamma (White/Red/Green/Blue)
 - Sharpness
 - Color level
 - R/G/B Gain
 - Random noise reduction
 - Dynamic contrast
 - Mem. color correct
 - Light source mode

Install settings

Adjust projection to suit the screen or the type of images, or how the projector is installed.

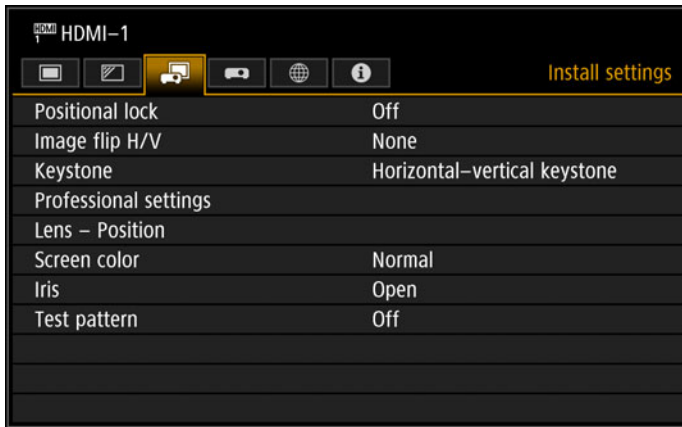

(When the input signal is HDMI-1)

| Menu | Function | Details |
|-----------------------|---|----------------------|
| Positional lock | Operation of installation related functions can be prohibited. | P107 |
| Image flip H/V | Specify settings for projection from behind the screen, from the ceiling, or both. | P107 |
| Keystone | Specify the type of keystone adjustment. | P107 |
| Professional settings | Specify advanced installation settings. | P108 |
| Lens - Position | Store information about the lens position (including focus, zoom, and lens shift settings), which can be used to restore the lens to these positions. | P115 |
| Screen color | Adjust projection colors to suit the screen color. | P115 |
| Iris | The aperture value can be adjusted in a range of 1-3. A smaller aperture reduces brightness but improves contrast. | P116 |
| Test pattern | Project a test pattern to check the resolution and color of projection during installation. | P116 |

Menus that are not available are grayed out.

Positional lock

 > [Install settings] > **[Positional lock]**

Operation of installation-related functions can be prohibited.

- Image flip H/V • Keystone • Professional settings • Lens - Position (Save position, Lens shift reset)

| Option | Function |
|--------|--|
| Off | Enables adjustment of installation-related functions. |
| On | Prevents adjustment of installation-related functions. |

Image flip H/V

 > [Install settings] > **[Image flip H/V]**

Specify the orientation of how the projector is installed.

| Option | Function |
|-----------------------|--|
| None | Select for normal projection, without inversion. |
| Ceiling mounted | Select when the projector is installed upside-down. The projected image is inverted in the vertical direction. |
| Rear | Select this to project an image from behind the screen. The projected image is inverted in the horizontal direction. |
| Rear, Ceiling mounted | Select when the projector is installed upside-down on the ceiling and behind the screen. The projected image is inverted in both vertical and horizontal directions. Select when the projector is installed upside-down. |



- When mounting the projector on a ceiling, use the optional ceiling attachment (RS-CL15) and ceiling-mount arm (RS-CL17). Contact the Canon Customer Support Center for more detailed information.
- Image flipping will reset any adjustment for keystone distortion. In this case, redo the adjustment.
- Adjusting the [Image flip H/V] setting does not alter button assignments in the projector's side controls.

Keystone

 > [Install settings] > **[Keystone]**

Specify either [Horizontal-vertical keystone] or [Corner adjustment] keystone adjustment. Keystone adjustment can also be reset. Keystone adjustment can also be applied by pressing the **KEYSTONE** button on the remote control.

| Option | Function |
|------------------------------|---|
| Horizontal-vertical keystone | Apply horizontal-vertical keystone adjustment. Image height and length is adjusted. |
| Corner adjustment | Apply corner adjustment. Each corner of the image can be repositioned. |
| Reset | Resets any adjustments to the keystone value. |

Professional settings

 > [Install settings] > **[Professional settings]**

Specify advanced installation settings.

| | |
|-------------------------|-----------|
| Professional settings | |
| Panel drive mode | 4096x2160 |
| Multi input mode select | |
| DVI optimizer | |
| HDMI EDID mode select | |
| RGB alignment | |
| High altitude | Off |
| Operating mode | Normal |
| Marginal focus | Off |
| Edge blending | Off |
| Return | |

Panel drive mode

Select the LCD panel vertical resolution to use.

| Option | Function |
|-----------|--|
| 4096x2160 | Use a resolution of 4096 x 2160 lines. |
| 4096x2400 | Use a resolution of 4096 x 2400 lines. |



- Select [4096x2400] only when a signal with a resolution of 4096 x 2400 is supplied.
- Changing the panel drive mode resets the following values.
 - Horizontal-vertical keystone
 - Corner adjustment
- Adjustment values stored for edge blending vary depending on the panel drive mode.

Multi input mode select

Select how to combine four DVI inputs or two HDMI inputs to form an image.

| Submenu | Option | Function |
|-----------------|----------|--|
| DVI input mode | Normal | For use with [Single], [DVI 1x2], [DVI 2x2], or [DVI 1x4] DVI input. |
| | Single | For use with a single terminal supplying DVI input. |
| | DVI 1x2 | For use with DVI input from two cables. |
| | DVI 2x2 | For use with DVI input from four cables, projected in a 2x2 layout. |
| | DVI 1x4 | For use with DVI input from four cables, projected side by side. |
| HDMI input mode | Normal | For use with [Single] or [HDMI 1x2] HDMI input. |
| | Single | For use with a single terminal supplying HDMI input. |
| | HDMI 1x2 | For use with HDMI input from two cables. |

DVI optimizer

Optimizes images from DVI signals.

| Submenu | Option | Function |
|----------------------------|---|--|
| DVI dual link auto setting | Off | Disable automatic determination of single- or dual-link mode from DVI terminals, and project images in single-link mode. |
| | On | Automatically determine whether DVI terminals are used in single- or dual-link mode and switch settings accordingly. |
| Option | Function | |
| DVI-1 equalizer setting | Adjust the equalizer value for DVI terminals. Choose lower values for higher amplification, or higher values for lower amplification. Example of equalizer settings <ul style="list-style-type: none"> • Decrease values to amplify signals that have been attenuated by a long cable. • Signals may be too strong if noise occurs when using a short cable, or when using an active cable, signal corrector, or repeater. If so, increase values to attenuate and correct the signals. | |
| DVI-2 equalizer setting | | |
| DVI-3 equalizer setting | | |
| DVI-4 equalizer setting | | |



- When a dual-link cable is used, any noise in the signal line may prevent normal projection. If this occurs, set [DVI dual link auto setting] to [Off].
- In some cases when DVI terminals are used, the cable may not be a good match for the projector, which may cause video noise or prevent the signal from being detected. If this occurs, adjust values in each setting from [DVI-1 equalizer setting] to [DVI-4 equalizer setting].

HDMI EDID mode select

Select an HDMI terminal (1 or 2) EDID that is compatible with connected equipment.

| Submenu | Function | |
|------------------|-------------------------|---|
| HDMI-1 EDID mode | Option | Function |
| | Wide bandwidth (4K60Hz) | Select when connected equipment can supply high-bandwidth signals such as 3840 x 2160 (4K) at 60 Hz, YCbCr 4:4:4. |
| HDMI-2 EDID mode | High compatibility | Select in case of incorrect video or audio output from the projector because the EDID is not read correctly by connected equipment when set to Wide bandwidth (4K60Hz). |



Even if this function is used, the list of supported video formats may not be updated when [HDMI input mode] in [Multi input mode select] is set to [HDMI 1x2].

RGB alignment

Correct color misalignment.

| Submenu | Function | | | | | | | | | | | | |
|---------------------------|--|---|----------|--------------------|---|--|--|--|----------|---|---|-------|---|
| Micro-digital image shift | Fine positioning enables adjustment of misalignment relative to images from other projectors used at the same time, in 1-pixel increments. | | | | | | | | | | | | |
| | <table border="1"> <thead> <tr> <th>Submenu</th> <th>Function</th> </tr> </thead> <tbody> <tr> <td>Off</td> <td>Disable micro-digital image shift.</td> </tr> <tr> <td rowspan="3">Adjust</td> <td> <table border="1"> <thead> <tr> <th>Submenu</th> <th>Function</th> </tr> </thead> <tbody> <tr> <td>Adjust</td> <td>Adjust the image vertically and horizontally.</td> </tr> <tr> <td>Chart</td> <td>Display a chart (point selection window).</td> </tr> </tbody> </table> </td> </tr> </tbody> </table> | Submenu | Function | Off | Disable micro-digital image shift. | Adjust | <table border="1"> <thead> <tr> <th>Submenu</th> <th>Function</th> </tr> </thead> <tbody> <tr> <td>Adjust</td> <td>Adjust the image vertically and horizontally.</td> </tr> <tr> <td>Chart</td> <td>Display a chart (point selection window).</td> </tr> </tbody> </table> | Submenu | Function | Adjust | Adjust the image vertically and horizontally. | Chart | Display a chart (point selection window). |
| | Submenu | Function | | | | | | | | | | | |
| | Off | Disable micro-digital image shift. | | | | | | | | | | | |
| Adjust | <table border="1"> <thead> <tr> <th>Submenu</th> <th>Function</th> </tr> </thead> <tbody> <tr> <td>Adjust</td> <td>Adjust the image vertically and horizontally.</td> </tr> <tr> <td>Chart</td> <td>Display a chart (point selection window).</td> </tr> </tbody> </table> | Submenu | Function | Adjust | Adjust the image vertically and horizontally. | Chart | Display a chart (point selection window). | | | | | | |
| | Submenu | Function | | | | | | | | | | | |
| | Adjust | Adjust the image vertically and horizontally. | | | | | | | | | | | |
| Chart | Display a chart (point selection window). | | | | | | | | | | | | |
| | | | | | | | | | | | | | |
| | | | | | | | | | | | | | |
| Registration | Color misalignment affecting the entire image can be corrected by moving red, green, or blue components into position, in 1-pixel increments. | | | | | | | | | | | | |
| Advanced registration | <p>Precise correction of red, green, or blue misalignment in different areas of the screen is possible by color and area. For detailed instructions, refer to “Advanced Registration to Adjust Projected Images” (P187).</p> <p>[Off] Disable local correction of color misalignment. [Adjust] Display a menu for local correction of color misalignment.</p> | | | | | | | | | | | | |
| | <div style="border: 1px solid black; padding: 5px; margin-bottom: 10px;"> <p>Advanced registration</p> <p>5-point adjustment Off</p> <p>Manual adjustment</p> <p>Reset</p> <p style="background-color: yellow;">Return</p> </div> <table border="1"> <thead> <tr> <th>Submenu</th> <th>Function</th> </tr> </thead> <tbody> <tr> <td rowspan="2">5-point adjustment</td> <td>Off Disable adjustment.</td> </tr> <tr> <td>Adjust Enter 5-point adjustment mode (in screen corners and at the center).</td> </tr> <tr> <td>Manual adjustment</td> <td>Precise adjustment based on 54 points (in a 6 x 9 grid).</td> </tr> <tr> <td>Reset</td> <td>Restore the original position, before adjustment.</td> </tr> </tbody> </table> <div style="border: 1px solid gray; padding: 5px; margin-top: 10px;"> <p> With advanced registration, checkered or halftone image areas may be affected by uneven colors or image artifacts.</p> </div> | Submenu | Function | 5-point adjustment | Off Disable adjustment. | Adjust Enter 5-point adjustment mode (in screen corners and at the center). | Manual adjustment | Precise adjustment based on 54 points (in a 6 x 9 grid). | Reset | Restore the original position, before adjustment. | | | |
| Submenu | Function | | | | | | | | | | | | |
| 5-point adjustment | Off Disable adjustment. | | | | | | | | | | | | |
| | Adjust Enter 5-point adjustment mode (in screen corners and at the center). | | | | | | | | | | | | |
| Manual adjustment | Precise adjustment based on 54 points (in a 6 x 9 grid). | | | | | | | | | | | | |
| Reset | Restore the original position, before adjustment. | | | | | | | | | | | | |



- [Registration] and [Advanced registration] settings are retained even if you change the panel drive mode.
- 5-point adjustment enables basic correction of color misalignment across the screen, by moving adjustment points in the center and each corner. To correct registration only in certain areas, try manual adjustment.
- Any values you set in 5-point adjustment are retained if you subsequently perform manual adjustment. For more precise correction after 5-point adjustment, perform manual adjustment.
- Any manual adjustment values you set before switching to 5-point adjustment are cleared.

High altitude

Switch the fan mode to suit installation at low or high altitudes (above 2,300 m [7,545.8']).

| Option | Function |
|--------|--|
| Off | Setting for altitudes lower than 2,300 m (7,545.8'). |
| On | Setting for altitudes of 2,300 m (7,545.8') or higher. |



Incorrect settings may shorten the useful life of the other parts.

Operating mode

Switch the method of controlling the light source and fan.

| Option | Function |
|------------------|---|
| Normal | Normal drive mode. Brightness will decrease with time. |
| Fixed brightness | Maintains nearly the same brightness set at installation. Laser diode wear is detected by a sensor, and current is increased to compensate for wear. |
| Long duration 1 | Enables a relatively longer useful life of optical parts by reducing the brightness level of the light source mode and regulating the fan drive. |
| Long duration 2 | Enables an even longer useful life of optical parts by further reducing the brightness level of the light source mode and more aggressively regulating the fan drive. |



When using the projector continuously for 24 hours or more, or when turning the projector off by unplugging it, execute light source calibration using one of the settings below. If calibration is not executed, the projector will be unable to maintain fixed brightness.

- Periodically specify [OK] in [Light source calibration] in [Calibration] (P132).
- Specify CALIBRATION in [Schedule] (P129).

Marginal focus

In dome projection, image focus can be adjusted on the edges of the screen, and the remote control can be used to activate and deactivate this focus adjustment. For detailed instructions, refer to “Adjusting Peripheral Focus” (P191).

| Option | Function |
|--------|---|
| Off | Disable remote focusing of image edges. |
| On | Enable remote focusing of image edges. To access the adjustment window, press the LENS button on the projector twice or press the FOCUS button on the remote twice. |
| Reset | Restore edge focusing to the standard position. |



Setting this function to [Off] only prevents display of the adjustment window. Adjustment values are still retained. Use this setting to prevent remote focusing of image edges.

Edge blending

Brightness and colors of overlapping edges of images from multiple projectors, which form a blending area, can be adjusted for a more seamless appearance. For detailed instructions, see “Projecting from Multiple Projectors at Once (Edge Blending)” (P183).

[Off] Disable blending.

[Adjust] Display the menu for blending area adjustment.

| Edge blending | | |
|---------------------------|-------|----------------|
| Side | Width | Start position |
| Left | 0 | 0 |
| Right | 0 | 0 |
| Top | 0 | 0 |
| Bottom | 0 | 0 |
| Color blending adjustment | Off | |
| Black level adjustment | Off | |
| Marker | Off | |
| Reset | | |
| Return | | |

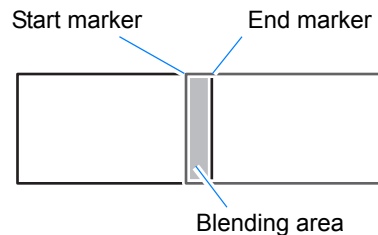

When adjusting the image projected from the right side



- Adjustment may not eliminate different colors or brightnesses in the blending area.
- For best edge-blending results, use all projectors in the same image mode (Optimal image mode: [Photo/sRGB].) and make the following adjustments.
 - Brightness, contrast, R/G/B gain, R/G/B offset, black level, color blending, color temperature, color level, color balance, sharpness, gamma, HDR range, light source mode, brightness level
 - Color adjustment, by using 6-axis color adjustment
 - Gamma adjustment, by fine-tuning gamma
 - Corner adjustment, using keystone correction

| Submenu | Function | |
|---------------------------|--|--|
| Side | Submenu | Function |
| | Left | Select the direction of the blending area to adjust. |
| | Right | |
| | Top | |
| | Bottom | |
| | Width | Specify the width between the start and end markers. |
| Start position | <p>Moves the position of the start marker.</p>  <ul style="list-style-type: none"> • Large blending areas may cover input signal dialog boxes and other interface elements. In this case, momentarily set edge blending to [Off] and check the display. • Although the starting marker is normally aligned with the image edge, it can also be aligned toward the center of the image. In this case, the black blending area will lie outside of the starting marker. | |
| Color blending adjustment | Adjust unwanted colors or discrepancies between colors in the blending area. | |
| | Submenu | Function |
| | Off | Do not adjust colors of blended images. |
| | Adjust | Adjust unwanted colors or discrepancies between colors in the blending area. |
| Option | | Function |
| White | | Simultaneously adjust red, green, and blue to correct unwanted colors or discrepancies in the blending area. |
| Red/Green/Blue | Individually adjust red, green, and blue to correct unwanted colors or discrepancies in the blending area. | |

Menu Settings

| Submenu | Function | | | | | | |
|--|--|---------------------------------|----------------------|---|--|---|---|
| Black level adjustment | <p>Because black is lighter in the blending area than in other areas, you can adjust the black level outside the blending area to make this difference in brightness less noticeable.</p> <p>Area A: Black level cannot be adjusted. Area B: Adjust to a black level different from that of area D. Area C: Adjust to provide a smooth transition relative to the black levels of areas B and D.</p> | | | | | | |
| | <p>Off Do not adjust the black level.</p> | | | | | | |
| | <p>Area Adjust areas C - A to smoothen the boundaries of the blending area.</p> <table border="1"> <thead> <tr> <th>Submenu</th> <th>Function</th> </tr> </thead> <tbody> <tr> <td>Side</td> <td>Select the direction to adjust from Left/Right/Top/Bottom.</td> </tr> <tr> <td>A-Width/ B-Width/ C-Width</td> <td>Adjust the widths of areas A - C.</td> </tr> </tbody> </table> | Submenu | Function | Side | Select the direction to adjust from Left/Right/Top/Bottom. | A-Width/ B-Width/ C-Width | Adjust the widths of areas A - C. |
| | Submenu | Function | | | | | |
| Side | Select the direction to adjust from Left/Right/Top/Bottom. | | | | | | |
| A-Width/ B-Width/ C-Width | Adjust the widths of areas A - C. | | | | | | |
| <p>Black level Adjust the black level brightness and color of areas B and D.</p> <table border="1"> <thead> <tr> <th>Submenu</th> <th>Function</th> </tr> </thead> <tbody> <tr> <td>B/D-area base</td> <td>Adjust the black level brightness of B/D areas.</td> </tr> <tr> <td>B/D-area red / green / blue</td> <td>Adjust the red, green, and blue components of B/D area black levels individually.</td> </tr> </tbody> </table> <p> Adjustment values are restored even if the dialog box is no longer displayed after you select [Adjust] again after setting [Black level adjustment] to [Off].</p> | Submenu | Function | B/D-area base | Adjust the black level brightness of B/D areas. | B/D-area red / green / blue | Adjust the red, green, and blue components of B/D area black levels individually. | |
| Submenu | Function | | | | | | |
| B/D-area base | Adjust the black level brightness of B/D areas. | | | | | | |
| B/D-area red / green / blue | Adjust the red, green, and blue components of B/D area black levels individually. | | | | | | |
| Marker | <p>Show the blending area markers.</p> <table border="1"> <thead> <tr> <th>Option</th> <th>Function</th> </tr> </thead> <tbody> <tr> <td>Off</td> <td>Hide the blending area markers.</td> </tr> <tr> <td>On</td> <td>Show the blending area markers. The start marker is red, and the end marker is green.</td> </tr> </tbody> </table> | Option | Function | Off | Hide the blending area markers. | On | Show the blending area markers. The start marker is red, and the end marker is green. |
| | Option | Function | | | | | |
| | Off | Hide the blending area markers. | | | | | |
| On | Show the blending area markers. The start marker is red, and the end marker is green. | | | | | | |
| Reset | Reset the marker settings. | | | | | | |

Lens - Position

 > [Install settings] > **[Lens - Position]**

The projector can store information about the lens position. Up to three sets of lens information (including, focus, zoom, and lens shift settings) can be saved, and the lens can be restored to these positions as needed.

| Submenu | Function |
|-------------------|---|
| Load position 1-3 | Restores the lens to the positions saved using [Save position 1] - [Save position 3]. |
| Save position 1-3 | Saves the lens position as one of the available positions (1-3). |
| Lens shift reset | Restores the lens to the original position. |



- When saved lens positions are restored, images may be slightly misaligned, relative to the saved position.
- Specifying a somewhat smaller image size than the screen size (image area) enables you to switch among multiple lens positions without the image extending off the screen.
- When precise positioning is needed, use lens shift, zoom, and focus functions to fine-tune the position.
- [Save position] and [Lens shift reset] are not available when [Positional lock] is set to [On] (P107).
- [Load position] is grayed out and not available unless positions have been stored to a [Save position].
- The following setting values are stored: focus, zoom, lens shift, keystone, corner adjustment, and screen color.

Screen color

 > [Install settings] > **[Screen color]**

You can adjust the color quality of the images projected according to the color of the projection screen.

| Submenu | Function |
|------------|---|
| Normal | Select this if a standard type of projection screen is used. The images are projected in a light quality similar to that of natural light. |
| Greenboard | Select if a dark green surface such as a blackboard is used as the screen. The color quality similar to [Normal] is obtained on the greenboard. |
| Adjust | Select to fine-tune the gain and offset of red, blue, and green. |

Iris



> [Install settings] > **[Iris]**

Use this feature for projection emphasizing contrast over brightness.

| Submenu | Function |
|-----------|---|
| Open | Disables aperture adjustment. |
| Close 1-3 | Specify the aperture value in a range of 1-3. |



The [Iris] setting does not affect power consumption.

Test pattern



> [Install settings] > **[Test pattern]**

You can project a test pattern ([P197](#)) to check resolution, color, and other details even without supplying an input signal. Also available by pressing the **TEST PATTERN** button on the remote control.

| Option | Function |
|--------|-------------------------------|
| Off | Disable test pattern display. |
| On | Enable test pattern display. |



- While the test pattern is displayed, you can use the [▲] / [▼] buttons to switch patterns. Additionally, options of test pattern that have options can be changed with the [◀] / [▶] buttons.
- The test pattern menu is no longer displayed after a little while, but you can view it again by pressing the [▲] / [▼] buttons.

System settings

Customize projector and remote control operation, beeping, and other details after startup, during standby, and in other situations.

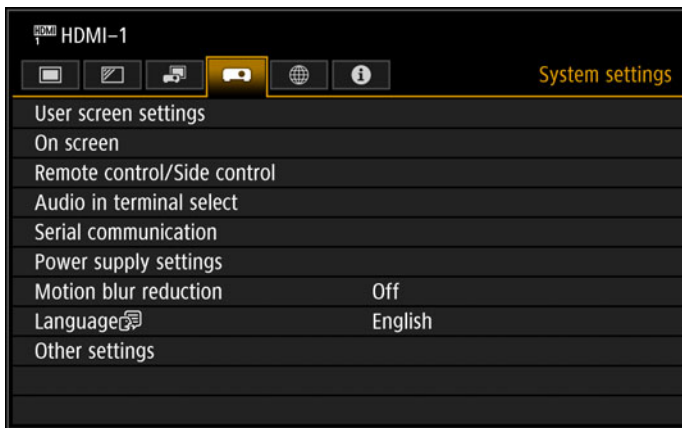

(When the input signal is HDMI-1)

| Menu | Function | Details |
|-----------------------------|--|----------------------|
| User screen settings | Customize user screens shown at startup, when no signal is detected, and in other situations. | P118 |
| On screen | Set the display position and whether to show or hide menus, help information, and warning or caution icons. | P119 |
| Remote control/Side control | Specify operation with remote control or projector buttons. | P121 |
| Audio in terminal select | Select the terminal for audio input. | P123 |
| Serial communication | Display serial communication setting values. | P123 |
| Power supply settings | Specify how power is managed at startup, in standby, and when no signal is supplied. | P123 |
| Motion blur reduction | Motion blur is blurring that occurs during video playback. Motion blur reduction can make this blurring less noticeable. | P125 |
| Language | You can select the language in which the menus are displayed. | P126 |
| Other settings | Set a password, check the air filter replacement timing, schedule operation, and access other settings and information. | P127 |

Menus that are not available are grayed out.

User screen settings

 > [System settings] > [User screen settings]

Capture a logo and specify logo display settings.

| | |
|----------------------|------------|
| User screen settings | |
| Logo capture | |
| Logo position | Center |
| No signal screen | Blue |
| Screen when blank | Black |
| Projector on | Canon logo |
| Return | |

Logo capture

Registers the current image as a user logo. Registered user logos can be shown when no signal is received, when the **BLANK** button is pressed, or as the startup image.

| Option | Function |
|--------|--|
| OK | Display the image for logo registration. Align the image with the red boundary lines indicating the portion that will be stored, and then press the OK button. The portion of the image within the boundary lines is now registered. |
| Cancel | Cancels logo registration. |

Logo position

Specify the position of registered user logos as follows.

You can specify the position after a logo has been registered. Choose from upper left, upper right, center, lower left, or lower right.

No signal screen

Customize the screen shown when no input signals are received.

| Option | Function |
|-----------|-----------------------------|
| Black | The screen is all black. |
| Blue | The screen is all blue. |
| User logo | The user logo is projected. |

Screen when blank

Select the screen shown when projection is temporarily blanked out by pressing the **BLANK** button on the remote control.

| Option | Function |
|------------------|---------------------------------|
| Black | The screen is all black. |
| Blue | The screen is all blue. |
| Light source off | The light source is turned off. |
| User logo | The user logo is projected. |

Projector on

Select a logo to project after startup until input signals can be projected.

| Option | Function |
|------------|--|
| Skip | A black screen is projected. |
| Canon logo | Displays the Canon logo that was registered in advance at the factory. |
| User logo | The user logo is projected. |

On screen

 > [System settings] > **[On screen]**

Specify display details for on-screen menus, help, and warning or precaution icons.

| | |
|----------------------------|---------|
| On screen | |
| Menu position | Upper L |
| Menu display time | Normal |
| Menu rotation | None |
| Guide | On |
| Show input status | On |
| Air filter warning display | On |
| Overheat warning display | Off |
| Return | |

Menu position

Reposition menu display.

Choose from upper left, upper right, center, lower left, or lower right.



Only [Center] is available when edge blending is used. Other display positions are grayed out and not available.

Menu display time

Extend menu display from the standard 10 or 30 seconds to 3 minutes.

| Option | Function |
|----------|---|
| Normal | The menu is displayed for 10 or 30 seconds. |
| Extended | The menu is displayed for 3 minutes. |

The display times of the following menus are also changed.

| Item | [Normal] | [Extended] |
|--|------------|------------|
| Menu screen | 30 seconds | 3 minutes |
| - Input (P55) - Keystone adjustment (P65) - Keystone reset (P67) - Focus (P59), Zoom (P60), Lens shift (P62), Lens shift reset (P63) - Marginal focus (P112) - Aspect (P64) - Image mode (P68) - Gamma (P99) - Volume adjustment (P29, P34) | 10 seconds | 3 minutes |



The windows for manual adjustment or 5-point adjustment in RGB alignment, and for other settings such as date and time settings, are shown for 3 minutes, regardless of the [Normal] or [Extended] option.

Menu rotation

Rotate menu display. When projecting in portrait orientation, for example, with the projector installed at a 90° angle, specify the orientation of projected menus to align them with the top or bottom of projected images.

| Option | Function |
|-----------------------------|--|
| Auto | Automatically rotates menus as needed after using an accelerometer to determine if the projector is installed in portrait orientation (90° clockwise or counterclockwise) or horizontally. |
| Off | Menus are not rotated. Menus are shown in a readable orientation for projectors installed horizontally. |
| 90 degrees counterclockwise | Menus are rotated 90°. Menus are shown in a readable orientation for projectors installed in portrait orientation (90° clockwise or counterclockwise). |
| 90 degrees clockwise | |



- To determine the orientation of menu rotation, projector orientation is detected immediately after startup or when this setting is switched to [Auto].
- Menus are not rotated automatically in response to changes in projector orientation during projection.

Guide

As you use the projector, messages are shown as guidance to introduce features and operation.

| Option | Function |
|--------|-------------------------|
| Off | Hides the guide screen. |
| On | Shows the guide screen. |



The guide screen is shown at the following cases.

- No input signal is detected.
- An invalid button is pressed in [BLANK] or [FREEZE] mode. (P34)
- When positional lock (P107) is set to [On] and buttons locked by this feature are pressed.

Show input status

Shows input signal status when there is no signal, or when you are completing signal settings.

| Option | Function |
|--------|------------------------------------|
| Off | The input status is not displayed. |
| On | The input status is displayed. |

Air filter warning display

Shows a warning to replace the air filter when replacement is required.

| Option | Function |
|--------|--|
| Off | The air filter warning is not displayed. |
| On | The air filter warning is displayed. |



Setting [Air filter warning display] to [Off] will disable display of the warning to replace the air filter. We recommend checking the air filter counter (P133) occasionally to know when to replace the filter.

Overheat warning display

Shows a warning icon when the internal temperature is high and the projector may overheat.

| Option | Function |
|--------|--|
| Off | Disable high temperature warning icon display. |
| On | Enable high temperature warning icon display. |

Remote control/Side control

 > [System settings] > **[Remote control/Side control]**

Specify which operations are available using buttons on the remote control or in the projector's side controls.

| | |
|-----------------------------|-------------|
| Remote control/Side control | |
| Beep | On |
| Key repeat | On |
| Key lock | Off |
| Remote control channel | Independent |
| Return | |

Beep

You can select whether a beep sounds or not when you operate the projector.

| Option | Function |
|--------|--------------------|
| Off | Disables the beep. |
| On | Enables the beep. |



The beep will not sound if you mute the projector sound with the **MUTE** button on the remote control.

Key repeat

Key repeat enables projector or remote control buttons to be held down instead of pressing them repeatedly.

| Option | Function |
|--------|----------------------------|
| Off | Key repeat is not enabled. |
| On | Key repeat is enabled. |

Key lock

Lock the projector or remote (wireless) to prevent operation.

| Option | Function |
|-------------------|--|
| Off | Disables key lock. Operation is possible on the main unit or from the remote control. |
| Main unit | Operation is not possible using the main unit. Use the remote control. |
| Remote (wireless) | Disables infrared remote control operations (P36). Use buttons on the main unit. Operation is also possible with a wired remote control. |

To Unlock Key Lock Function

Turn off the projector and unplug the power plug. Hold down the **OK** button on the main unit and plug in the power cord, as you continue to hold down the **OK** button. In a moment, a beep will sound, and the controls will be unlocked.



When you access this setting from the projector's side controls, [Main unit] is not available. Similarly, when you access the setting from the remote control, [Remote (wireless)] is not available.

Remote control channel

Separate channels can be assigned to up to four projectors so that a single remote control can be used with each projector.

Selecting the Projector Channel

If a wired remote control is used, there is no need to set the remote control channel.

| Option | Function |
|-------------|---|
| Ch1 | Select the remote control channel to use with this projector. |
| Ch2 | |
| Ch3 | |
| Ch4 | |
| Independent | Can be controlled from a remote control set to any channel. |

Selecting a Channel on the Remote Control

After changing the projector channel from the menu, always change the remote control channel accordingly.

| | |
|-------------|---|
| Ch1 | Hold down both the Ch button and [1] button for 3 seconds. |
| Ch2 | Hold down both the Ch button and [2] button for 3 seconds. |
| Ch3 | Hold down both the Ch button and [3] button for 3 seconds. |
| Ch4 | Hold down both the Ch button and [4] button for 3 seconds. |
| Independent | Hold down both the Ch button and [0] button for 3 seconds. |

Audio in terminal select

 > [System settings] > **[Audio in terminal select]**

Select the terminal for audio input used with various input signals.

| Submenu | Function | |
|---------------|--------------------------------------|--|
| DVI-1 | Select the terminal for audio input. | |
| DVI-2 | Option | Function |
| DVI-3 | Off | No audio is output. |
| DVI-4 | Audio in | Use audio signals from AUDIO IN for audio output. |
| HDMI-1 | HDMI-1 | Only available when the submenu is [HDMI-1] or [HDMI 1x2]. Audio signals from HDMI-1 are output. |
| HDMI-2 | | |
| DVI 1x2 | HDMI-2 | Only available when the submenu is [HDMI-2] or [HDMI 1x2]. Audio signals from HDMI-2 are output. |
| DVI 2x2 / 1x4 | | |
| HDMI 1x2 | | |

Serial communication

 > [System settings] > **[Serial communication]**

You can check setting values for the service port (CONTROL) used for serial communication.

| Option | Function | |
|-----------|--------------------------------------|--------------------------------|
| Baud rate | Modulation rate, in bits per second. | |
| Data bits | Number of bits of data. | |
| Parity | Number of parity bits. | |
| Stop bit | Stop bit length. | |
| | Option | Function |
| | 1 | Sets the stop bit length to 1. |
| | 2 | Sets the stop bit length to 2. |

Power supply settings

 > [System settings] > **[Power supply settings]**

Specify how power is managed at startup, in standby, and when no signal is supplied.

| Power supply settings | |
|---------------------------|------------------|
| Standby power setting | |
| Quick startup | Off |
| Power management mode | Light source off |
| Power management duration | 5 min. |
| Direct power on | On |
| Return | |

Standby power setting

Specify network function operating status in standby mode.

| Option | Function |
|-----------|--|
| Normal | All network functions are available when network functions are enabled, including the web screen and PJLink. |
| Low-power | All network functions are available even in standby mode. However, the projector may be less responsive than usual when some functions are initially used. |



- If [Low-power] is selected, some features may take a long time to access on the network. For quicker access, select [Normal].
- [Standby power setting] is not available when [Quick startup] is set to [On].
- [Standby power setting] is set to [Normal] and cannot be changed when scheduling is enabled (P129).
- [Standby power setting] is set to [Normal] and cannot be changed when wireless LAN is enabled (P136).

Quick startup

Enable faster startup next time by leaving some circuits on for 90 minutes after the projector is turned off. However, to avoid sudden surges in intensity, projection is delayed by at least approximately 1.7 seconds.

| Option | Function |
|--------|------------------------|
| Off | Disable quick startup. |
| On | Enable quick startup. |

Power management mode

Specify to turn the light source off or enter standby if there is no input signal. This feature automatically turns off the light source or power after a certain period if the remote control or projector is not operated.

| Option | Function |
|------------------|---|
| Disabled | Disable power management mode. |
| Light source off | Only turns the light source off. |
| Standby | Turns the projector off and puts it in standby. |



- Projection resumes when the same input signal is restored, when the remote control or projector is operated, or when user commands are sent to turn the projector on.
- After the projector enters standby, restoring projection requires the same steps as when turning the projector on normally.
- When [Disabled] is selected, [Direct power on] is not available.

Power management duration

Specify how much time must pass before the light source goes off or the projector enters standby mode, depending on the [Power management mode] setting.

| Option | Function |
|------------------|--|
| 5 min. - 60 min. | After 30 seconds without an input signal when the projector is idle, the projector starts displaying a countdown of the selected time. |



- If conditions that would start countdown are met while you are blanking projection, blanking is canceled.
- Once countdown begins, audio output stops.

Direct power on

You can turn on the projector by connecting the power cable without pressing the **POWER** button.

| Option | Function |
|--------|---|
| Off | The POWER button must be pressed to turn the projector on. |
| On | You can turn on the projector by connecting the power cable only. |



Before enabling direct power on, be sure to set [Power management mode] to an option other than [Disabled]. When [Disabled] is selected, [Direct power on] is not available.

Motion blur reduction



> [System settings] > **[Motion blur reduction]**

Motion blur is blurring that occurs during video playback. Motion blur reduction can make this blurring less noticeable.

| Option | Function |
|--------|---|
| Off | Motion blur reduction is not performed. |
| Weak | Reduce motion blur for fast-moving images. Note that images may be slightly darker, and flickering may occur. |
| Strong | Reduce motion blur for images moving faster than with [Weak]. Note that images may be darker, and flickering may occur. |



- If setting the projector to [Strong] or [Weak] produces distracting flickering, set it to [Off].
- [Motion blur reduction] is not available in [DICOM SIM] image mode. The menu is grayed out.

Language

 > [System settings] > **[Language]**

Select the menu display language.

| Language | | |
|--------------------------------|----------------------------|--------------------------------------|
| English English | Русский Russian | Čeština Czech |
| Deutsch German | Nederlands Dutch | Dansk Danish |
| Français French | Suomi Finnish | إنجليزي Arabic |
| Italiano Italian | Norsk Norwegian | 中文简体 Chinese (Simplified) |
| Español Spanish | Türkçe Turkish | 中文繁體 Chinese (Traditional) |
| Português Portuguese | Polski Polish | 한국어 Korean |
| Svenska Swedish | Magyar Hungarian | 日本語 Japanese |

Other settings

 > [System settings] > **[Other settings]**

Register a password, set a password, reset the air filter counter, schedule operation, and access other settings and information.

| | |
|------------------------|----------|
| Other settings | |
| Password settings | Off |
| Register password | |
| Date and time settings | |
| Schedule | |
| Calibration | |
| Trigger out | Off |
| Air filter counter | |
| Power counter | 3H |
| Firmware | 00.00131 |
| Factory defaults | |
| Return | |

Password settings

Disables the projector unless the correct password is entered.

| Option | Function |
|--------|--|
| Off | The projector can be used even if no password is entered. |
| On | The projector cannot be used unless you enter your password. |

To Cancel the Password

| | |
|------------------------------------|--|
| Cancellation on the Projector | Turn off the projector and unplug the power plug. Hold down the MENU button on the side control and connect the power plug. Make sure to keep holding down the MENU button until a beep sounds. When the projector beeps, the password is canceled. (The entered password is also reset.) |
| Cancellation on the Remote Control | To forcibly cancel the password from the remote control, in standby state press the MENU button 3 times, then press the POWER button. |



- You cannot set [On] unless you have completed [Register password]. Once you set a password, the password entry screen appears at power-on. Enter a 4 digit password. Enter the password using the [▲] / [▶] / [▼] / [◀] buttons or number buttons on the remote control. If the password is valid, the projection starts. If you enter a wrong password three times, the power will be turned off.
- The projector also goes off after 3 minutes of inactivity on the password input screen.

Register password

You can register a password for starting projection.

Enter a 4 digit password.



Enter the password using the pointer buttons [▲] (1) / [▶] (2) / [▼] (3) / [◀] (4) or the number buttons on the remote control.

The 4-digit password is entered from the left to right digits. When the final digit is entered, the password is automatically registered.

Press the **MENU** button to abort the registration.

Date and time settings

Set time settings such as the current date and time, date/time display format, daylight saving time, and time zone.

| Submenu | Function | | | | | | | | |
|---|---|-------------------------------|----------|------|-------------------------------|------|------------------------------|-------|--|
| Date and time | Set the date and time. The date and time currently set are shown and updated each second. | | | | | | | | |
| |  Fields are blank unless the real-time clock has been set. | | | | | | | | |
| | <table border="1"> <thead> <tr> <th>Submenu</th> <th>Function</th> </tr> </thead> <tbody> <tr> <td>Date</td> <td>Enter the date.</td> </tr> <tr> <td>Time</td> <td>Enter the time.</td> </tr> <tr> <td>Enter</td> <td>Confirms your entered values. Completing this setting activates the real-time clock.</td> </tr> </tbody> </table> | Submenu | Function | Date | Enter the date. | Time | Enter the time. | Enter | Confirms your entered values. Completing this setting activates the real-time clock. |
| | Submenu | Function | | | | | | | |
| Date | Enter the date. | | | | | | | | |
| Time | Enter the time. | | | | | | | | |
| Enter | Confirms your entered values. Completing this setting activates the real-time clock. | | | | | | | | |
|  <ul style="list-style-type: none"> The date/time display format is set in [Date display format]. Settings may be reset if the projector is left unplugged for an extended period. | | | | | | | | | |
| Date display format | Choose [Year/month/date], [Month/date/year], or [Date/month/year] as the date display format shown for the date and time, in schedules, and elsewhere. | | | | | | | | |
| Daylight saving time | Adjusts the time one hour ahead at the beginning of daylight saving time and one hour back at the end. The timing of daylight saving time must be set in advance. | | | | | | | | |
| | <table border="1"> <thead> <tr> <th>Option</th> <th>Function</th> </tr> </thead> <tbody> <tr> <td>Off</td> <td>Disable daylight saving time.</td> </tr> <tr> <td>On</td> <td>Enable daylight saving time.</td> </tr> <tr> <td>Edit</td> <td>Edit when daylight saving time starts and ends. Set the month, day, and time on the editing screen shown next for the starting and ending date/time.</td> </tr> </tbody> </table> | Option | Function | Off | Disable daylight saving time. | On | Enable daylight saving time. | Edit | Edit when daylight saving time starts and ends. Set the month, day, and time on the editing screen shown next for the starting and ending date/time. |
| | Option | Function | | | | | | | |
| | Off | Disable daylight saving time. | | | | | | | |
| On | Enable daylight saving time. | | | | | | | | |
| Edit | Edit when daylight saving time starts and ends. Set the month, day, and time on the editing screen shown next for the starting and ending date/time. | | | | | | | | |
|  [On] in [Daylight saving time] is not available until the starting and ending timing are set. | | | | | | | | | |
| Region | Select a city in the time zone where the projector is installed. The time zone of the city selected in [Time zone] is shown. | | | | | | | | |

| Submenu | Function | | | | | | | | |
|--|--|-----------------------------------|----------|-----------|-----------------------------------|-----------|-----------------------------------|-----|---------------|
| SNTP | Select whether to sync the time on the projector using SNTP (Simple Network Time Protocol). | | | | | | | | |
| | <table border="1"> <thead> <tr> <th>Submenu</th> <th>Function</th> </tr> </thead> <tbody> <tr> <td>On (IPv4)</td> <td>Use SNTP over an IPv4 connection.</td> </tr> <tr> <td>On (IPv6)</td> <td>Use SNTP over an IPv6 connection.</td> </tr> <tr> <td>Off</td> <td>Disable SNTP.</td> </tr> </tbody> </table> | Submenu | Function | On (IPv4) | Use SNTP over an IPv4 connection. | On (IPv6) | Use SNTP over an IPv6 connection. | Off | Disable SNTP. |
| | Submenu | Function | | | | | | | |
| | On (IPv4) | Use SNTP over an IPv4 connection. | | | | | | | |
| | On (IPv6) | Use SNTP over an IPv6 connection. | | | | | | | |
| Off | Disable SNTP. | | | | | | | | |
|  <ul style="list-style-type: none"> • [SNTP] is not available when [Network (wired/wireless)] is set to [Off/Off]. • Use the web screen to set the IP address of the SNTP server. [SNTP] is not available unless the SNTP server IP address has been set. | | | | | | | | | |

Schedule

Some projector tasks can be automated by scheduling them. As the timing of scheduled tasks, choose from [Default], which is not during a certain period, or one of five special period times that you set up.

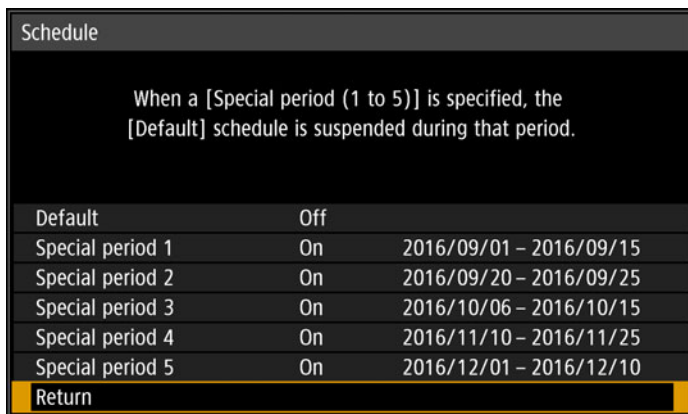

 The [Period] setting of a special period cannot be set to overlap with another period.

| Option | Function |
|--------------------|--|
| Default | Set a general schedule that is not during a specific period. |
| Special period 1-5 | Set up to five specific periods to schedule operation. |



- [On] is grayed out until you set the period in [Special period 1] to [Special period 5].
- Setting any schedule to [On] changes [Standby power setting] (P124) to [Normal].
- Tasks scheduled under the [Default] setting are not executed while special period schedules are in effect.

Detailed schedule setting

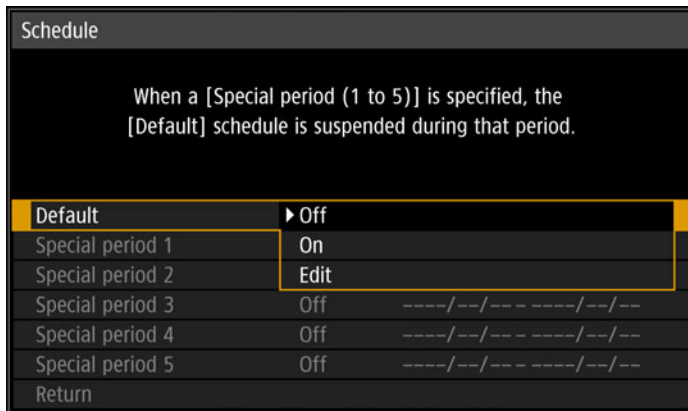

| Option | Function | | | | | | | | | | | | | | | | | | | | | | | | |
|---------|---|----------|-------|----|---------|-------|--------|---------|-------|-------|---------|-------|----------|---------|-------|---------|---------|-------|--------|---------|-------------|-------|---------|-------|-----|
| Off | Disable the schedule. | | | | | | | | | | | | | | | | | | | | | | | | |
| On | Enable the schedule. | | | | | | | | | | | | | | | | | | | | | | | | |
| Edit | <p>Edit the schedule.</p> <p>■ Default</p> <p>Detailed schedule setting [Default]</p> <p>Day of week ◀ Monday ▶</p> <p>Edit schedule</p> <table border="1"> <tr> <td>08 : 00</td> <td>POWER</td> <td>ON</td> </tr> <tr> <td>08 : 00</td> <td>INPUT</td> <td>HDMI-1</td> </tr> <tr> <td>10 : 00</td> <td>INPUT</td> <td>DVI-1</td> </tr> <tr> <td>12 : 00</td> <td>INPUT</td> <td>HDMI 1x2</td> </tr> <tr> <td>14 : 30</td> <td>INPUT</td> <td>DVI 1x2</td> </tr> <tr> <td>15 : 00</td> <td>INPUT</td> <td>HDMI-1</td> </tr> <tr> <td>17 : 00</td> <td>CALIBRATION</td> <td>LIGHT</td> </tr> <tr> <td>17 : 30</td> <td>POWER</td> <td>OFF</td> </tr> </table> <p>Reset</p> <p>Copy schedule to different day</p> <p>Return</p> | 08 : 00 | POWER | ON | 08 : 00 | INPUT | HDMI-1 | 10 : 00 | INPUT | DVI-1 | 12 : 00 | INPUT | HDMI 1x2 | 14 : 30 | INPUT | DVI 1x2 | 15 : 00 | INPUT | HDMI-1 | 17 : 00 | CALIBRATION | LIGHT | 17 : 30 | POWER | OFF |
| 08 : 00 | POWER | ON | | | | | | | | | | | | | | | | | | | | | | | |
| 08 : 00 | INPUT | HDMI-1 | | | | | | | | | | | | | | | | | | | | | | | |
| 10 : 00 | INPUT | DVI-1 | | | | | | | | | | | | | | | | | | | | | | | |
| 12 : 00 | INPUT | HDMI 1x2 | | | | | | | | | | | | | | | | | | | | | | | |
| 14 : 30 | INPUT | DVI 1x2 | | | | | | | | | | | | | | | | | | | | | | | |
| 15 : 00 | INPUT | HDMI-1 | | | | | | | | | | | | | | | | | | | | | | | |
| 17 : 00 | CALIBRATION | LIGHT | | | | | | | | | | | | | | | | | | | | | | | |
| 17 : 30 | POWER | OFF | | | | | | | | | | | | | | | | | | | | | | | |

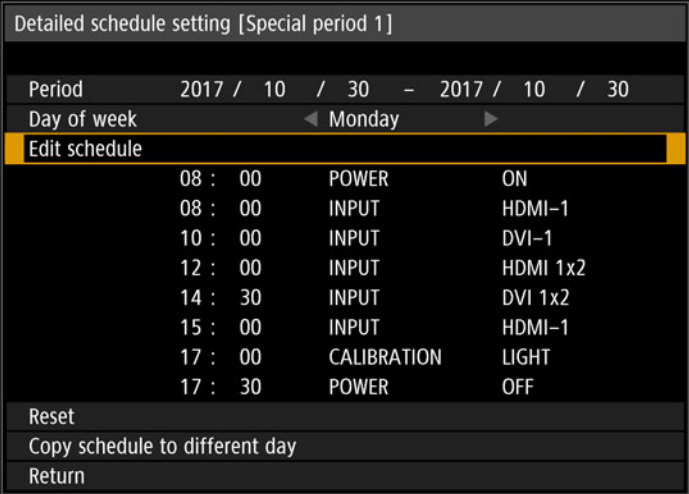
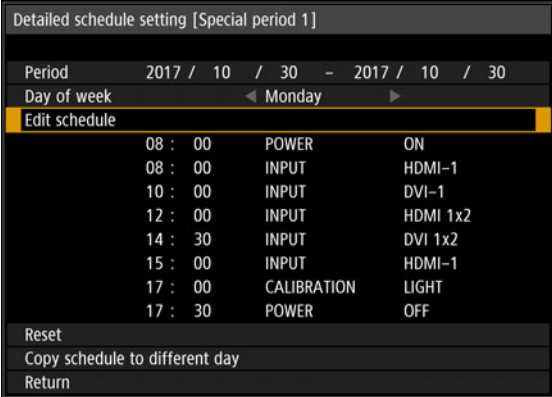
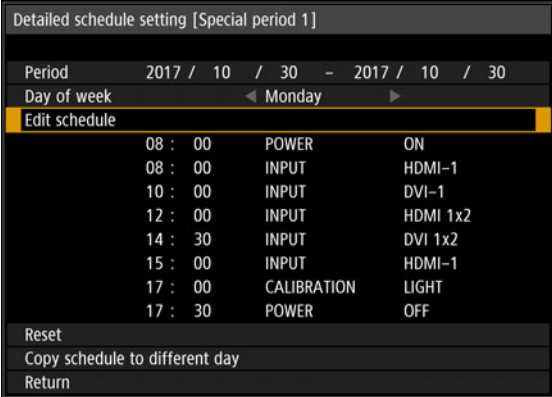

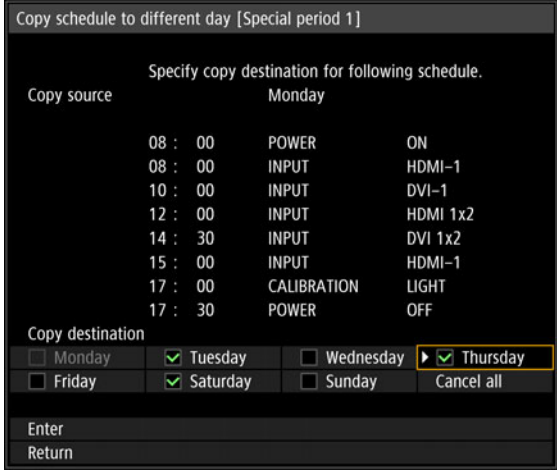
| Option | Function | | | | | | | |
|---------------|---|---------|----------|--------|--|-------------|-------------------------------------|---------------|
| <p>Edit</p> | <p>■ Special period</p>  <p>Select a day in [Day of week], and select the times, operations, and parameters. Light source calibration can also be scheduled during your specified period, by selecting CALIBRATION. (For details, see page 132.) However, the projector must project for at least 30 minutes before calibration, so it must be turned on in advance.</p> | | | | | | | |
| | <table border="1"> <thead> <tr> <th data-bbox="408 933 578 967">Submenu</th> <th data-bbox="578 933 1199 967">Function</th> </tr> </thead> <tbody> <tr> <td data-bbox="408 967 578 1070">Period</td> <td data-bbox="578 967 1199 1070">Edit the period (start and end dates) for scheduled operation. Note that no [Period] setting is used for the [Default] schedule.</td> </tr> <tr> <td data-bbox="408 1070 578 1105">Day of week</td> <td data-bbox="578 1070 1199 1105">Change the day of the week to edit.</td> </tr> <tr> <td data-bbox="408 1105 578 1657">Edit schedule</td> <td data-bbox="578 1105 1199 1657"> Edit the tasks scheduled for your selected [Day of week]. You can set or remove listed times, operations, and parameters (POWER ON/OFF, INPUT, CALIBRATION).  </td> </tr> </tbody> </table> | Submenu | Function | Period | Edit the period (start and end dates) for scheduled operation. Note that no [Period] setting is used for the [Default] schedule. | Day of week | Change the day of the week to edit. | Edit schedule |
| Submenu | Function | | | | | | | |
| Period | Edit the period (start and end dates) for scheduled operation. Note that no [Period] setting is used for the [Default] schedule. | | | | | | | |
| Day of week | Change the day of the week to edit. | | | | | | | |
| Edit schedule | Edit the tasks scheduled for your selected [Day of week]. You can set or remove listed times, operations, and parameters (POWER ON/OFF, INPUT, CALIBRATION).  | | | | | | | |

| Option | Function | |
|--------|--------------------------------|---|
| Edit | Submenu | Function |
| | Reset | Clears setting details for the selected schedule. Setting details for [Period] and day of the week are reset. |
| | Copy schedule to different day | <p>Copy the tasks scheduled for your selected [Day of week] to another day in the schedule copying menu.</p>  |

Calibration

Calibration adjusts the projector to compensate for changes in image quality from long-term use or differences in the environment of use.

| Submenu | Function | | | | | | |
|--|---|----------|----------|-----|--|--------|--|
| Gamma restore | Restore the original gamma if, after the projector has been used for some time, you notice that tone curves have changed, or if neutral colors have become tinted. Gamma restore can only be used after about 30 minutes of projection. | | | | | | |
| | <table border="1"> <thead> <tr> <th>Option</th> <th>Function</th> </tr> </thead> <tbody> <tr> <td>Off</td> <td>Returns to the factory default without performing Gamma restore.</td> </tr> <tr> <td>Adjust</td> <td>Restore the original gamma and apply the result.</td> </tr> </tbody> </table> | Option | Function | Off | Returns to the factory default without performing Gamma restore. | Adjust | Restore the original gamma and apply the result. |
| | Option | Function | | | | | |
| Off | Returns to the factory default without performing Gamma restore. | | | | | | |
| Adjust | Restore the original gamma and apply the result. | | | | | | |
| <ul style="list-style-type: none"> Restoring gamma will restore tone curves and neutral colors as closely as possible to defaults, but original projection cannot be matched exactly. If Gamma restore is performed, the adjustment screen will be projected for approximately 8 minutes. To stop Gamma restore, press the POWER or EXIT button. Cancellation will return the setting to [Off]. | | | | | | | |

| Submenu | Function | | | | | | |
|--|--|--------|----------|-----|---|-----------------|--|
| Adjust panel temperature | <p>Used when the gamma has changed in response to other changes, such as changes in ambient temperature. Compensates for changes in gradation caused by a change in LCOS panel temperature. This function can only be used after about 2 minutes of projection.</p> <table border="1"> <thead> <tr> <th>Option</th> <th>Function</th> </tr> </thead> <tbody> <tr> <td>Off</td> <td>Do not adjust the panels to suit the temperature.</td> </tr> <tr> <td>Adjust</td> <td>Adjust the panels to suit the temperature.</td> </tr> </tbody> </table> | Option | Function | Off | Do not adjust the panels to suit the temperature. | Adjust | Adjust the panels to suit the temperature. |
| Option | Function | | | | | | |
| Off | Do not adjust the panels to suit the temperature. | | | | | | |
| Adjust | Adjust the panels to suit the temperature. | | | | | | |
| Light source calibration | <p>Use when there is concern about deterioration of the color and luminance of the light source due to extended use.</p> <table border="1"> <thead> <tr> <th>Option</th> <th>Function</th> </tr> </thead> <tbody> <tr> <td>OK</td> <td>Execute light source calibration.</td> </tr> <tr> <td>Cancel</td> <td>Do not execute light source calibration.</td> </tr> </tbody> </table> | Option | Function | OK | Execute light source calibration. | Cancel | Do not execute light source calibration. |
| Option | Function | | | | | | |
| OK | Execute light source calibration. | | | | | | |
| Cancel | Do not execute light source calibration. | | | | | | |
| <p> Light source calibration can only be used after about 30 minutes of projection.</p> | | | | | | | |
| <h3>Trigger out</h3> <p>Operation of a screen or other external device can be triggered by turning the projector on or off.</p> <table border="1"> <thead> <tr> <th>Option</th> <th>Function</th> </tr> </thead> <tbody> <tr> <td>Off</td> <td>No output from the trigger terminal.</td> </tr> <tr> <td>Link with power</td> <td>12 V of voltage output from the trigger terminal during projection. Used to trigger operation of a screen or other external device in sync when the projector is turned on or off.</td> </tr> </tbody> </table> | | Option | Function | Off | No output from the trigger terminal. | Link with power | 12 V of voltage output from the trigger terminal during projection. Used to trigger operation of a screen or other external device in sync when the projector is turned on or off. |
| Option | Function | | | | | | |
| Off | No output from the trigger terminal. | | | | | | |
| Link with power | 12 V of voltage output from the trigger terminal during projection. Used to trigger operation of a screen or other external device in sync when the projector is turned on or off. | | | | | | |
| <h3>Air filter counter</h3> <p>This resets the counter which reminds you of the time for replacing the air filter. Also used to reset the counter after air filter replacement.</p> <p> For details on replacing the filter, see P194 - P196.</p> | | | | | | | |
| <h3>Power counter</h3> <p>Indicates the total time that the projector has been connected to a power supply.</p> <p> This value is not reset even if [Factory defaults] is executed.</p> | | | | | | | |

Firmware

Update the projector firmware.

Check the version indicated before updating the firmware.

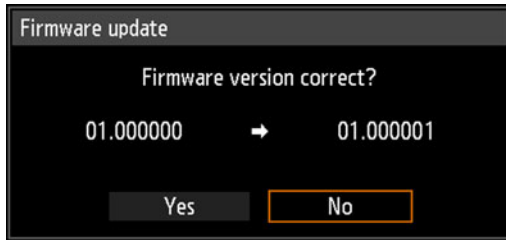

Update the projector firmware as follows.

1. Download updated firmware from the Canon website and store it at the root directory on a USB flash drive.
2. Insert the USB flash drive in the USB port.
3. Follow the instructions shown to complete the update process.



- Firmware versions shown here are for illustration only and differ from actual versions.
- In some cases, it may not be possible to download updates. For details, contact the Canon Customer Support Center.
- Firmware updating takes a few minutes. During the update, the LED indicator will flash in red. Do not turn off the projector while the LED is flashing. After the update, the projector will automatically turn itself off and enter standby mode.

Factory defaults

You can reset the menu item settings and restore the system settings to the factory defaults.

| Option | Function |
|--------|------------------------------------|
| OK | Settings are reset to default. |
| Cancel | Settings are not reset to default. |

Network settings

Network Connection Overview

Connecting the projector to a network enables you to control the projector from a computer and receive notification of projector errors via email.

Depending on the method of network connection, preparation on the computer side may be necessary. The following is an explanation of preparation on the computer side.

Connection Methods

The projector can be connected to a wired network with a LAN cable or to a wireless network via Wi-Fi.

Wired Networks

To connect the projector to a computer network, use a LAN cable.

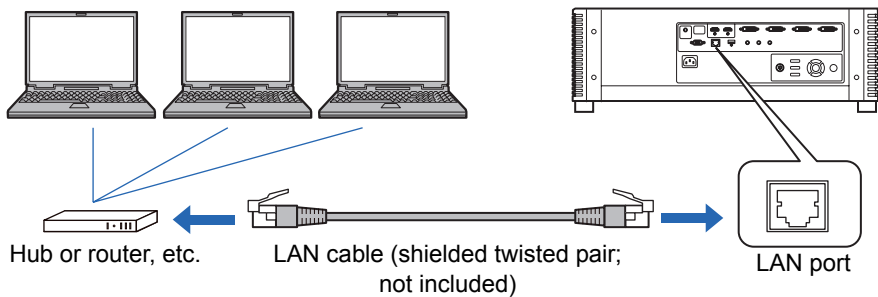

Wireless Networks

- **Projector Access Point (PJ AP) Mode**

The projector can be used as an access point for direct communication with wireless LAN-compatible computers.

Up to five computers can be connected at once.

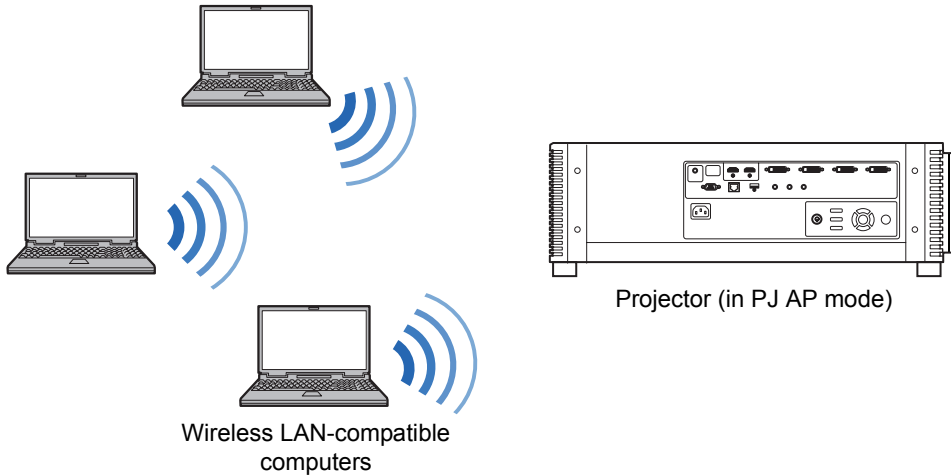

The following network features are available in PJ AP mode.

- Web features
- User commands

Other network features (specifically, SNMP, PJLink, Mail, AMX and Crestron RoomView) are not available.

- **Infrastructure Mode**

The projector can also be used as a wireless LAN client for connections to a wireless LAN access point.

In this case, the projector is connected to computers via the wireless LAN access point.

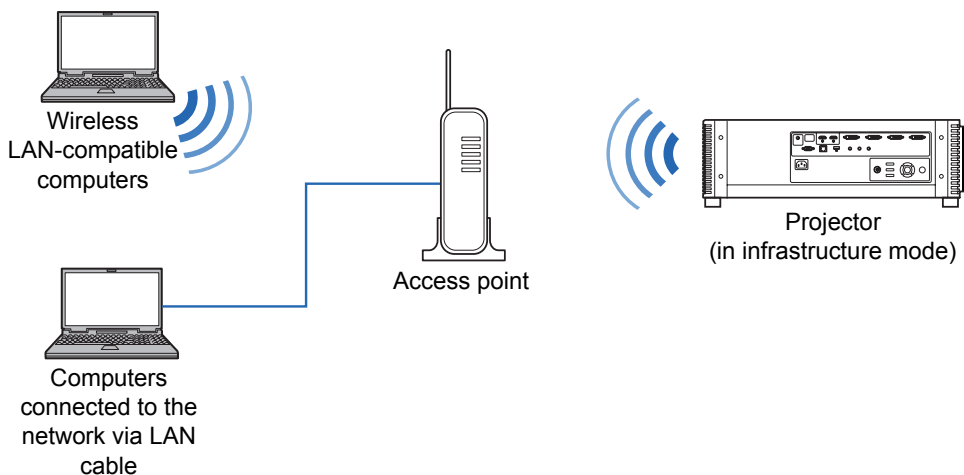



- The following network features are available in infrastructure mode.
 - Web features
 - Mail features
 - User commands

Other network features (specifically, SNMP, PJLink, AMX and Crestron RoomView) are not available.

- The following restrictions apply in infrastructure mode.
 - Access point SSIDs not in ASCII code (single-byte letters, numbers, or symbols) may cause character corruption in search result display.
 - Connectivity cannot be assured if access point SSIDs include characters not in ASCII code (single-byte letters, numbers, or symbols).

When multiple access points have the same SSID, only search results for the access point with the strongest signal are shown.

- Wired LAN features and infrastructure mode cannot be used at the same time.
- PJ AP and infrastructure modes cannot be used at the same time.
- Wired LAN and PJ AP mode cannot be used in the same subnet.
- Remember to set your preferred network (wired or wireless) to [On] if [Network (wired/wireless)] on the projector is set to [Off/Off] and the network connection is disabled. (P142) For wireless networks, choose the type of connection.
- Referring to “Checking Projector Information” (P155), confirm that the projector’s wired or wireless IP address is not the same as that of other computers on the network. To set a projector IP address, follow the instructions in “Completing Computer Settings for a Network Connection” (P156) and use the web screen, or use projector TCP/IP settings. (P144, P149)
- When you connect the computer to the network for the first time, it is also necessary to perform settings on the computer. In this case, consult the network administrator regarding the necessary settings.



Before connecting to a network environment that uses a DHCP server, set [DHCP] in the menu to [On] to enable the DHCP function. (P143, P149)

Wireless LAN (Wi-Fi)

■ Countries and Regions Where Wireless LAN Use Is Permitted

Use of the wireless LAN function is restricted under the laws, etc., of each country and region, and violation of these restrictions may be subject to punishment. Check the Canon website for a list of countries and regions where use of the wireless LAN function is permitted.

Canon assumes no responsibility whatsoever for problems, etc., that may arise from use of the wireless LAN function in countries and regions other than those listed.

■ Model Number

4K600STZ (including WLAN module model: CH9-1346)



FCC/IC NOTICE

Model: 4K600STZ (including WLAN Module Model CH9-1346, FCC ID: AZD221)

This device complies with Part 15 of FCC Rules and Industry Canada licence-exempt RSS standard(s). Operation is subject to the following two conditions: (1) this device may not cause interference, and (2) this device must accept any interference, including interference that may cause undesired operation of this device.

This transmitter must not be co-located or operated in conjunction with any other antenna or transmitter except Canon accessories supplied or designated for this product.

This equipment complies with FCC/IC radiation exposure limits set forth for an uncontrolled environment and meets the FCC radio frequency (RF) Exposure Guidelines and RSS-102 of the IC radio frequency (RF) Exposure rules. This equipment should be installed and operated keeping the radiator at least 20cm or more away from person's body.

Statement on EC directive

| |
|---|
| Canon Inc. tímto prohlašuje, že tento CH9-1346 je ve shodě se základními požadavky a dalšími příslušnými ustanoveními směrnice 1999/5/ES. |
| Undertegnede Canon Inc. erklærer herved, at følgende udstyr CH9-1346 overholder de væsentlige krav og øvrige relevante krav i direktiv 1999/5/EF. |
| Hiermit erklärt <i>Canon Inc.</i> , dass sich das Gerät CH9-1346 in Übereinstimmung mit den grundlegenden Anforderungen und den übrigen einschlägigen Bestimmungen der Richtlinie 1999/5/EG befindet. |
| Käesolevaga kinnitab <i>Canon Inc.</i> seadme CH9-1346 vastavust direktiivi 1999/5/EÜ põhinõuetele ja nimetatud direktiivist tulenevatele teistele asjakohastele sätetele. |
| Hereby, Canon Inc., declares that this CH9-1346 is in compliance with the essential requirements and other relevant provisions of Directive 1999/5/EC. |
| Por medio de la presente Canon Inc. declara que el CH9-1346 cumple con los requisitos esenciales y cualesquiera otras disposiciones aplicables o exigibles de la Directiva 1999/5/CE. |
| ΜΕ ΤΗΝ ΠΑΡΟΥΣΑ Canon Inc. ΔΗΛΩΝΕΙ ΟΤΙ CH9-1346 ΣΥΜΜΟΡΦΩΝΕΤΑΙ ΠΡΟΣ ΤΙΣ ΟΥΣΙΩΔΕΙΣ ΑΠΑΙΤΗΣΕΙΣ ΚΑΙ ΤΙΣ ΛΟΙΠΕΣ ΣΧΕΤΙΚΕΣ ΔΙΑΤΑΞΕΙΣ ΤΗΣ ΟΔΗΓΙΑΣ 1999/5/ΕΚ. |
| Par la présente Canon Inc. déclare que l'appareil CH9-1346 est conforme aux exigences essentielles et aux autres dispositions pertinentes de la directive 1999/5/CE. |
| Con la presente Canon Inc. dichiara che questo CH9-1346 è conforme ai requisiti essenziali ed alle altre disposizioni pertinenti stabilite dalla direttiva 1999/5/CE. |
| Ar šo Canon Inc. deklarē, ka CH9-1346 atbilst Direktīvas 1999/5/EK būtiskajām prasībām un citiem ar to saistītajiem noteikumiem. |
| Šiuo Canon Inc. deklaruoja, kad šis CH9-1346 atitinka esminius reikalavimus ir kitas 1999/5/EB Direktyvos nuostatas. |
| Hierbij verklaart Canon Inc. dat het toestel CH9-1346 in overeenstemming is met de essentiële eisen en de andere relevante bepalingen van richtlijn 1999/5/EG. |
| Hawnhekk, <i>Canon Inc.</i> , jiddikjara li dan CH9-1346 jikkonforma mal-ħtiġijiet essenzjali u ma provvedimenti oħrajn relevanti li hemm fid-Dirrettiva 1999/5/EC. |
| Alulírott, <i>Canon Inc.</i> nyilatkozom, hogy a CH9-1346 megfelel a vonatkozó alapvető követelményeknek és az 1999/5/EC irányelv egyéb előírásainak. |
| Niniejszym Canon Inc. oświadcza, że CH9-1346 jest zgodny z zasadniczymi wymogami oraz pozostałymi stosownymi postanowieniami Dyrektywy 1999/5/EC. |
| Canon Inc. declara que este CH9-1346 está conforme com os requisitos essenciais e outras disposições da Directiva 1999/5/CE. |
| Canon Inc. izjavlja, da je ta CH9-1346 v skladu z bistvenimi zahtevami in ostalimi relevantnimi določili direktive 1999/5/ES. |
| Canon Inc. tímto vyhlasuje, že CH9-1346 spĺňa základné požiadavky a všetky príslušné ustanovenia Smernice 1999/5/ES. |
| <i>Canon Inc.</i> vakuuttaa täten että CH9-1346 tyyppinen laite on direktiivin 1999/5/EY oleellisten vaatimusten ja sitä koskevien direktiivin muiden ehtojen mukainen. |
| Härmed intygar Canon Inc. att denna CH9-1346 står i överensstämmelse med de väsentliga egenskapskrav och övriga relevanta bestämmelser som framgår av direktiv 1999/5/EG. |
| Hér með lýsir Canon Inc. yfir því að CH9-1346 er í samræmi við grunnkröfur og aðrar kröfur, sem gerðar eru í tilskipun 1999/5/EC. |
| Canon Inc. erklærer herved at utstyret CH9-1346 er i samsvar med de grunnleggende krav og øvrige relevante krav i direktiv 1999/5/EF. |
| С настоящия документ Canon Inc. декларира, че CH9-1346 е в съгласие с основните изисквания и съответните постановления на Директива 1999/5/EC. |
| Prin prezenta, Canon Inc. declară că acest CH9-1346 este conform cu cerințele principale și cu celelalte prevederi relevante ale Directivei 1999/5/EC. |

Please contact the following address for the original Declaration of Conformity:

CANON EUROPA N.V.

Bovenkerkerweg 59, 1185 XB Amstelveen, The Netherlands

CANON INC.

30-2, Shimomaruko 3-chome, Ohta-ku, Tokyo 146-8501, Japan



Completing Projector Settings

Settings described in this section apply to wired and wireless network connections, setting a network password, and other aspects of networked projection.

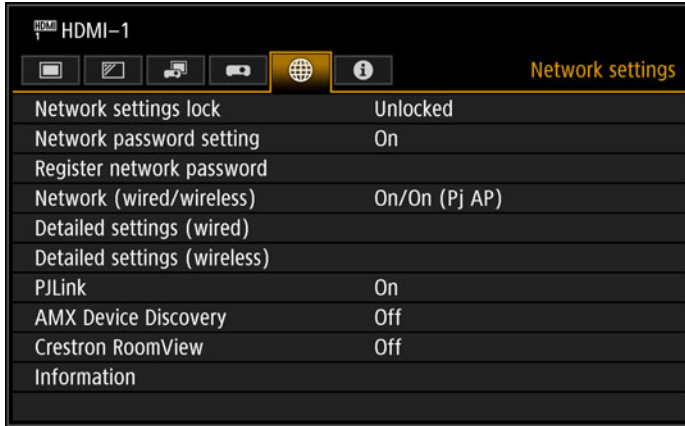

(When the input signal is HDMI-1)

| Menu | Function | Details |
|------------------------------|---|---------|
| Network settings lock | Lock network settings to prevent changes. | P141 |
| Network password setting | Specify whether network settings are password-protected. | P141 |
| Register network password | Set a network password. | P141 |
| Network (wired/wireless) | Enable or disable wired or wireless network connectivity and the mode of operation. | P142 |
| Detailed settings (wired) | Display and set advanced settings for wired connections. | P142 |
| Detailed settings (wireless) | Display and set advanced settings for wireless connections. | P147 |
| PJLink* | Enable or disable PJLink. | P152 |
| AMX Device Discovery* | Enable or disable AMX Device Discovery. | P153 |
| Crestron RoomView* | Enable or disable Crestron RoomView. | P153 |
| Information | Display network information. | P154 |

*Only available for wired connections.

Network settings lock

 > [Network Settings] > **[Network settings lock]**

You can lock/unlock the network settings so that they cannot be changed.

| Option | Function |
|--------|---|
| Unlock | Cancels the lock and allows other network settings to be changed. The password must be entered in order to cancel the lock. Use the [▲]/[▶]/[▼]/[◀] buttons or number buttons on the remote control to enter the four-digit network password. |
| Lock | Lock the settings. |



Forcibly canceling the network lock

Press these buttons in the following order to cancel the lock: [▲] [OK] [▶] [OK] [▼] [OK]. This operation resets the network password to [▲] [▲] [▲] [▲] ([1] [1] [1] [1]). Setting [Network password setting] to [Off] leaves network settings unlocked.

Network password setting

 > [Network settings] > **[Network password setting]**

You can set whether or not a password is required in order to change the projector network settings.

| Option | Function |
|--------|---------------------------------|
| Off | A network password is not used. |
| On | A network password is used. |

Register network password

 > [Network settings] > **[Register network password]**

Use the [▲] / [▶] / [▼] / [◀] buttons or number buttons on the remote control to enter the projector network password.



Network (wired/wireless)

 > [Network settings] > **[Network (wired/wireless)]**

Enable or disable wired or wireless network connectivity and the mode of operation. Specifying [Off] can save energy.

| Option | Function |
|----------------|---|
| Off/Off | Disables the network function. |
| On/Off | Enable only wired networking. |
| On/On (Pj AP) | Enable both wired and wireless (PJ AP mode) networking. |
| Off/On (Pj AP) | Enable only wireless (PJ AP mode) networking. |
| Off/On (Infra) | Enable only wireless (infrastructure mode) networking. |



Notes When Connected Wirelessly

- A message is displayed at the initial startup in PJ AP mode (P136) requesting that you check security key settings.

Detailed settings (wired)

 > [Network settings] > **[Detailed settings (wired)]**

Display and manually change the wired IP address, gateway address, and other settings. Available only when wired networking is [On].

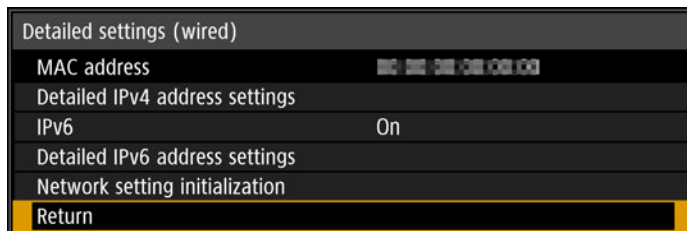

| Detailed settings (wired) | |
|--------------------------------|-------------------|
| MAC address | 00 00 00 00 00 00 |
| Detailed IPv4 address settings | |
| IPv6 | On |
| Detailed IPv6 address settings | |
| Network setting initialization | |
| Return | |

| Menu | Function |
|-------------|-------------------------------------|
| MAC address | Wired MAC address of the projector. |

| Menu | Function | | | | | | | | | | | | | | | | | | | | | | | | | | | | | | | | | | | |
|---|--|--|---|-------|---|----|--|-------|-------|-------|-----|-------------|-------|-------|-------|---|-----------------|-----|-----|-----|---|------|-----|--|--|--|-----------------|--|--|--|--|--------|--|--|--|--|
| Detailed IPv4 address settings | <p>Configure details of the projector's wired LAN (IPv4) function.</p> <table border="1" data-bbox="408 218 1094 446"> <thead> <tr> <th colspan="5">Detailed IPv4 address settings (wired)</th> </tr> </thead> <tbody> <tr> <td>IP address</td> <td>192 .</td> <td>168 .</td> <td>254 .</td> <td>254</td> </tr> <tr> <td>Subnet mask</td> <td>255 .</td> <td>255 .</td> <td>255 .</td> <td>0</td> </tr> <tr> <td>Gateway address</td> <td>0 .</td> <td>0 .</td> <td>0 .</td> <td>0</td> </tr> <tr> <td>DHCP</td> <td colspan="4">Off</td> </tr> <tr> <td colspan="5">TCP/IP settings</td> </tr> <tr> <td colspan="5">Return</td> </tr> </tbody> </table> | Detailed IPv4 address settings (wired) | | | | | IP address | 192 . | 168 . | 254 . | 254 | Subnet mask | 255 . | 255 . | 255 . | 0 | Gateway address | 0 . | 0 . | 0 . | 0 | DHCP | Off | | | | TCP/IP settings | | | | | Return | | | | |
| | Detailed IPv4 address settings (wired) | | | | | | | | | | | | | | | | | | | | | | | | | | | | | | | | | | | |
| | IP address | 192 . | 168 . | 254 . | 254 | | | | | | | | | | | | | | | | | | | | | | | | | | | | | | | |
| | Subnet mask | 255 . | 255 . | 255 . | 0 | | | | | | | | | | | | | | | | | | | | | | | | | | | | | | | |
| | Gateway address | 0 . | 0 . | 0 . | 0 | | | | | | | | | | | | | | | | | | | | | | | | | | | | | | | |
| DHCP | Off | | | | | | | | | | | | | | | | | | | | | | | | | | | | | | | | | | | |
| TCP/IP settings | | | | | | | | | | | | | | | | | | | | | | | | | | | | | | | | | | | | |
| Return | | | | | | | | | | | | | | | | | | | | | | | | | | | | | | | | | | | | |
| <table border="1"> <thead> <tr> <th>Submenu</th> <th>Function</th> </tr> </thead> </table> | Submenu | Function | | | | | | | | | | | | | | | | | | | | | | | | | | | | | | | | | | |
| Submenu | Function | | | | | | | | | | | | | | | | | | | | | | | | | | | | | | | | | | | |
| <table border="1"> <tbody> <tr> <td>IP address</td> <td>IP address of the wired LAN (IPv4).</td> </tr> </tbody> </table> | IP address | IP address of the wired LAN (IPv4). | | | | | | | | | | | | | | | | | | | | | | | | | | | | | | | | | | |
| IP address | IP address of the wired LAN (IPv4). | | | | | | | | | | | | | | | | | | | | | | | | | | | | | | | | | | | |
| <table border="1"> <tbody> <tr> <td>Subnet mask</td> <td>Subnet mask of the wired LAN (IPv4).</td> </tr> </tbody> </table> | Subnet mask | Subnet mask of the wired LAN (IPv4). | | | | | | | | | | | | | | | | | | | | | | | | | | | | | | | | | | |
| Subnet mask | Subnet mask of the wired LAN (IPv4). | | | | | | | | | | | | | | | | | | | | | | | | | | | | | | | | | | | |
| <table border="1"> <tbody> <tr> <td>Gateway address</td> <td>Gateway address of the wired LAN (IPv4).</td> </tr> </tbody> </table> | Gateway address | Gateway address of the wired LAN (IPv4). | | | | | | | | | | | | | | | | | | | | | | | | | | | | | | | | | | |
| Gateway address | Gateway address of the wired LAN (IPv4). | | | | | | | | | | | | | | | | | | | | | | | | | | | | | | | | | | | |
| <table border="1"> <tbody> <tr> <td rowspan="3">DHCP</td> <td>Option</td> <td>Function</td> </tr> <tr> <td>Off</td> <td>Disables the DHCP function. TCP/IP settings can be configured manually.</td> </tr> <tr> <td>On</td> <td>Enables the DHCP function. Searches the DHCP server. It will no longer be possible to enter the IP address, subnet mask, or gateway address manually, because the IP address is acquired from the DHCP server.</td> </tr> </tbody> </table> | DHCP | Option | Function | Off | Disables the DHCP function. TCP/IP settings can be configured manually. | On | Enables the DHCP function. Searches the DHCP server. It will no longer be possible to enter the IP address, subnet mask, or gateway address manually, because the IP address is acquired from the DHCP server. | | | | | | | | | | | | | | | | | | | | | | | | | | | | | |
| DHCP | | Option | Function | | | | | | | | | | | | | | | | | | | | | | | | | | | | | | | | | |
| | | Off | Disables the DHCP function. TCP/IP settings can be configured manually. | | | | | | | | | | | | | | | | | | | | | | | | | | | | | | | | | |
| | On | Enables the DHCP function. Searches the DHCP server. It will no longer be possible to enter the IP address, subnet mask, or gateway address manually, because the IP address is acquired from the DHCP server. | | | | | | | | | | | | | | | | | | | | | | | | | | | | | | | | | | |

Menu Settings

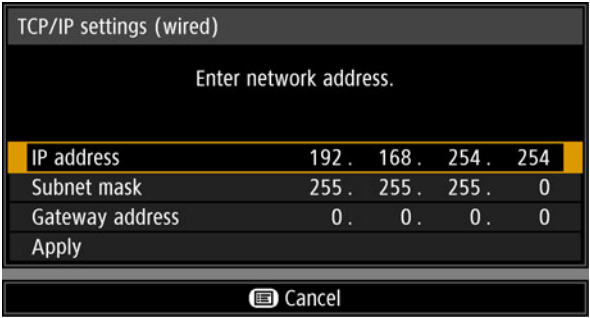
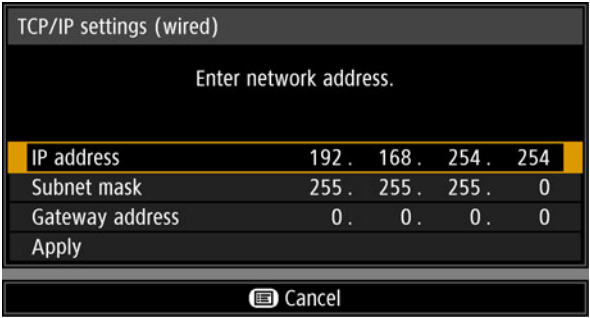
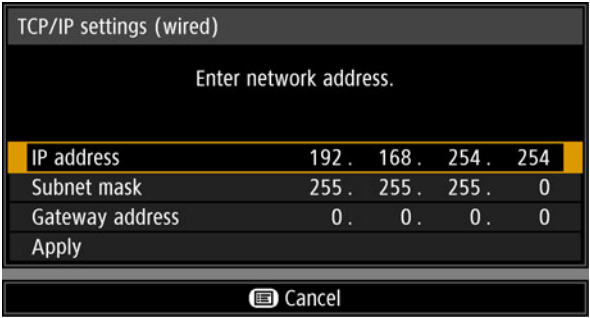
| Menu | Function | | | | | | | |
|--------------------------------|---|----------|----------|-----------------|--|----|---|--|
| Detailed IPv4 address settings | <table border="1"> <thead> <tr> <th data-bbox="389 171 577 229">Submenu</th> <th data-bbox="577 171 1219 229">Function</th> </tr> </thead> <tbody> <tr> <td data-bbox="389 229 577 1058">TCP/IP settings</td> <td data-bbox="577 229 1219 1058"> <p>Change or specify the IP address, subnet mask, and gateway address used for connections.</p>  <ul style="list-style-type: none"> • This menu is not available (grayed out) when [DHCP] (P143) is [On]. • If an invalid value is entered, “Invalid entry.” is displayed. In this case, enter a valid value. • When [Network (wired/wireless)] is set to [On/On (Pj AP)], “Cannot set identical segment IP” is displayed if you specify the same subnetwork as in PJ AP mode. Enter a different subnetwork, or change [Network (wired/wireless)] to [On/Off] before entering the wired IP address again. </td> </tr> </tbody> </table> | Submenu | Function | TCP/IP settings | <p>Change or specify the IP address, subnet mask, and gateway address used for connections.</p>  <ul style="list-style-type: none"> • This menu is not available (grayed out) when [DHCP] (P143) is [On]. • If an invalid value is entered, “Invalid entry.” is displayed. In this case, enter a valid value. • When [Network (wired/wireless)] is set to [On/On (Pj AP)], “Cannot set identical segment IP” is displayed if you specify the same subnetwork as in PJ AP mode. Enter a different subnetwork, or change [Network (wired/wireless)] to [On/Off] before entering the wired IP address again. | | | |
| | Submenu | Function | | | | | | |
| TCP/IP settings | <p>Change or specify the IP address, subnet mask, and gateway address used for connections.</p>  <ul style="list-style-type: none"> • This menu is not available (grayed out) when [DHCP] (P143) is [On]. • If an invalid value is entered, “Invalid entry.” is displayed. In this case, enter a valid value. • When [Network (wired/wireless)] is set to [On/On (Pj AP)], “Cannot set identical segment IP” is displayed if you specify the same subnetwork as in PJ AP mode. Enter a different subnetwork, or change [Network (wired/wireless)] to [On/Off] before entering the wired IP address again. | | | | | | | |
| IPv6 | <table border="1"> <thead> <tr> <th data-bbox="389 1058 577 1116">Option</th> <th data-bbox="577 1058 1219 1116">Function</th> </tr> </thead> <tbody> <tr> <td data-bbox="389 1116 577 1155">Off</td> <td data-bbox="577 1116 1219 1155">Disables the projector’s wired LAN (IPv6) function.</td> </tr> <tr> <td data-bbox="389 1155 577 1244">On</td> <td data-bbox="577 1155 1219 1244">Enables the projector’s wired LAN (IPv6) function. [Detailed IPv6 address settings] is now available.</td> </tr> </tbody> </table> | Option | Function | Off | Disables the projector’s wired LAN (IPv6) function. | On | Enables the projector’s wired LAN (IPv6) function. [Detailed IPv6 address settings] is now available. | |
| Option | Function | | | | | | | |
| Off | Disables the projector’s wired LAN (IPv6) function. | | | | | | | |
| On | Enables the projector’s wired LAN (IPv6) function. [Detailed IPv6 address settings] is now available. | | | | | | | |

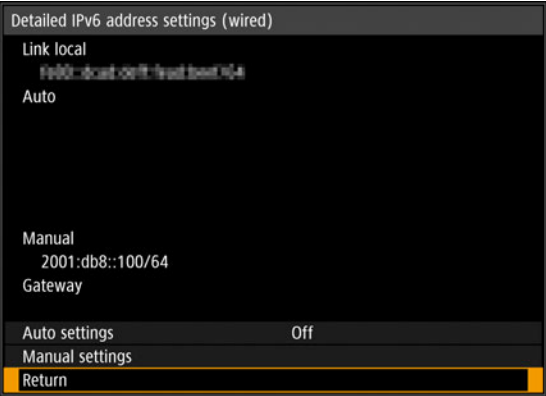
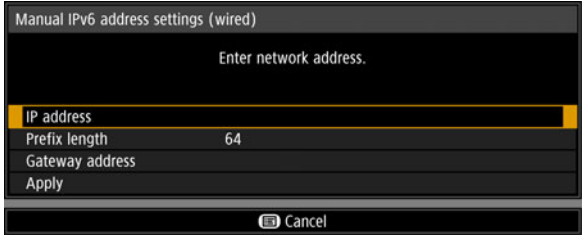
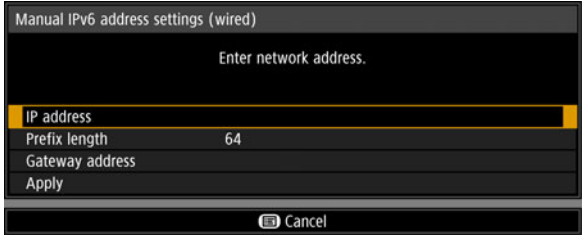
| Menu | Function | | | | | | | | | | | | | |
|---------------------------------------|---|---------|----------|------------|---|------|--|--------|---|---------|--|---------------|---|-----------------|
| <p>Detailed IPv6 address settings</p> | <p>Configure details of the projector's wired LAN (IPv6) function.</p>  | | | | | | | | | | | | | |
| | <table border="1"> <thead> <tr> <th data-bbox="408 651 578 683">Submenu</th> <th data-bbox="578 651 1204 683">Function</th> </tr> </thead> <tbody> <tr> <td data-bbox="408 683 578 722">Link local</td> <td data-bbox="578 683 1204 722">Link-local address of the wired LAN (IPv6).</td> </tr> <tr> <td data-bbox="408 722 578 761">Auto</td> <td data-bbox="578 722 1204 761">Automatic addresses (up to 5) of the wired LAN (IPv6).</td> </tr> <tr> <td data-bbox="408 761 578 799">Manual</td> <td data-bbox="578 761 1204 799">Manual address of the wired LAN (IPv6).</td> </tr> <tr> <td data-bbox="408 799 578 838">Gateway</td> <td data-bbox="578 799 1204 838">Gateway address of the wired LAN (IPv6).</td> </tr> <tr> <td data-bbox="408 838 578 909">Auto settings</td> <td data-bbox="578 838 1204 909">Enable/disable automatic address setting of the wired LAN (IPv6).</td> </tr> <tr> <td data-bbox="408 909 578 1464">Manual settings</td> <td data-bbox="578 909 1204 1464"> <p>Manually configure settings of the wired LAN (IPv6). Change or specify the IPv6 address, prefix length, and gateway address.</p>  <ul style="list-style-type: none"> • This menu is not available (grayed out) when [Auto settings] is [On]. • If an invalid value is entered, "Invalid entry." is displayed. In this case, enter a valid value. </td> </tr> </tbody> </table> | Submenu | Function | Link local | Link-local address of the wired LAN (IPv6). | Auto | Automatic addresses (up to 5) of the wired LAN (IPv6). | Manual | Manual address of the wired LAN (IPv6). | Gateway | Gateway address of the wired LAN (IPv6). | Auto settings | Enable/disable automatic address setting of the wired LAN (IPv6). | Manual settings |
| Submenu | Function | | | | | | | | | | | | | |
| Link local | Link-local address of the wired LAN (IPv6). | | | | | | | | | | | | | |
| Auto | Automatic addresses (up to 5) of the wired LAN (IPv6). | | | | | | | | | | | | | |
| Manual | Manual address of the wired LAN (IPv6). | | | | | | | | | | | | | |
| Gateway | Gateway address of the wired LAN (IPv6). | | | | | | | | | | | | | |
| Auto settings | Enable/disable automatic address setting of the wired LAN (IPv6). | | | | | | | | | | | | | |
| Manual settings | <p>Manually configure settings of the wired LAN (IPv6). Change or specify the IPv6 address, prefix length, and gateway address.</p>  <ul style="list-style-type: none"> • This menu is not available (grayed out) when [Auto settings] is [On]. • If an invalid value is entered, "Invalid entry." is displayed. In this case, enter a valid value. | | | | | | | | | | | | | |

| Menu | Function |
|--------------------------------|---|
| Network setting initialization | <p>The following network settings are initialized.</p> <p>Settings configured from the projector menu</p> <ul style="list-style-type: none"> • Network settings lock (P141) • Network password setting (P141) • Register network password (P141) • Network (wired/wireless) (P142) • Detailed settings (wired) (P142) <ul style="list-style-type: none"> - Detailed IPv4 address settings (P143) <ul style="list-style-type: none"> - IP address (wired LAN (IPv4)) (P143) - Subnet mask (wired LAN (IPv4)) (P143) - Gateway address (wired LAN (IPv4)) (P143) - DHCP (wired LAN (IPv4)) (P143) - TCP/IP settings (P144) - IPv6 (P144) - Detailed IPv6 address settings (P145) <ul style="list-style-type: none"> - Auto settings (P145) - Manual settings (P145) <ul style="list-style-type: none"> - IP address (wired LAN (IPv6)) (P145) - Prefix length (P145) - Gateway address (wired LAN (IPv6)) (P145) • PJLink (P152) • AMX Device Discovery settings (P153) • Crestron RoomView settings (P153) <p>Settings configured from the web screen</p> <ul style="list-style-type: none"> • [Password] (P163) • [Wired] (P170) <ul style="list-style-type: none"> - DHCP (P170) - IP address (P170) - Subnet mask (P170) - Default gateway (P170) • [Mail] (P174) • [SNMP] (P176) • [Projector info.] (P177) • [PJLink] (P177) • [Crestron] (P178) |

Detailed settings (wireless)

 > [Network settings] > **[Detailed settings (wireless)]**



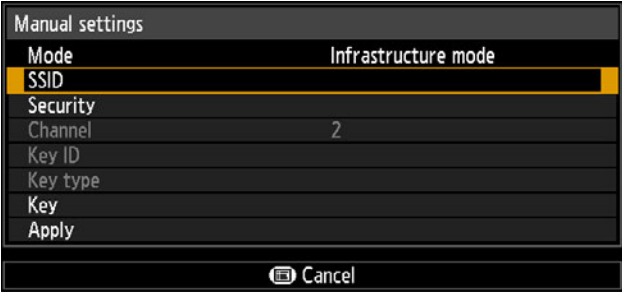
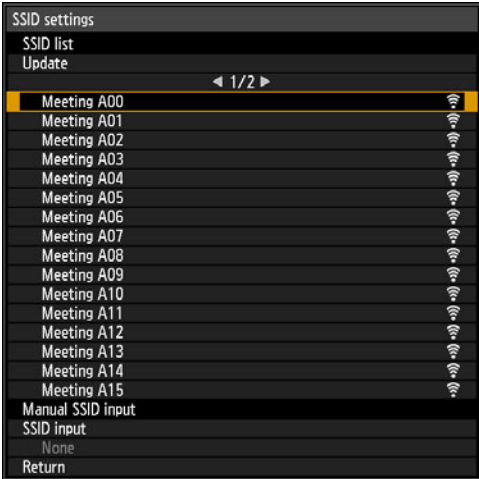
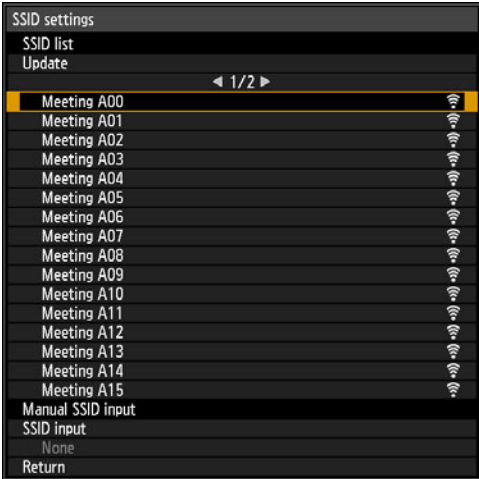
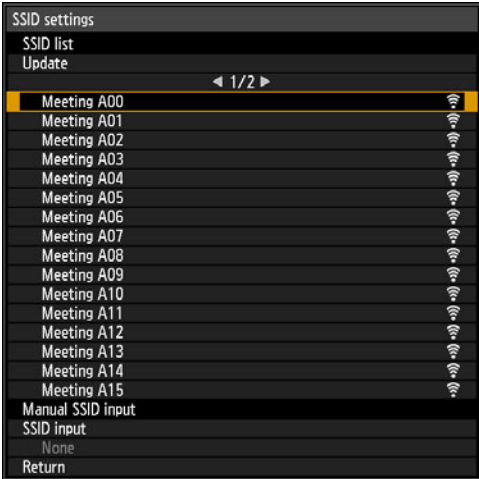

Display and manually change the wireless IP address, gateway address, and other settings. Available only when wireless networking is [On].

| Detailed settings (wireless) | |
|--------------------------------|---------------------|
| Mode | Infrastructure mode |
| SSID | |
| Security | WPA-PSK TKIP |
| Channel | 2 |
| Signal strength | 10dB |
| MAC address | 74:81:3d:0d:ef:01 |
| Wi-Fi Protected Setup | |
| Manual settings | |
| Detailed IPv4 address settings | |
| IPv6 | Off |
| Detailed IPv6 address settings | |
| Network setting initialization | |
| Return | |

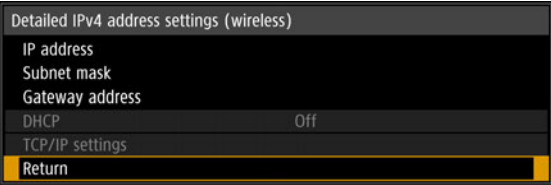
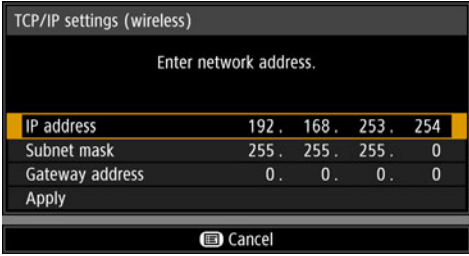
| Menu | Function | | | | | | |
|-----------------------|--|----------|----------|-----|--|-----|---|
| Mode | Shows the wireless connection mode. (P136) | | | | | | |
| SSID | Shows the access point SSID. | | | | | | |
| Security | Shows the security setting. | | | | | | |
| Channel | Shows the channel used for the connection. | | | | | | |
| Signal strength | Shows actual signal strength, as measured. | | | | | | |
| MAC address | Wireless MAC address of the projector. | | | | | | |
| Wi-Fi Protected Setup | Select the method of connection in infrastructure mode. | | | | | | |
| | <table border="1"> <thead> <tr> <th>Submenu</th> <th>Function</th> </tr> </thead> <tbody> <tr> <td>PBC</td> <td>Connect in PBC (push-button) mode. Following the instructions shown, press the button on the wireless base station (access point), and, within 2 minutes, select [OK] on the screen.</td> </tr> <tr> <td>PIN</td> <td>Connect in PIN mode. Following the instructions shown, enter the displayed 8-digit PIN code on the wireless base station (access point), and, within 10 minutes, select [OK] on the screen.</td> </tr> </tbody> </table> | Submenu | Function | PBC | Connect in PBC (push-button) mode. Following the instructions shown, press the button on the wireless base station (access point), and, within 2 minutes, select [OK] on the screen. | PIN | Connect in PIN mode. Following the instructions shown, enter the displayed 8-digit PIN code on the wireless base station (access point), and, within 10 minutes, select [OK] on the screen. |
| | Submenu | Function | | | | | |
| PBC | Connect in PBC (push-button) mode. Following the instructions shown, press the button on the wireless base station (access point), and, within 2 minutes, select [OK] on the screen. | | | | | | |
| PIN | Connect in PIN mode. Following the instructions shown, enter the displayed 8-digit PIN code on the wireless base station (access point), and, within 10 minutes, select [OK] on the screen. | | | | | | |
| | | | | | | | |

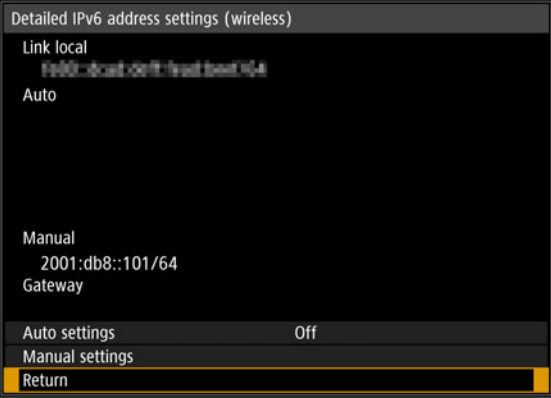
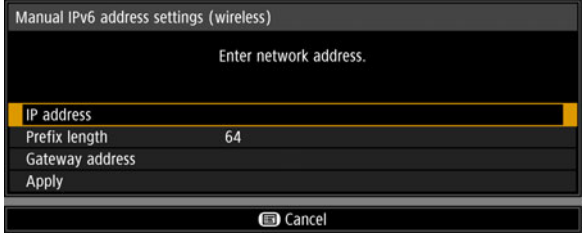
| Menu | Function | | | | | | | | | | | | | | | | | | |
|-----------------|--|--|----------|------|--|------|--|----------|---|---------|--|--------|---|----------|--|-----|---|-------|------------------------------------|
| Manual settings | <p>Manually specify the projector's wireless settings.</p>  | | | | | | | | | | | | | | | | | | |
| | <table border="1"> <thead> <tr> <th data-bbox="406 542 577 581">Submenu</th> <th data-bbox="577 542 1199 581">Function</th> </tr> </thead> <tbody> <tr> <td data-bbox="406 581 577 620">Mode</td> <td data-bbox="577 581 1199 620">Shows the wireless connection mode. (P136)</td> </tr> <tr> <td data-bbox="406 620 577 1209">SSID</td> <td data-bbox="577 620 1199 1209"> <p>A list of available access point SSIDs is displayed. You can find available access points nearby and change the name of the connection.</p>  </td> </tr> <tr> <td data-bbox="406 1209 577 1306">Security</td> <td data-bbox="577 1209 1199 1306">Select the wireless security from [Open], [WEP], [WPA2 AES], or [WPA/WPA2 TKIP/AES]. In PJ AP mode, choose from [Open] or [WPA2 AES].</td> </tr> <tr> <td data-bbox="406 1306 577 1344">Channel</td> <td data-bbox="577 1306 1199 1344">Shows the current wireless channel (1 - 11).</td> </tr> <tr> <td data-bbox="406 1344 577 1412">Key ID</td> <td data-bbox="577 1344 1199 1412">Select the wireless WEP key ID. Only available for when security is set to [WEP].</td> </tr> <tr> <td data-bbox="406 1412 577 1479">Key type</td> <td data-bbox="577 1412 1199 1479">Select the wireless security key input type. Not available when security is set to [Open].</td> </tr> <tr> <td data-bbox="406 1479 577 1576">Key</td> <td data-bbox="577 1479 1199 1576">Not available when security is set to [Open] or when wired/wireless networking is set to [On/On (Pj AP)] or [Off/On (Pj AP)].</td> </tr> <tr> <td data-bbox="406 1576 577 1634">Apply</td> <td data-bbox="577 1576 1199 1634">Connect with the current settings.</td> </tr> </tbody> </table> | Submenu | Function | Mode | Shows the wireless connection mode. (P136) | SSID | <p>A list of available access point SSIDs is displayed. You can find available access points nearby and change the name of the connection.</p>  | Security | Select the wireless security from [Open], [WEP], [WPA2 AES], or [WPA/WPA2 TKIP/AES]. In PJ AP mode, choose from [Open] or [WPA2 AES]. | Channel | Shows the current wireless channel (1 - 11). | Key ID | Select the wireless WEP key ID. Only available for when security is set to [WEP]. | Key type | Select the wireless security key input type. Not available when security is set to [Open]. | Key | Not available when security is set to [Open] or when wired/wireless networking is set to [On/On (Pj AP)] or [Off/On (Pj AP)]. | Apply | Connect with the current settings. |
| | Submenu | Function | | | | | | | | | | | | | | | | | |
| | Mode | Shows the wireless connection mode. (P136) | | | | | | | | | | | | | | | | | |
| | SSID | <p>A list of available access point SSIDs is displayed. You can find available access points nearby and change the name of the connection.</p>  | | | | | | | | | | | | | | | | | |
| | Security | Select the wireless security from [Open], [WEP], [WPA2 AES], or [WPA/WPA2 TKIP/AES]. In PJ AP mode, choose from [Open] or [WPA2 AES]. | | | | | | | | | | | | | | | | | |
| | Channel | Shows the current wireless channel (1 - 11). | | | | | | | | | | | | | | | | | |
| | Key ID | Select the wireless WEP key ID. Only available for when security is set to [WEP]. | | | | | | | | | | | | | | | | | |
| | Key type | Select the wireless security key input type. Not available when security is set to [Open]. | | | | | | | | | | | | | | | | | |
| Key | Not available when security is set to [Open] or when wired/wireless networking is set to [On/On (Pj AP)] or [Off/On (Pj AP)]. | | | | | | | | | | | | | | | | | | |
| Apply | Connect with the current settings. | | | | | | | | | | | | | | | | | | |

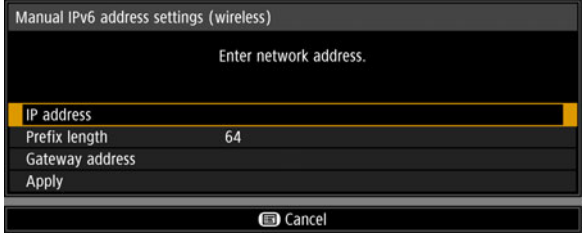
| Menu | Function | | | | | | | | | | | | | | |
|---------------------------------------|--|----------|----------|------------|--|-------------|--|-----------------|---|--------|----------|-----|---|----|--|
| <p>Detailed IPv4 address settings</p> | <p>Configure details of the projector's wireless LAN (IPv4) function.</p>  <table border="1" data-bbox="408 446 1197 624"> <thead> <tr> <th>Submenu</th> <th>Function</th> </tr> </thead> <tbody> <tr> <td>IP address</td> <td>IP address of the projector's wireless LAN (IPv4).</td> </tr> <tr> <td>Subnet mask</td> <td>Subnet mask of the projector's wireless LAN (IPv4).</td> </tr> <tr> <td>Gateway address</td> <td>Gateway address of the projector's wireless LAN (IPv4).</td> </tr> </tbody> </table> <p>DHCP</p> <p>Enable or disable wireless DHCP on the projector.</p> <table border="1" data-bbox="594 678 1181 975"> <thead> <tr> <th>Option</th> <th>Function</th> </tr> </thead> <tbody> <tr> <td>Off</td> <td>Disables the DHCP function. TCP/IP settings can be configured manually.</td> </tr> <tr> <td>On</td> <td>Enables the DHCP function. Searches the DHCP server. It will no longer be possible to enter the IP address, subnet mask, or gateway address manually, because the IP address is acquired from the DHCP server.</td> </tr> </tbody> </table> <p>TCP/IP settings</p> <p>Configure the projector's wireless TCP/IP settings.</p> <div data-bbox="594 1045 1181 1213" style="background-color: #f0f0f0; padding: 5px;"> <ul style="list-style-type: none"> • This menu is not available (grayed out) when [DHCP] is [On]. • If an invalid value is entered, "Invalid entry." is displayed. In this case, enter a valid value. </div>  | Submenu | Function | IP address | IP address of the projector's wireless LAN (IPv4). | Subnet mask | Subnet mask of the projector's wireless LAN (IPv4). | Gateway address | Gateway address of the projector's wireless LAN (IPv4). | Option | Function | Off | Disables the DHCP function. TCP/IP settings can be configured manually. | On | Enables the DHCP function. Searches the DHCP server. It will no longer be possible to enter the IP address, subnet mask, or gateway address manually, because the IP address is acquired from the DHCP server. |
| | Submenu | Function | | | | | | | | | | | | | |
| IP address | IP address of the projector's wireless LAN (IPv4). | | | | | | | | | | | | | | |
| Subnet mask | Subnet mask of the projector's wireless LAN (IPv4). | | | | | | | | | | | | | | |
| Gateway address | Gateway address of the projector's wireless LAN (IPv4). | | | | | | | | | | | | | | |
| Option | Function | | | | | | | | | | | | | | |
| Off | Disables the DHCP function. TCP/IP settings can be configured manually. | | | | | | | | | | | | | | |
| On | Enables the DHCP function. Searches the DHCP server. It will no longer be possible to enter the IP address, subnet mask, or gateway address manually, because the IP address is acquired from the DHCP server. | | | | | | | | | | | | | | |
| <p>IPv6</p> | <table border="1" data-bbox="408 1541 1197 1682"> <thead> <tr> <th>Option</th> <th>Function</th> </tr> </thead> <tbody> <tr> <td>Off</td> <td>Disables the projector's wireless LAN (IPv6) function.</td> </tr> <tr> <td>On</td> <td>Enables the projector's wireless LAN (IPv6) function. [Detailed IPv6 address settings] is now available.</td> </tr> </tbody> </table> | Option | Function | Off | Disables the projector's wireless LAN (IPv6) function. | On | Enables the projector's wireless LAN (IPv6) function. [Detailed IPv6 address settings] is now available. | | | | | | | | |
| Option | Function | | | | | | | | | | | | | | |
| Off | Disables the projector's wireless LAN (IPv6) function. | | | | | | | | | | | | | | |
| On | Enables the projector's wireless LAN (IPv6) function. [Detailed IPv6 address settings] is now available. | | | | | | | | | | | | | | |

| Menu | Function | | | | | | | | | | | | | |
|---------------------------------------|--|---------|----------|------------|--|------|---|--------|--|---------|---|---------------|--|-----------------|
| <p>Detailed IPv6 address settings</p> | <p>Configure details of the projector's wireless LAN (IPv6) function.</p>  | | | | | | | | | | | | | |
| | <table border="1"> <thead> <tr> <th data-bbox="408 653 578 685">Submenu</th> <th data-bbox="578 653 1199 685">Function</th> </tr> </thead> <tbody> <tr> <td data-bbox="408 685 578 726">Link local</td> <td data-bbox="578 685 1199 726">Link-local address of the wireless LAN (IPv6).</td> </tr> <tr> <td data-bbox="408 726 578 795">Auto</td> <td data-bbox="578 726 1199 795">Automatic addresses (up to 5) of the wireless LAN (IPv6).</td> </tr> <tr> <td data-bbox="408 795 578 836">Manual</td> <td data-bbox="578 795 1199 836">Manual address of the wireless LAN (IPv6).</td> </tr> <tr> <td data-bbox="408 836 578 877">Gateway</td> <td data-bbox="578 836 1199 877">Gateway address of the wireless LAN (IPv6).</td> </tr> <tr> <td data-bbox="408 877 578 944">Auto settings</td> <td data-bbox="578 877 1199 944">Enable/disable automatic address setting of the wireless LAN (IPv6).</td> </tr> <tr> <td data-bbox="408 944 578 1495">Manual settings</td> <td data-bbox="578 944 1199 1495"> <p>Manually configure settings of the wireless LAN (IPv6). Change or specify the IPv6 address, prefix length, and gateway address.</p>  <div style="border: 1px solid gray; padding: 5px; margin-top: 10px;">  <ul style="list-style-type: none"> This menu is not available (grayed out) when [Auto settings] is [On]. If an invalid value is entered, "Invalid entry." is displayed. In this case, enter a valid value. </div> </td> </tr> </tbody> </table> | Submenu | Function | Link local | Link-local address of the wireless LAN (IPv6). | Auto | Automatic addresses (up to 5) of the wireless LAN (IPv6). | Manual | Manual address of the wireless LAN (IPv6). | Gateway | Gateway address of the wireless LAN (IPv6). | Auto settings | Enable/disable automatic address setting of the wireless LAN (IPv6). | Manual settings |
| Submenu | Function | | | | | | | | | | | | | |
| Link local | Link-local address of the wireless LAN (IPv6). | | | | | | | | | | | | | |
| Auto | Automatic addresses (up to 5) of the wireless LAN (IPv6). | | | | | | | | | | | | | |
| Manual | Manual address of the wireless LAN (IPv6). | | | | | | | | | | | | | |
| Gateway | Gateway address of the wireless LAN (IPv6). | | | | | | | | | | | | | |
| Auto settings | Enable/disable automatic address setting of the wireless LAN (IPv6). | | | | | | | | | | | | | |
| Manual settings | <p>Manually configure settings of the wireless LAN (IPv6). Change or specify the IPv6 address, prefix length, and gateway address.</p>  <div style="border: 1px solid gray; padding: 5px; margin-top: 10px;">  <ul style="list-style-type: none"> This menu is not available (grayed out) when [Auto settings] is [On]. If an invalid value is entered, "Invalid entry." is displayed. In this case, enter a valid value. </div> | | | | | | | | | | | | | |

| Menu | Function |
|--------------------------------|--|
| Network setting initialization | <p>The following network settings are initialized.</p> <p>Settings configured from the projector menu</p> <ul style="list-style-type: none"> • Network settings lock (P141) • Network password setting (P141) • Register network password (P141) • Network (wired/wireless) (P142) • Detailed settings (wireless) (P147) <ul style="list-style-type: none"> - Detailed IPv4 address settings (P149) <ul style="list-style-type: none"> - TCP/IP settings (P149) - IP address (wireless LAN (IPv4)) (P149) - Subnet mask (wireless LAN (IPv4)) (P149) - Gateway address (wireless LAN (IPv4)) (P149) - DHCP (wireless LAN (IPv4)) (P149) - IPv6 (P149) <ul style="list-style-type: none"> - Detailed IPv6 address settings (P150) <ul style="list-style-type: none"> - Auto settings (P150) - Manual settings (P150) <ul style="list-style-type: none"> - IP address (wireless LAN (IPv6)) (P150) - Prefix length (P150) - Gateway address (wireless LAN (IPv6)) (P150) <p>Settings configured from the web screen</p> <ul style="list-style-type: none"> • [Password] (P163) • [Wireless] (P172) <ul style="list-style-type: none"> - DHCP (P172) - IP address (P172) - Subnet mask (P172) - Default gateway (P172) • [Mail] (P174) • [Mail auth] (P175) • [Projector info.] (P177) |

PJLink



> [Network settings] > [PJLink]

You can enable or disable the PJLink network function of the projector.

When the function is turned on, control is possible via the network using commands that meet PJLink standards.

| Option | Function |
|--------|-------------------------------|
| Off | Disables the PJLink function. |
| On | Enables the PJLink function. |



- The projector conforms to Class 1 as defined in PJLink standards established by the Japan Business Machine and Information System Industries Association (JBMIA). This projector supports all commands that are defined by PJLink Class 1, and has been verified as conforming to the PJLink standard Class 1 definition.
- For details on using PJLink, see “Setting PJLink [PJLink]” (P177).

What is PJLink?

In September 2003, the PJLink Working Group was established under the Data Projector Committee. During the first year, this PJLink Working Group standardized PJLink as a new interface specification for projectors.

PJLink is a unified standard for operation and control of projectors.

It allows centralized control of projectors and operation from a controller for all projectors regardless of manufacturer.

The objective is for JBMIA to improve convenience for users and expand the use of projectors through early systemization for network monitoring and control of projectors, which will become the mainstream in the future.

Class 1: Standardization of control and monitoring specifications for basic projector functions

Basic projector control: Power control, input selection, etc.

Acquisition of projector information and status: Power status, input selection status, error status, etc.

JBMIA: Japan Business Machine and Information System Industries Association.

The JBMIA is an organization which was launched in 1960 and changed its name on April 1, 2002.

PJLink website: <http://pjlink.jbmia.or.jp/english/>



PJLink is a registered trademark of JBMIA and pending trademark in some countries.

PJLink is a registered trademark, or an application has been submitted for trademark, in Japan, the United States and / or other countries or regions.

AMX Device Discovery

 > [Network settings] > **[AMX Device Discovery]**

This setting enables other equipment compatible with AMX Device Discovery to detect the projector over a network. For networks without AMX Device Discovery, select [Off].

| Option | Function |
|--------|---|
| Off | Disables AMX Device Discovery. |
| On | Enables AMX Device Discovery. The projector will periodically send out AMX beacon packets over the network. |



- For details on AMX Device Discovery, visit the AMX website.
<http://www.amx.com/>

Crestron RoomView

 > [Network settings] > **[Crestron RoomView]**

Crestron RoomView enables centralized management of multiple projectors over a network. Networked projectors can be remotely controlled to troubleshoot issues, or turn the projectors on or off. Specify whether to use Crestron RoomView.

| Option | Function |
|--------|--|
| Off | Disable Crestron RoomView. |
| On | Enables Crestron RoomView. A port for RoomView will be opened, and the projector will respond to CIP packets. Communication is possible via the RoomView Express/Server application or via Crestron Controller. (P178) |



- For details on Crestron RoomView, visit the Crestron® website.
<http://www.crestron.com/>

Information



> [Network settings] > **[Information]**

Shows network information.

| Menu | | Function | |
|---------------------------------|------|--|---|
| E-mail sender address | | Sender e-mail address for sending error messages. (P174) | |
| E-mail recipient address | | [Already set] or [Not set] is shown, indicating whether a recipient e-mail address has been set for error messages. (P174) | |
| Detailed information (wired) | IPv4 | IP address of the wired LAN (IPv4). | |
| | IPv6 | Link local | Link-local IP address of the wired LAN (IPv6). |
| | | Auto | Automatic IP address of the wired LAN (IPv6). |
| | | Manual | Manual IP address of the wired LAN (IPv6). |
| Detailed information (wireless) | IPv4 | IP address of the wireless LAN (IPv4). | |
| | IPv6 | Link local | Link-local IP address of the wireless LAN (IPv6). |
| | | Auto | Automatic IP address of the wireless LAN (IPv6). |
| | | Manual | Manual IP address of the wireless LAN (IPv6). |



- Detailed information (wired) is displayed when [Network (wired/wireless)] is set to [On/*].
- Detailed information (wireless) is displayed when [Network (wired/wireless)] is set to [*/On].

Checking Projector Information

You can check information about the signal types of the images projected and other information.

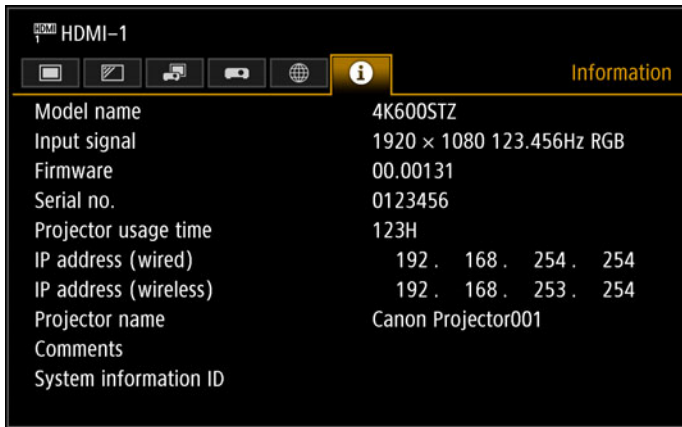

| Menu | Function |
|------------------------|---|
| Model name | Shows the model name. |
| Input signal | Details of the input signal currently selected Information such as the type, resolution, frequency, and color format of the signal is displayed. |
| Firmware | Current firmware version |
| Serial no. | Serial number unique to this projector |
| Projector usage time | Shows the total time the projector has been on. |
| IP address (wired)* | IP address for wired connections. |
| IP address (wireless)* | IP address for wireless connections. |
| Projector name* | Name which identifies this projector on the network |
| Comments* | Comments such as the location in which the projector is installed are displayed. (P177) |
| System information ID | System information. Normally this is not displayed. |

* No value is displayed when [Network (wired/wireless)] is set to [Off/Off].
Some values may not be displayed, depending on [Network (wired/wireless)] settings. (○: displayed, ×: not displayed)

| Network (wired/wireless) | Off/Off | On/Off | On/On (Pj AP) | Off/On (Pj AP) | Off/On (Infra) |
|--------------------------|---------|--------|---------------|----------------|----------------|
| IP address (wired) | × | ○ | ○ | × | × |
| IP address (wireless) | × | × | ○ | ○ | ○ |
| Projector name | × | ○ | ○ | ○ | ○ |
| Comments | × | ○ | ○ | ○ | ○ |

Completing Computer Settings for a Network Connection

Specifying an IP Address

Instructions for setting a computer's IP address (for wired connections or wireless connections) are as follows for each operating system.

■ Windows 10

- 1 Right-click the Start button (Windows logo) in the lower left of the screen.**
 - In desktop mode (from the desktop screen)
The same operation is possible by pressing Win+X.
- 2 In the shortcut menu displayed in the lower left, click [Control Panel].**
- 3 Click [View network status and tasks].**
 - In Icon View:
Click [Network and Sharing Center].
- 4 Click [Change adapter settings].**
- 5 For a wired connection, right-click [Ethernet], or for a wireless connection, right-click [Wi-Fi]. Next, click [Properties].**
- 6 In the [This connection uses the following items] list, select [Internet Protocol Version 4 (TCP/IPv4)] and click the [Properties] button. Make a note of the original network settings (IP address, subnet mask, default gateway, etc).**
- 7 Select [Use the following IP address] and set the IP address and subnet mask.**

The projector's own default IP address is "192.168.254.254" for wired connections and "192.168.253.254" for wireless connections. Specify a different IP address.
- 8 When finished, click the [OK] button, and then click the [Close] button in the [Ethernet Properties] window to close it.**

■ Windows 8.1 / Windows 8

- 1 Right-click on the start screen background and click [All Apps] in the lower right.**
 - Windows 8.1 Users:
Click the down arrow in the lower left of the start screen.
- 2 Click [Control Panel].**
 - From the Desktop:
Press Win+X.
In the shortcut menu displayed in the lower left, click [Control Panel].
- 3 Click [View network status and tasks].**
 - In Icon View:
Click [Network and Sharing Center].
- 4 Click [Change adapter settings].**
- 5 For a wired connection, right-click [Ethernet], or for a wireless connection, right-click [Wi-Fi]. Next, click [Properties].**
- 6 In the [This connection uses the following items] list, select [Internet Protocol Version 4 (TCP/IPv4)] and click the [Properties] button. Make a note of the original network settings (IP address, subnet mask, default gateway, etc).**
- 7 Select [Use the following IP address] and set the IP address and subnet mask.**

The projector's own default IP address is "192.168.254.254" for wired connections and "192.168.253.254" for wireless connections. Specify a different IP address.
- 8 When finished, click the [OK] button, and then click the [Close] button in the [Ethernet Properties] window to close it.**

■ Windows 7

- 1** From the PC [Start] menu, select [Control Panel].
- 2** Click on [Network and Internet], then click on [View network status and tasks].
- 3** From the menu on the left side of the window, click on [Change adapter settings].
- 4** For a wired connection, right-click [Local Area Connection], or for a wireless connection, right-click [Wireless Network Connection]. Next, click [Properties].
- 5** Select [Internet Protocol Version 4 (TCP/IPv4)] and click the [Properties] button. Make a note of the original network settings (IP address, subnet mask, default gateway, etc).
- 6** Select [Use the following IP address] and set the IP address and subnet mask.
The projector's own default IP address is "192.168.254.254" for wired connections and "192.168.253.254" for wireless connections. Specify a different IP address.
- 7** When the settings are completed, click the [OK] button and then click the [OK] button on the [Local Area Connection Properties] window to close it.

■ Windows Vista

- 1** From the PC [Start] menu, select [Control Panel].
- 2** Click on [View network status and tasks].
- 3** From the menu on the left side of the window, click on [Manage network connections].
- 4** For a wired connection, right-click [Local Area Connection], or for a wireless connection, right-click [Wireless Network Connection]. Next, click [Properties].
- 5** Select [Internet Protocol Version 4 (TCP/IPv4)] and click the [Properties] button. Make a note of the original network settings (IP address, subnet mask, default gateway, etc).
- 6** Select [Use the following IP address] and set the IP address and subnet mask.
The projector's own default IP address is "192.168.254.254" for wired connections and "192.168.253.254" for wireless connections. Specify a different IP address.
- 7** When the settings are completed, click the [OK] button and then click the [OK] button on the [Local Area Connection Properties] window to close it.

■ Mac OS X

- 1** Open the Apple Menu and select [System Preferences].
- 2** In the System Preferences window, click [Network] to display the Network window.
- 3** For a wired connection, select [Built-in Ethernet], or for a wireless connection, select [Wi-Fi]. Next, click the [TCP/IP] tab. Make a note of the original network settings (IP address, subnet mask, router, DNS server, and so on).
- 4** Create a new network environment and set the IP address and subnet mask.
The projector's own default IP address is "192.168.254.254" for wired connections and "192.168.253.254" for wireless connections. Specify a different IP address.
- 5** Click [Apply] to close the network preference window.

■ Resetting the IP Address Setting of the Computer

Follow the same procedure as for changing the IP address and reset the values to the original values based on the notes taken before the change.

Setting Up the Network

■ Displaying the Network Configuration Screen

1 Turn on the computer and projector.

 Network functions are not available for the first 40 seconds after projector startup.

2 Launch a web browser, enter “http://(projector IP address)” in the address bar, and press the Enter key.

The projector web screen appears.

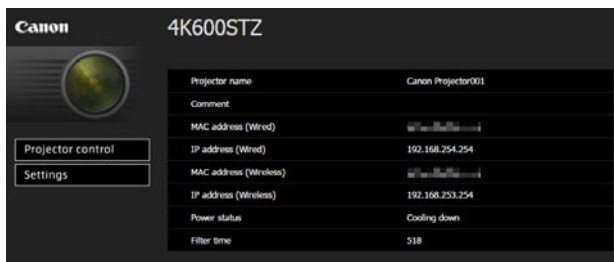

The following information is displayed.

| | |
|------------------------|--|
| Projector control | Displays the projector control screen. |
| Settings | Shows the settings screen. |
| Projector name | The name of the projector on the network |
| Comment | Relevant notes, such as where the projector is installed |
| MAC address (Wired) | MAC address of the wired LAN |
| IP address (Wired) | IP address of the wired LAN (IPv4) |
| MAC address (Wireless) | MAC address of the wireless LAN |
| IP address (Wireless) | IP address of the wireless LAN (IPv4) |
| Power status | The power status of the projector |
| Filter time | Air filter operating time |
| Alert | Error message (if an error has occurred) Temperature abnormality Light source abnormality Faulty air filter unit Faulty cooling fan Faulty power supply |

 The factory default IP address is “192.168.254.254” for wired connections (IPv4) and “192.168.253.254” for wireless connections (IPv4). If DHCP settings are used, ask the network administrator for the projector IP address. It is possible to check the IP address from the projector menu. (P143, P149)

3 Click [Settings] on the web screen.

The password input window appears.

4 Enter the user name and password on the password input window, then click [OK].

The factory default user name is “root” and the password is “system”.

The settings screen is displayed. Complete the network settings on this screen.

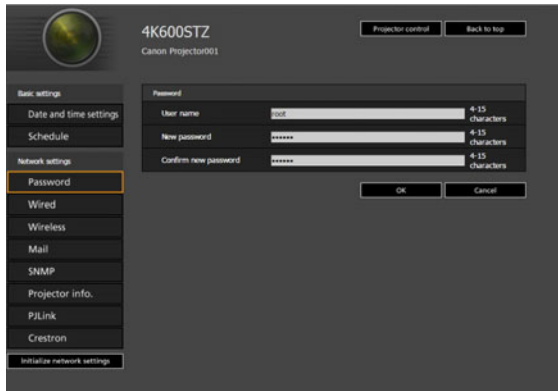

To control the projector from the computer, click [Projector control]. (P181)

■ Network Setting

1 Select a function to set up from the settings screen menu.

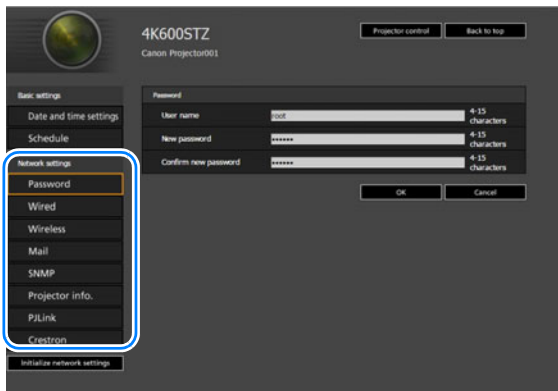

Using the Projector on a Network

2 Enter setting details in the fields shown (1), and then click [OK] (2).

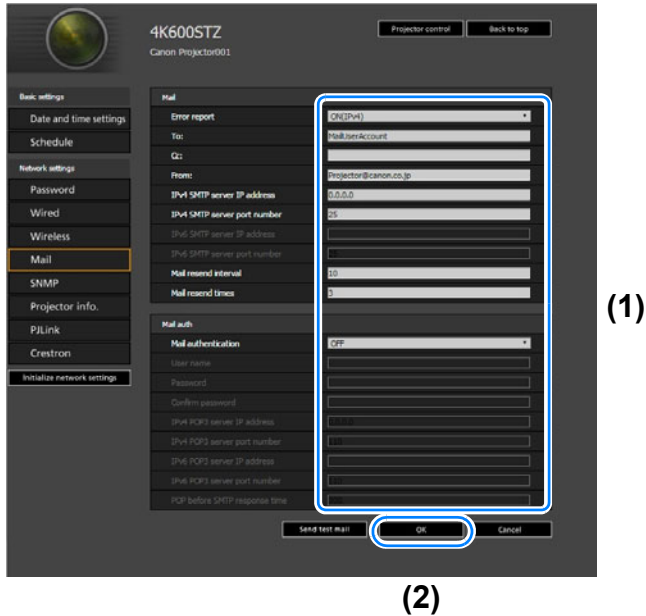

3 A confirmation window appears. Check the contents and if they are correct, click [Apply].

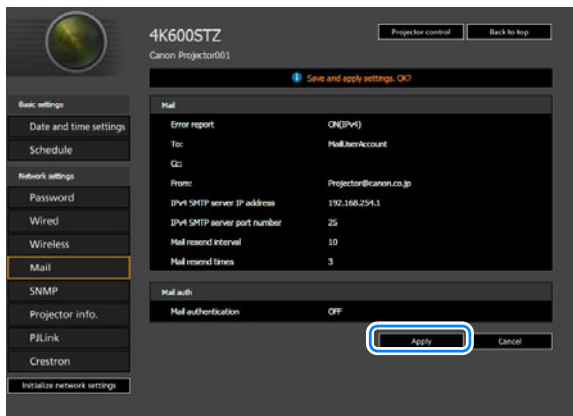

The settings are applied to the projector.

Selecting [Wired], [Wireless] or [Password] in the menu will cause this message to be displayed: “Save completed. Please change setting and reconnect.”

If you select functions other than above, “Save completed” is displayed. Click [Back to top] to return to the top page of the web screen.



Setting a Password [Password]

From [Password] in the settings screen, you can set a user name and password for web screen login. For the setting procedure, refer to “Network Setting” (P161).

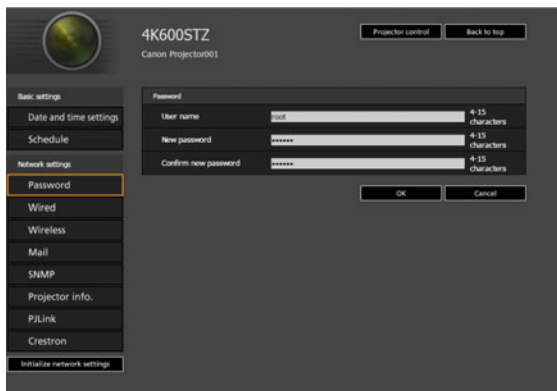

| Item | Explanation | Factory default setting |
|----------------------|---|-------------------------|
| User name | When logging into the web screen, enter the user name in 1-byte alphanumeric characters and symbols (4 -15 characters). | root |
| New password | When logging into the web screen, enter the password in 1-byte alphanumeric characters and symbols (4 -15 characters). | system |
| Confirm new password | For confirmation, enter the same password that you entered in [New password]. | system |

Setting the Date and Time [Date and time settings]

From [Date and time settings] in the settings screen, you can set time settings such as the current date and time, date/time display format, time zone, and daylight saving time. For the setting procedure, refer to “Network Setting” (P161).



| | Item | Explanation | Factory default setting |
|------------|------------------|---|------------------------------|
| Day & Time | Day | Enter the date in 1-byte numbers. | 2017/01/01 |
| | Indication order | Choose [YYYY/MM/DD], [MM/DD/YYYY], or [DD/MM/YYYY] as the date display format. | YYYY/MM/DD |
| | Time | Enter the time in 1-byte numbers, in the range 00:00:00 to 23:59:59. | 00:00:00 |
| | Time zone | Select a city in your time zone. | (GMT) Dublin, Lisbon, London |
| | SNTP | Select whether to turn the SNTP (Simple Network Time Protocol) function on or off. Choosing ON (IPv4) will prevent you from configuring the following settings. [Day] [Time] [IPv6 SNTP server IP address] Choosing ON (IPv6) will prevent you from configuring the following settings. [Day] [Time] [IPv4 SNTP server IP address] | OFF |

| Item | | Explanation | Factory default setting |
|-------------------|--|---|-------------------------|
| Day & Time | IPv4 SNTP server IP address | Enter the IPv4 SNTP server IP address in 1-byte numbers. | 0.0.0.0 |
| | IPv6 SNTP server IP address | Enter the IPv6 SNTP server IP address in 1-byte numbers. | <Blank> |
| Summer Time | ON / OFF | Select whether to turn on or off time adjustment one hour ahead at the beginning of daylight saving time and one hour back at the end. Choosing OFF will prevent you from configuring the following settings. [Start point Month] [Start point Week] [Start point Day] [Start point Time] [Finish point Month] [Finish point Week] [Finish point Day] [Finish point Time] | OFF |
| | Start point Month | Select the month when daylight saving time begins. | 1 |
| | Start point Week | Select the week when daylight saving time begins. | 1 |
| | Start point Day | Select the day when daylight saving time begins. | Mon |
| | Start point Time | Enter the starting time for daylight saving time in 1-byte numbers, in the range 00:00 to 23:59. | 00:00 |
| | Finish point Month | Select the month when daylight saving time ends. | 1 |
| | Finish point Week | Select the week when daylight saving time ends. | 1 |
| | Finish point Day | Select the day when daylight saving time ends. | Mon |
| Finish point Time | Enter the ending time for daylight saving time in 1-byte numbers, in the range 00:00 to 23:59. | 00:00 | |

Setting a Scheduling [Schedule]

From [Schedule] in the settings screen, you can automate some projector tasks by scheduling them. As the timing of scheduled operation, choose from [Usually], which is not during a certain period, or one of five special period times (Period.1 – Period.5) that you set up. For the setting procedure, refer to “Network Setting” (P161).

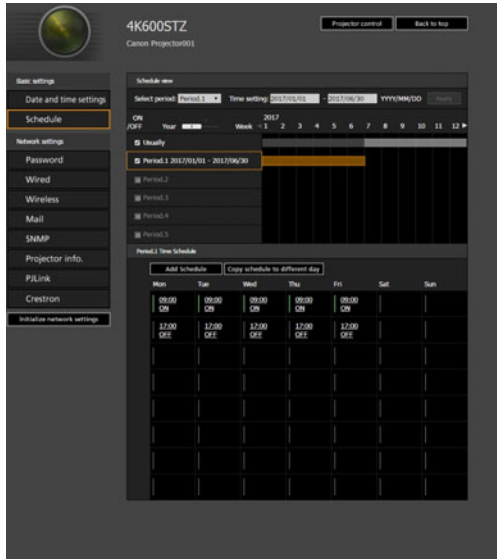

| | Item | Explanation | Factory default setting |
|---------------|---------------|--|-------------------------|
| Schedule view | Select period | Select a specific period to configure. | Period.1 |
| | Time setting | In the left box, enter the starting date of the specific period you are scheduling, and in the right box, enter the ending date, using 1-byte numbers. Dates of periods cannot be set to overlap. | 2017/01/01 |
| | Usually | Shows the usual schedule, which can be turned on or off by selecting the check boxes. | Cleared (OFF) |

| | Item | Explanation | Factory default setting |
|---------------|---------------|--|-------------------------|
| Schedule view | Period.1 | Shows the timing of the scheduled period 1. Can be turned on or off by selecting the check box. | Cleared (OFF) |
| | Period.2 | Shows the timing of the scheduled period 2. Can be turned on or off by selecting the check box. | Cleared (OFF) |
| | Period.3 | Shows the timing of the scheduled period 3. Can be turned on or off by selecting the check box. | Cleared (OFF) |
| | Period.4 | Shows the timing of the scheduled period 4. Can be turned on or off by selecting the check box. | Cleared (OFF) |
| | Period.5 | Shows the timing of the scheduled period 5. Can be turned on or off by selecting the check box. | Cleared (OFF) |
| | Time Schedule | Shows times and days of the week of the usual schedule or period schedule selected in [Schedule view]. Green vertical line: projector on; gray vertical line: projector off; blue vertical line: switch input signals. Up to 8 schedules can be set per day. | — |

Clicking an item in [Time Schedule] displays the [Edit schedule] screen, enabling you to edit the schedule of the selected day or time.

Edit schedule
 Day: Mon
 Time: 09:00 hh:mm
 Operation: Power
 Parameter: ON
 Delete OK Cancel

Using the Projector on a Network

| | Item | Explanation | Factory default setting |
|---------------|-----------|---|-------------------------|
| Edit schedule | Day | Shows the day of the week for the selected schedule. | — |
| | Time | Enter the automatic execution time in 1-byte numbers, in the range 00:00 to 23:59. | <Blank> |
| | Operation | As the operation for automatic execution, choose [Power], [Input], or [Calibration]. | Power |
| | Parameter | As parameters for automatic execution, choose from the following options. <ul style="list-style-type: none"> • When [Operation] is set to [Power]: ON / OFF • When [Operation] is set to [Input]: DVI-1 / DVI-2 / DVI-3 / DVI-4 / HDMI-1 / HDMI-2 / DVI 1x4 / DVI 2x2 / DVI 1x2 / HDMI 1x2 • When [Operation] is set to [Calibration]: LIGHT | ON |

Clicking [Add schedule] in [Time Schedule] displays the [Add schedule] screen, enabling you to add a new schedule to the selected usual schedule or period schedule.

The screenshot shows the 'Add schedule' dialog box with the following settings:

- Day:** Mon, Tue, Wed, Thu, Fri, Sat, Sun (all checkboxes are unchecked)
- Time:** (empty text field) hh:mm
- Operation:** Power
- Parameter:** ON

| | Item | Explanation | Factory default setting |
|--------------|-----------|---|-------------------------|
| Add schedule | Day | Select a day of the week for automatic execution. Multiple days can be selected. | Cleared |
| | Time | Enter the automatic execution time in 1-byte numbers, in the range 00:00 to 23:59. | <Blank> |
| | Operation | As the operation for automatic execution, choose [Power], [Input], or [Calibration]. | Power |
| | Parameter | As parameters for automatic execution, choose from the following options. <ul style="list-style-type: none"> When [Operation] is set to [Power]: ON / OFF When [Operation] is set to [Input]: DVI-1 / DVI-2 / DVI-3 / DVI-4 / HDMI-1 / HDMI-2 / DVI 1x4 / DVI 2x2 / DVI 1x2 / HDMI 1x2 When [Operation] is set to [Calibration]: LIGHT | ON |

Clicking [Copy schedule to different day] in [Time Schedule] displays the [Schedule copy] screen, enabling you to copy a schedule to any day for the selected usual schedule or period schedule.

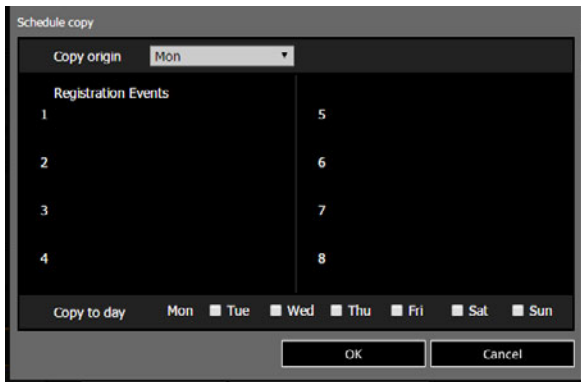

| | Item | Explanation | Factory default setting |
|---------------|---------------------|---|-------------------------|
| Schedule copy | Copy origin | Select the day to copy from. | Mon |
| | Registration Events | Shows schedule details on the selected day. | <Blank> |
| | Copy to day | Select the day to copy to. Multiple days can be selected. | Cleared |

Basic Wired Network Settings [Wired]

From [Wired] on the settings screen, you can complete basic network information for wired connections. For the setting procedure, refer to “Network Setting” (P161).

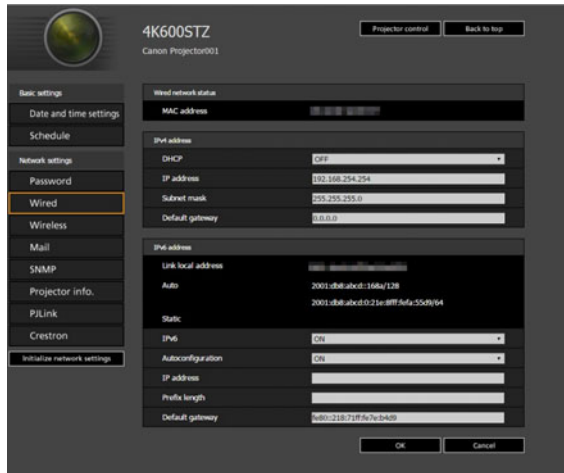

| Item | | Explanation | Factory default setting |
|--------------|-----------------|---|-----------------------------------|
| MAC address | | Shows the projector's wired MAC address. | The projector's wired MAC address |
| IPv4 address | DHCP | Select whether to turn the DHCP function on or off for wired LAN (IPv4). The following settings cannot be configured manually when this setting is [ON], because the IP address is acquired from the DHCP server. [IP address] [Subnet mask] [Default gateway] | OFF |
| | IP address | Enter the projector's wired LAN (IPv4) IP address in 1-byte numbers. | 192.168.254.254 |
| | Subnet mask | Enter the wired LAN (IPv4) subnet mask in 1-byte numbers. | 255.255.255.0 |
| | Default gateway | Enter the wired LAN (IPv4) default gateway address in 1-byte numbers. | 0.0.0.0 |

| | Item | Explanation | Factory default setting |
|--------------|-------------------|---|-------------------------|
| IPv6 address | IPv6 | Specify on or off for the IPv6 function of the wired LAN (IPv6). Choosing OFF will prevent you from configuring the following settings. [Autoconfiguration] [IP address] [Prefix length] [Default gateway] | OFF |
| | Autoconfiguration | Select on or off for the auto setting function of the wired LAN (IPv6). Choosing ON will prevent you from configuring the following settings. [IP address] [Prefix length] [Default gateway] | OFF |
| | IP address | Enter the wired LAN (IPv6) address in 1-byte numbers. | <Blank> |
| | Prefix length | Enter the wired LAN (IPv6) prefix length in 1-byte numbers. | <Blank> |
| | Default gateway | Enter the wired LAN (IPv6) default gateway address in 1-byte numbers. | <Blank> |



If settings related to TCP/IP were changed, it is necessary to disconnect and reconnect to the network.

If the network subnet mask was changed, select [Subnet mask] in the above screen and set the new subnet mask.

Basic Wireless Network Settings [Wireless]

From [Wireless] on the settings screen, you can complete basic network information for wireless connections. For the setting procedure, refer to “Network Setting” (P161).

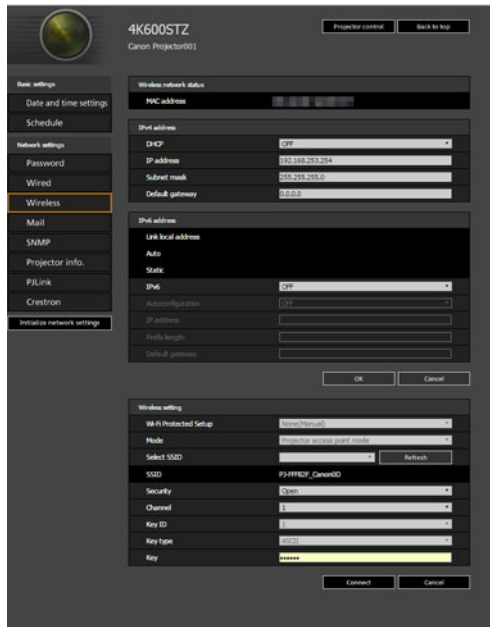

| Item | | Explanation | Factory default setting |
|--------------|-----------------|--|--------------------------------------|
| MAC address | | Shows the projector's wireless MAC address. | The projector's wireless MAC address |
| IPv4 address | DHCP | Select whether to turn the DHCP function on or off for wireless LAN (IPv4). The following settings cannot be configured manually when this setting is [ON], because the IP address is acquired from the DHCP server. [IP address] [Subnet mask] [Default gateway] | OFF |
| | IP address | Enter the projector's wireless LAN (IPv4) IP address in 1-byte numbers. | 192.168.253.254 |
| | Subnet mask | Enter the wireless LAN (IPv4) subnet mask in 1-byte numbers. | 255.255.255.0 |
| | Default gateway | Enter the wireless LAN (IPv4) default gateway address in 1-byte numbers. | 0.0.0.0 |

| | Item | Explanation | Factory default setting |
|--------------|-------------------|---|---|
| IPv6 address | IPv6 | Specify on or off for the wireless LAN (IPv6) function. Choosing OFF will prevent you from configuring the following settings. [Autoconfiguration] [IP address] [Prefix length] [Default gateway] | OFF |
| | Autoconfiguration | Select on or off for the auto setting function of the wireless LAN (IPv6). Choosing ON will prevent you from configuring the following settings. [IP address] [Prefix length] [Default gateway] | OFF |
| | IP address | Enter the wireless LAN (IPv6) IP address in 1-byte numbers. | <Blank> |
| | Prefix length | Enter the wireless LAN (IPv6) prefix length in 1-byte numbers. | <Blank> |
| | Default gateway | Enter the wireless LAN (IPv6) default gateway address in 1-byte numbers. | <Blank> |
| | Wireless setting | Wi-Fi Protected Setup | Select a simple method of establishing a wireless connection. |
| Mode | | Select the wireless connection mode. | infrastructure mode |
| Select SSID | | Select the wireless access point's SSID. Click the [Refresh] button to update the list. If the SSID is not listed, enter it in 1-byte alphanumeric characters (1-32 characters). | <Blank> |
| Security | | Select the wireless security setting. | Open |
| Channel | | Shows the wireless channel number. When [Mode] is set to projector access point (PJ AP) mode, a channel can be selected. | 1 |
| Key ID | | Select the wireless WEP key ID. | 1 |
| Key type | | Select the wireless security key input type. | ASCII |

Using the Projector on a Network

| | Item | Explanation | Factory default setting |
|------------------|------|----------------------------------|-------------------------|
| Wireless setting | Key | Enter the wireless security key. | <Blank> |



If settings related to TCP/IP were changed, it is necessary to disconnect and reconnect to the network. If the network subnet mask was changed, select [Subnet mask] in the above screen and set the new subnet mask.

Setting Up Email [Mail]

From [Mail] in the settings screen, you can set the items necessary to send error mails and test mails. For the setting procedure, refer to “Network Setting” (P161).

The screenshot shows the 'Mail' settings page for a Canon projector. The page is titled '4K600STZ' and 'Canon Projector001'. It features a sidebar with navigation options like 'Basic settings', 'Date and time settings', 'Schedule', 'Network settings', 'Password', 'Wired', 'Wireless', 'Mail', 'SNMP', 'Projector info.', 'PiLink', 'Crestion', and 'Initialize network settings'. The 'Mail' section is active, showing fields for 'Error report' (set to 'On(SMTP)'), 'To:' (MailUserAccount), 'Cc:', 'From:' (Projector@canon.co.jp), 'IPv4 SMTP server IP address' (0.0.0.0), 'IPv4 SMTP server port number' (25), 'IPv6 SMTP server IP address', 'IPv6 SMTP server port number', 'Mail resend interval' (10), and 'Mail resend times' (3). Below these are 'Mail auth' settings, including 'Mail authentication' (OFF), 'User name', 'Password', 'Confirm password', 'IPv4 POP3 server IP address', 'IPv4 POP3 server port number', 'IPv6 POP3 server IP address', 'IPv6 POP3 server port number', and 'POP before SMTP response time'. At the bottom, there are buttons for 'Send test mail', 'OK', and 'Cancel'.

| Item | Explanation | Factory default setting |
|------------------------------|--|-------------------------|
| Error report | Select whether to turn the error mail sending function on or off, and IPv4 or IPv6 for the network to use. | OFF |
| To: | Enter the recipient address for error mails in 1-byte alphanumeric characters and symbols (1 - 63 characters). | MailUserAccount |
| Cc: | Enter the CC address for error mails in 1-byte alphanumeric characters and symbols (1 - 63 characters). | <Blank> |
| From: | Enter the sender address for error mails in 1-byte alphanumeric characters and symbols (1 - 63 characters). | Projector@canon.co.jp |
| IPv4 SMTP server IP address | Enter the SMTP server IP address (IPv4) in 1-byte numbers. | 0.0.0.0 |
| IPv4 SMTP server port number | Enter the SMTP server port number (IPv4) in 1-byte numbers (1 - 65535). | 25 |

| Item | Explanation | Factory default setting |
|------------------------------|---|-------------------------|
| IPv6 SMTP server IP address | Enter the SMTP server IP address (IPv6) in 1-byte numbers. | <Blank> |
| IPv6 SMTP server port number | Enter the SMTP server port number (IPv6) in 1-byte numbers (1 - 65535). | 25 |
| Mail resend interval* | Enter the interval for resending mail when an error occurred (unit: seconds) within the range of 0 - 59 seconds using 1-byte numbers. | 10 |
| Mail resend times | Enter the number of times to resend mail when an error occurred within the range of 0 - 255 using 1-byte numbers. | 3 |

* When the interval is set to 0 seconds, repeated attempts to send mail are made (as set in [Mail resend times]) without pausing between attempts.

Mail Authentication Settings

From [Mail auth] under [Mail] in the settings screen, you can configure the settings for authentication of mail that is sent when an error occurs. For the setting procedure, refer to “Network Setting” (P161).

| Item | Explanation | Factory default setting |
|-------------------------------|---|-------------------------|
| Mail authentication | Select the mail authentication method. If OFF is selected, the other mail authentication settings cannot be changed. | OFF |
| User name | Enter the user name to use for mail authentication in 1-byte alphanumeric characters and symbols (1 - 63 characters). | <Blank> |
| Password | Enter the password for mail authentication in 1-byte alphanumeric characters and symbols (1 - 63 characters). | <Blank> |
| Confirm password | For confirmation, enter the same password as you entered in [Password]. | <Blank> |
| IPv4 POP3 server IP address | Enter the POP3 server IP address (IPv4) in 1-byte numbers. | 0.0.0.0 |
| IPv4 POP3 server port number | Enter the POP3 server port number (IPv4) in 1-byte numbers (1 - 65535). | 110 |
| IPv6 POP3 server IP address | Enter the POP3 server IP address (IPv6) in 1-byte numbers. | <Blank> |
| IPv6 POP3 server port number | Enter the POP3 server port number (IPv6) in 1-byte numbers (1 - 65535). | 110 |
| POP before SMTP response time | Enter the SMTP authentication timeout period after POP3 authentication (unit: milliseconds) using 1-byte numbers (0 - 9999 milliseconds). | 300 |

Sending a Test Mail

You can send a test mail to the mail address specified in [Mail] under [Mail] in the settings screen by clicking [Send test mail] at the bottom of the screen.

SNMP Settings [SNMP]

From [SNMP] in the settings screen, you can configure the settings related to control of projectors which use SNMP (Simple Network Management Protocol). For the setting procedure, refer to “Network Setting” (P161).

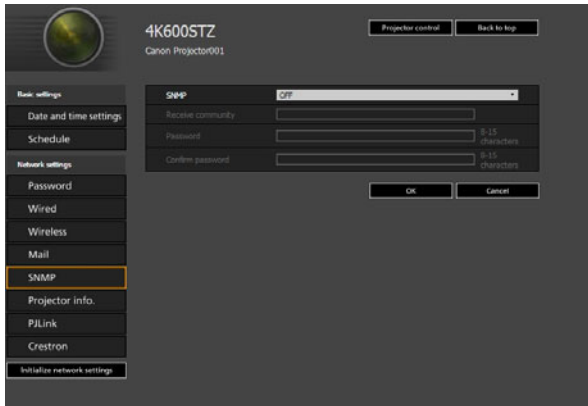

| Item | Explanation | Factory default setting |
|-------------------|--|-------------------------|
| SNMP | Select the SNMP function version. If OFF is selected, the SNMP function will be turned off and the other settings in this screen cannot be configured. | OFF |
| Receive community | Enter the community name which will receive projector information in 1-byte alphanumeric characters and symbols (1 - 15 characters). | <Blank> |
| Password | Enter the community settings password in 1-byte alphanumeric characters and symbols (8 - 15 characters). It can be set only when the SNMP version is V3. | <Blank> |
| Confirm password | For confirmation, enter the same password as you entered in [Password]. | <Blank> |

Setting Projector Information [Projector info.]

From [Projector info.] in the settings screen, you can enter relevant comments such as projector names and locations where projectors are installed so that the information can be used to identify projectors when multiple projectors are installed on the network. For the setting procedure, refer to “Network Setting” (P161).

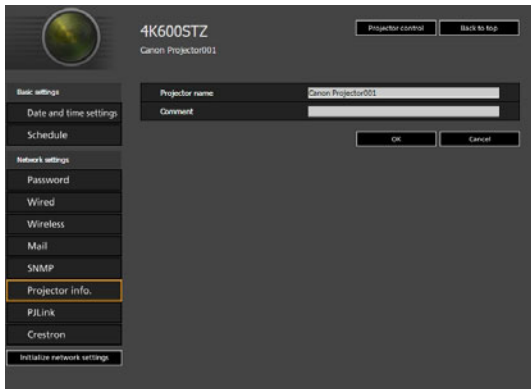

| Item | Explanation | Factory default setting |
|----------------|---|-------------------------|
| Projector name | Enter the projector name in 1-byte alphanumeric characters and symbols (1 - 63 characters). | Canon Projector001 |
| Comment | Enter any relevant notes, such as where the projector is installed. | <Blank> |



Some characters such as # cannot be used for [Projector name] and [Comment].

Setting PJLink [PJLink]

From [PJLink] in the settings screen, you can set the PJLink functions which are the standard for projector management on a network. For the setting procedure, refer to “Network Setting” (P161). For information about PJLink, refer to “What is PJLink?” (P152).

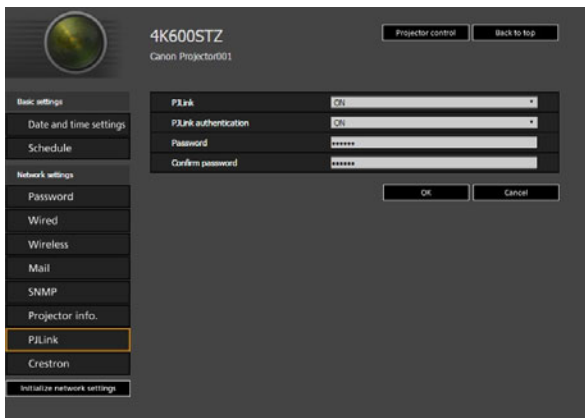

Using the Projector on a Network

| Item | Explanation | Factory default setting |
|-----------------------|--|-------------------------|
| PJLink | Turn the PJLink function on or off. If OFF is selected, the PJLink function will be turned off and the other settings in this screen cannot be configured. | ON |
| PJLink authentication | Select whether to turn the PJLink authentication function on or off. If OFF is selected, it is not possible to change the following items. [Password] [Confirm password] | ON |
| Password | Enter the PJLink authentication password in 1-byte alphanumeric characters (1 - 32 characters). | system |
| Confirm password | For confirmation, enter the same password that you entered in [Password]. | system |

Setting Up a Controller Manufactured by Crestron Electronics [Crestron Controller]

The [Crestron e-Control] screen will open. For details on the Crestron Controller, visit the Crestron website.

<http://www.crestron.com/>

Setting Errors

When a setting-related error occurs, the error name is displayed on the screen, and a “” mark is displayed next to the input field which caused the error.

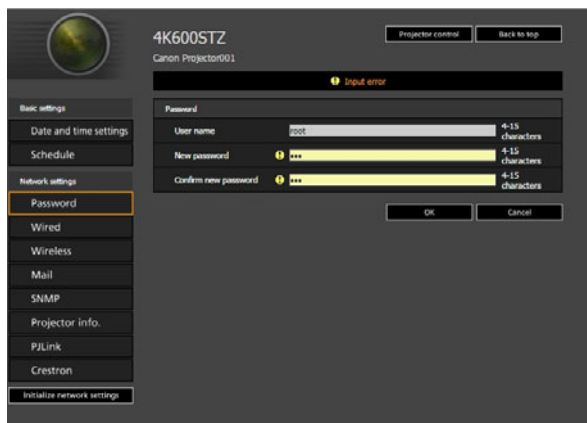

The error meanings are as shown below.

| Error | Meaning |
|------------------------|---|
| Input error | A setting outside the valid range was set on the settings screen. |
| Password setting error | The set password and confirmation password did not match. |
| Invalid SMTP | The SMTP server IP address has not been set. |

| Error | Meaning |
|--|---|
| System failed to connect SMTP server. | Failed to connect to the SMTP server when sending a test mail. |
| System failed to connect POP3 server. | Failed to connect to the POP3 server attempting to send a test mail. |
| System doesn't support this auth type. | An authentication type was set which is not supported by the server. |
| System failed to authenticate. | Authentication failed attempting to send a test mail. |
| The system failed to send the test mail. | Sending of test mail failed due to a connection failure with the SMTP server or an error which does not ordinarily occur. |

Resetting Network Settings to the Default Settings

- 1 Perform steps 1 - 3 on “Displaying the Network Configuration Screen” (P160) to display the settings screen.
- 2 Click [Initialize network settings].

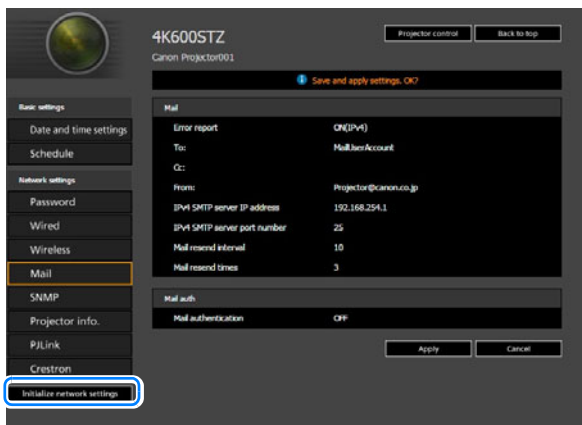

- 3 A confirmation window appears. Click [OK].

■ Error Notification Mails

The messages shown in the following error list are sent when an error occurs in the projector.

Error list

| | | |
|------------------------------------|------------|--|
| Errors related to temperature | Error name | Temperature abnormality |
| | Text | The internal temperature of the projector is abnormally high, or else the ambient air temperature exceeds the threshold. If the problem is with the projector, verify that it is properly installed and is being used correctly, and let the inside of the projector cool down for a while with the power plug disconnected from the wall outlet before resuming projection. Remove any objects that are blocking the air intake or exhaust vent. If the air filter is clogged, try cleaning or replacing it. If the same warning is displayed again, the main unit may be faulty. Please contact your dealer. |
| Errors related to the light source | Error name | Light source abnormality |
| | Text | The light source unit or a related component may be faulty. With the power off, disconnect the power plug from the wall outlet, wait for a while, and then plug it in again and turn the power back on. If the same warning is displayed again, please contact your dealer. |
| Errors related to the air filter | Error name | Faulty air filter unit |
| | Text | The air filter is incorrectly installed, or a related component may be faulty. With the power off, re-install the air filter correctly, then turn the power back on. If the same warning is displayed again, please contact your dealer. |
| Errors related to the fan | Error name | Faulty cooling fan |
| | Text | The cooling fan or a related component may be faulty. With the power off, disconnect the power plug from the wall outlet, and then plug it in again and turn the power back on. If the same warning is displayed again, please contact your dealer. |
| Errors related to the power | Error name | Faulty power supply |
| | Text | The power supply voltage may be abnormal, or a related component may be faulty. With the power off, disconnect the power plug from the wall outlet, and then plug it in again and turn the power back on. If the same warning is displayed again, please contact your dealer. |

Controlling the Projector from a Computer

The projector can be controlled from a computer over a wired or wireless network connection.

- 1 Turn on the computer and projector.
- 2 Launch a web browser, enter “http://(projector IP address)” in the address bar, and press the Enter key.

The projector web screen appears.



The factory default IP address is “192.168.254.254” for wired connections and “192.168.253.254” for wireless connections. If DHCP settings are used, ask the network administrator for the projector IP address. It is possible to check the IP address from the projector menu.

- 3 Click [Projector control] on the web screen.

The password input window appears.

- 4 Enter the user name and password on the password input window, then click [OK].

The factory default user name is “root” and the password is “system”.

Using the default user name and password unchanged opens up the risk of unauthorized operation of the projector by a malicious third party.

To enhance security, it is highly recommended that you change the user name and password. (P163)

The projector control screen appears.

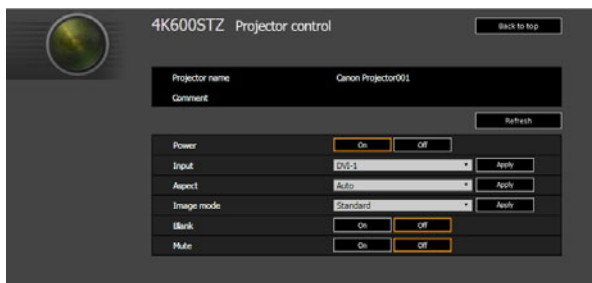

The projector can be controlled from this screen.

| Item | Explanation |
|----------------|--|
| Projector name | The name of the connected projector is displayed. (P177) |
| Comment | Shows notes, such as where the projector is installed. (P177) |
| Refresh | Refreshes the displayed contents with the most recent information. |
| Power | Turns projector power on or off. |
| Input | Select an input signal and click [Apply] to change to that input signal. (P55) |
| Aspect | Select an aspect and click [Apply] to change to that aspect. (P64) |
| Image mode | Select an image mode and click [Apply] to change to that image mode. (P68) |
| Blank | Switches the blank setting on or off. (P72) |

Using the Projector on a Network

| Item | Explanation |
|-------------|---|
| Mute | Switches the mute setting on or off. (P34) |
| Information | Shows the results of control, or control error information, at the top of the screen. |

- 5** When the operations are finished, click [Back to top] to return the initial web screen.

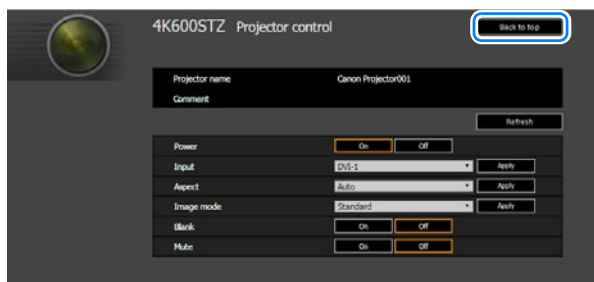

Projecting from Multiple Projectors at Once (Edge Blending)

The brightness of overlapping image edges from multiple projectors used together can be adjusted to make them blend in better.

■ Basic Instructions

Follow these steps when using two projectors side by side.

- 1 In the [Install settings] menu, select [Professional settings] > [Edge blending] > [Adjust].**



- If you have already completed edge blending settings, selecting [Adjust] will apply them.
- To redo adjustment from the beginning, select [Reset].

- 2 Set [Marker] to [On].**

Marker lines are projected on the images. The red marker indicates the start position for adjustment, and the green marker, the end position.

| Edge blending | | |
|---------------------------|-------|----------------|
| Side | Width | Start position |
| Left | 0 | 0 |
| Right | 0 | 0 |
| Top | 0 | 0 |
| Bottom | 0 | 0 |
| | | |
| Color blending adjustment | Off | |
| Black level adjustment | Off | |
| Marker | Off | |
| Reset | | |
| Return | | |



- By default, the green and red markers are displayed in the same position, so only the red marker is visible.

- 3 Adjust [Start position] for the side where images overlap. Move the start marker to the outer edge of the overlapping area, or press a number button on the remote control to specify the start position.**
- 4 Adjust [Width]. Move the end marker to the inner edge of the overlapping area, or press a number button on the remote control to specify the width of the area to correct.**

The area between the starting and ending markers is called the blending area. Values indicated for this blending area are adjusted to match manually entered blending area values. Shading is applied to this area, and the brightness is adjusted to match portions that overlap with other areas. After you complete settings for one image, do the same thing for the other one to specify the blending area. Adjust the settings to make the blending area for each image the same.

- 5 Set [Marker] to [Off].**

■ Color Adjustment

In overlapping projection, portions of images in the overlapping area that pick up other colors or are miscolored may be more noticeable. You can make this overlapping area appear less distracting by performing Color blending adjustment.

- 1** In the [Install settings] menu, select [Professional settings] > [Edge blending] > [Adjust] > [Color blending adjustment] > [Adjust].
- 2** As you watch the image, adjust the value to eliminate unwanted colors in the overlapping area.



First adjust red, green, and blue together by changing the [White] value, and then adjust [Red], [Green], and [Blue] values individually.

- 3** Repeat this adjustment on all projectors.

■ Black Level Adjustment

In overlapping projection, dark colors are projected with less intensity than other colors in the overlapping area. You can make this overlapping area less distracting by adjusting the black level of non-overlapping image areas.

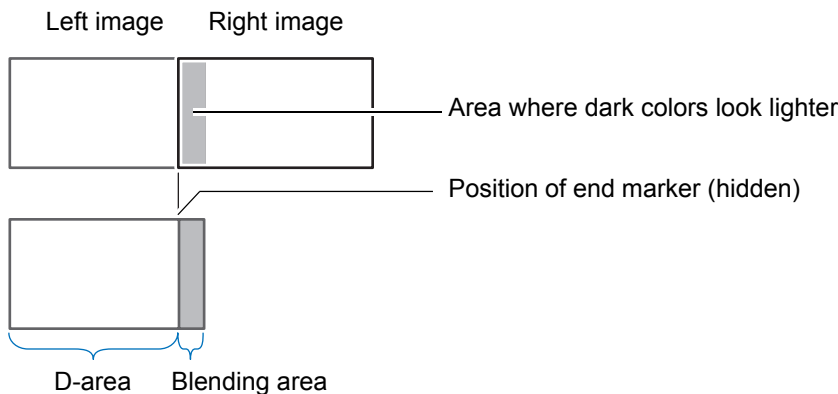

Here, the non-overlapping image area (from the end marker toward the center of the image) is called area “D.”

Normally, three areas are identified in the context of end markers: A, B, and C. In the following instructions, only area D is adjusted, and the widths of A, B, and C are left at the default value of 0.



To prepare for adjustment, set [No signal screen] to [Black], start projection with no input signal, and turn off the room lights, so that you can check dark image areas. (P118)

- 1 In the [Install settings] menu, select [Professional settings] > [Edge blending] > [Adjust] > [Black level adjustment] > [Adjust].
- 2 Select [Adjustment type] > [Black level].
- 3 After selecting [D-area base], as you watch the image, adjust the values so that the brightness and colors of the blending area and area D match.

| Black level adjustment | |
|------------------------|-------------|
| Adjustment type | Black level |
| B-area base | 0 |
| B-area red | +0 |
| B-area green | +0 |
| B-area blue | +0 |
| D-area base | 0 |
| D-area red | +0 |
| D-area green | +0 |
| D-area blue | +0 |
| Return | |

Adjust [D-area base] to lighten the black level, and adjust [Red], [Green], and [Blue] to obtain an optimal black level color tone, as needed.

- 4 Repeat this adjustment on all projectors.

■ Smoother Overlapping Areas

The black level along the right edge of area D (along the blending area) may be more noticeable than that of surrounding areas.

By adjusting the black level of area B, you can make the transition smoother.

To compensate, adjust each area as follows.

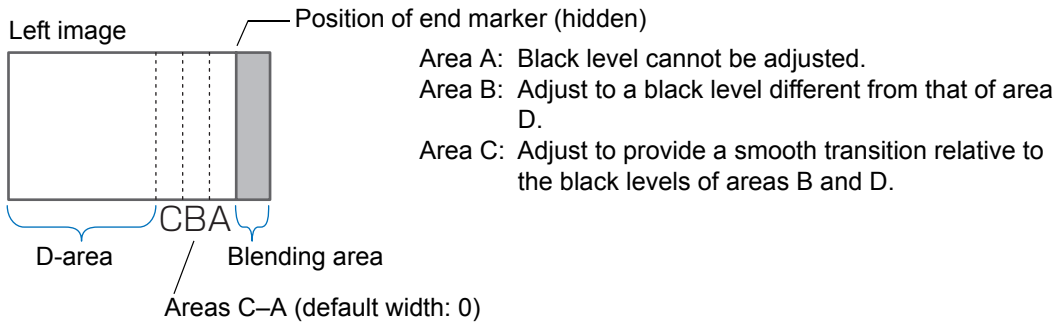

When the projected image has multiple blending areas (on the top, bottom, and each side), the width of areas A, B, and C must be adjusted to suit these blending areas.

In this example, instructions are given for adjusting area B.

- 1 In the [Install settings] menu, select [Professional settings] > [Edge blending] > [Adjust] > [Black level adjustment] > [Adjust].
- 2 Select [Adjustment type] > [Area] > [Side] > [Right].

3 Select [B-width], and then specify the width of area B.

Adjust the width of area B so that it roughly matches the area where the black level of area B stands out. This will make the width of area D narrower.



4 Select [Adjustment type] > [Black level]. Adjust [B-area base] as you watch the image.



- Results of adjusting the black level of area B are applied to all sides.
- Blending can be fine-tuned by adjusting [Adjustment type] > [Black level] > [Red], [Green], and [Blue].

5 As you watch the image, adjust the width of areas A, B, and C.

6 Readjust the black level of area B, as needed.

To reduce distracting colors and colors that are out of alignment in areas where the images overlap, perform [Color blending adjustment] targeting the main tone in the envisaged projected image.



- If you perform adjustments using [Color blending adjustment] or other menus, that may not eliminate the distracting colors and differences in brightness in areas where the images overlap.

Advanced Registration to Adjust Projected Images

This feature enables precise correction of red, green, or blue misalignment in different areas of the screen by color and area.

Two methods of registration are available: 5-point adjustment (using points in the corners and center of the screen) and more precise manual adjustment based on 54 points (in a 6 x 9 grid).

Any values you set in 5-point adjustment are retained if you subsequently perform manual adjustment. For more precise correction after 5-point adjustment, perform manual adjustment.



- Adjust zoom and lens shift as needed before using [Advanced registration].
- Performing keystone adjustment will prevent accurate adjustment with [Advanced registration]. If keystone adjustment is required, complete adjustment with [Advanced registration] first.

■ Registration Using 5-Point Adjustment

5-point adjustment enables basic correction of color misalignment across the screen, by moving adjustment points in each corner and the center.

- 1** In the [Install settings] menu, select [Professional settings] > [RGB alignment] > [Advanced registration] > [Adjust] > [5-point adjustment] > [Adjust].

The projector enters 5-point adjustment mode, and a chart is displayed.



- Charts (point selection windows) of two different sizes are used, depending on the [Panel drive mode] setting.
- With advanced registration, checkered or halftone image areas may be affected by uneven colors or image artifacts.

Advanced Projection

- 2 Use the [▲] / [▼] / [◀] / [▶] buttons to select the point for correction, and then press the OK button.

The projector enters color selection mode.

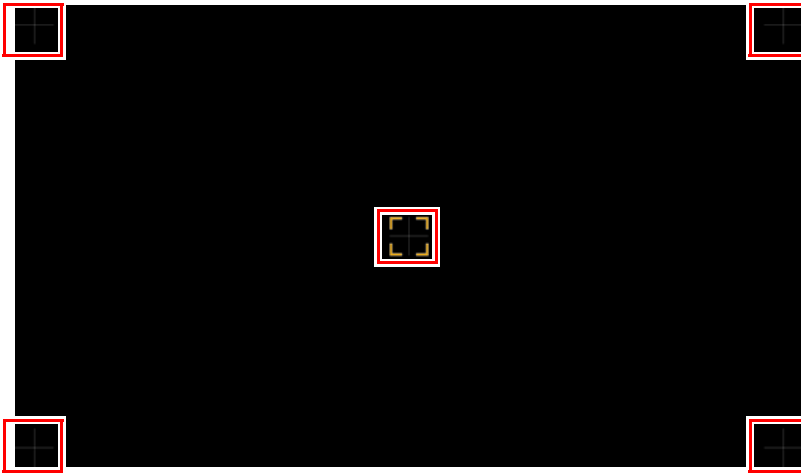

Press the **MENU** button to return to [Advanced registration].

- 3 Select [Red] or [Blue] as the color, and then press the OK button.



- Each time you select [Chart] and press the **OK** button, display switches between the chart and the source signal.
- Accessing the 5-point adjustment window during test pattern projection will show the test pattern instead of your supplied signal.

- 4 Use the [▲] / [▼] / [◀] / [▶] buttons to align the adjustment points.



- 5 Press the OK button to return to the window for color selection mode.
- 6 Repeat this process to align the remaining colors and adjustment points.

Manual Registration

Use manual adjustment to correct registration only in certain areas.



Any manual adjustment values set before switching to 5-point adjustment are cleared.

- 1 In the [Install settings] menu, select [Professional settings] > [RGB alignment] > [Advanced registration] > [Adjust] > [Manual adjustment]. The projector enters manual adjustment mode, and a chart is displayed.

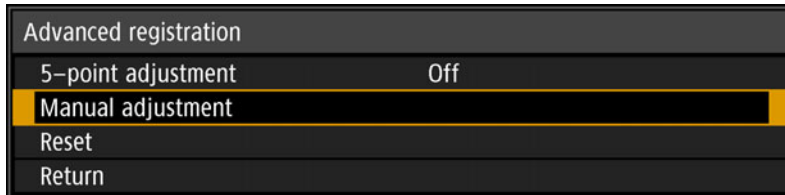

- Charts (point selection windows) of two different sizes are used, depending on the [Panel drive mode] setting.
- With advanced registration, checkered or halftone image areas may be affected by uneven colors or image artifacts.

- 2 Use the [▲] / [▼] / [◀] / [▶] buttons to select the point for correction, and then press the OK button.

The projector enters color selection mode.

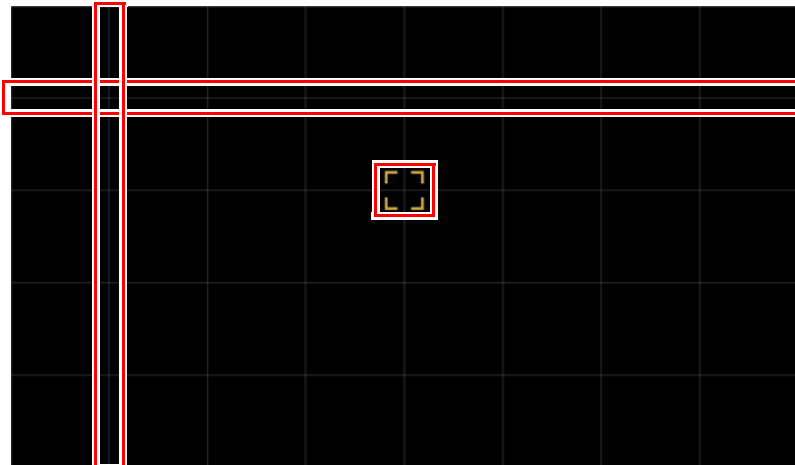

Press the **MENU** button to return to [Advanced registration].

Advanced Projection

3 Select [Red], [Green], or [Blue] as the color, and then press the OK button.



- Each time you select [Chart] and press the **OK** button, display switches between the chart and the source signal.
- Accessing the manual adjustment window during test pattern projection will show the test pattern instead of your supplied signal.

4 Use the [▲] / [▼] / [◀] / [▶] buttons to align the adjustment points.

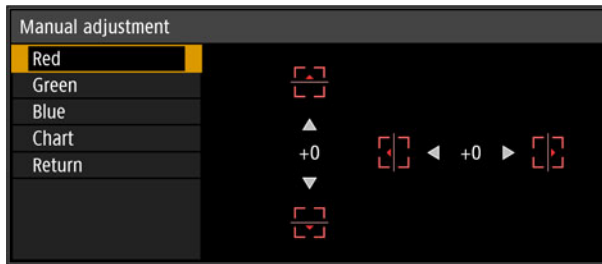

5 Press the OK button to return to the window for color selection mode.

6 Repeat this process to align the remaining colors and adjustment points.

■ Resetting Image Registration

Clears the values set in 5-point adjustment or manual adjustment.

1 In the [Install settings] menu, select [Professional settings] > [RGB alignment] > [Advanced registration] > [Adjust] > [Reset].

A confirmation message for resetting is displayed.

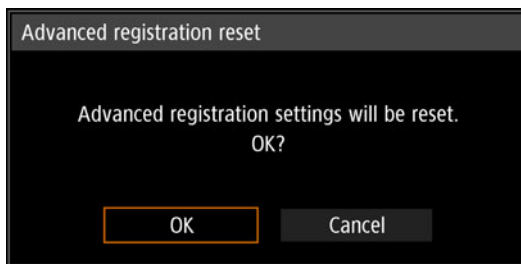

2 Select [OK] to reset the adjustment.

The following tasks are executed.

- Values set in 5-point adjustment are cleared.
- 5-point adjustment is deactivated.
- Values set in manual adjustment are cleared.

Adjusting Peripheral Focus

This feature enables focus adjustment around the edges of the screen.

- Use marginal focus adjustment for curved screens, such as domes.
- Use marginal focus adjustment to bring images on flat screens into focus if image edges remain warped after you adjust the overall focus.

 [Marginal focus] must be set to [On] in advance. (P112)

■ Bringing Image Edges into Focus

To adjust peripheral focus, press the **FOCUS** button on the remote control or the **LENS** button on the projector.

- 1 Press the **FOCUS** button on the remote control twice to display the marginal focus adjustment window.

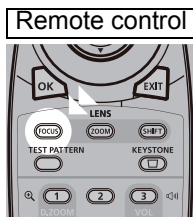

Press twice.

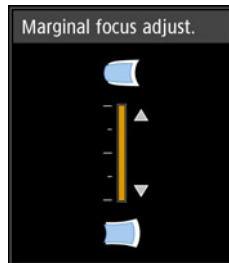

Pressing the **LENS** button on the projector repeatedly switches between windows for lens-related parameters.

Press the **LENS** button twice to display the marginal focus adjustment window.

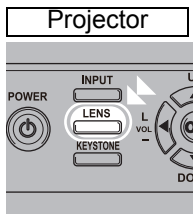

Press twice.

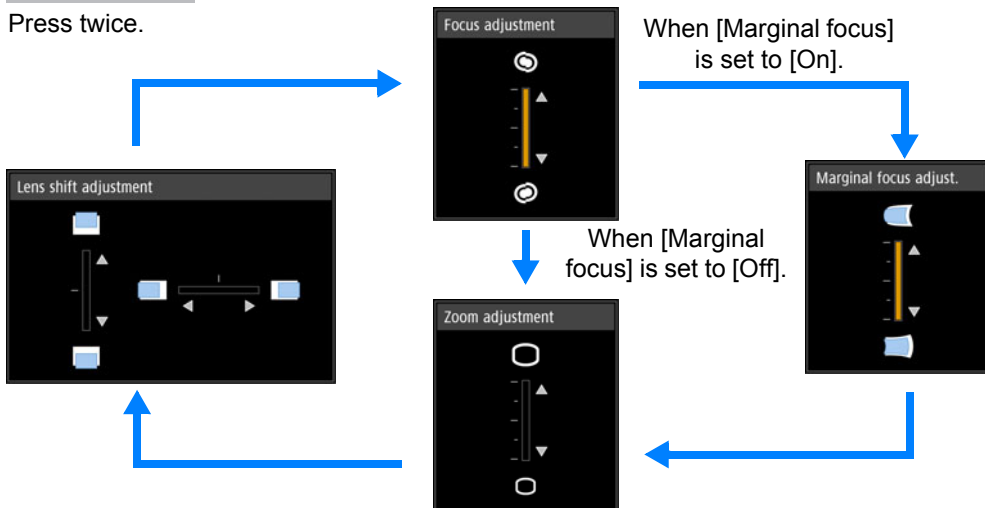

2 Press the pointer buttons to adjust the focus at image edges.

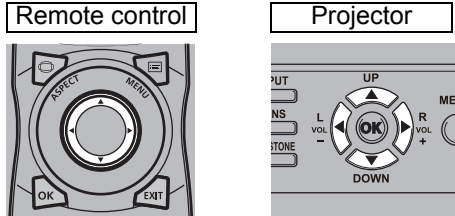

Press the [▲] / [▶] / [▼] / [◀] buttons to adjust peripheral focus.

3 Once image edges are in focus, press the OK or FOCUS button.

■ Resetting Adjustment

Clears the values set in marginal focus adjustment.

In the [Install settings] menu, select [Professional settings] > [Marginal focus] > [Reset] to reset the adjustment.

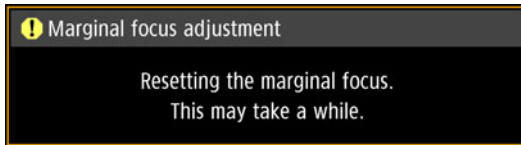

The following tasks are executed.

- Values set in marginal focus adjustment are cleared.
- [Marginal focus] is set to [Off].



Setting [Marginal focus] to [Off] will not reset the setting value for peripheral focus.

■ Using Trigger out

If you connect a screen or other external device to the projector's trigger terminal (P32) and configure [System settings], [Trigger out], [Link with power] (P133), operation of the device can be triggered by turning the projector on or off.

Other Information

Safety Instructions

Before Use

Basic Guide

Installation Procedure

Connection Procedure

Projection Procedure

Convenient Features

Advanced Guide

Using Menus

Menu Configuration

Menu Settings

Using the Projector on a Network

Advanced Projection

Other Information

Maintenance

Product Specifications

Troubleshooting

Cleaning the Projector

Clean the projector frequently to prevent dust from settling on the surface. A dirty lens may ruin the quality of the projected image.



Caution

Before cleaning the projector, always turn it off, unplug it after the cooling fan stops, and wait at least one hour. Otherwise, you may get burned because the main unit is very hot immediately after the projector is turned off.

Wipe the projector's main unit softly with a soft cloth. If the projector is heavily soiled, soak the cloth in water with a small amount of detergent in it, squeeze the cloth thoroughly, and then wipe the projector with it. After cleaning, wipe the projector with a dry cloth.

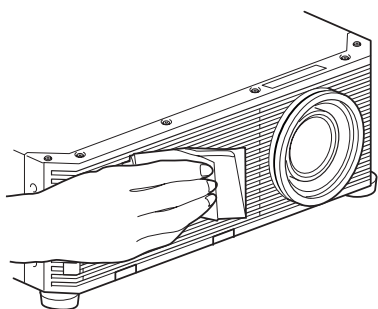

- Never use volatile cleaning liquid or benzene, as these may damage the finish of the projector.
- When using a chemical dust cloth, make sure to read the instructions thoroughly.
- When cleaning the projector's lens, use a commonly available air blower or lens cleaning paper. The lens surface is easily damaged, so do not use a hard cloth or tissues.

Replacing the Air Filter

The air filter protects the lens and mirror inside the projector from dust and dirt. Should the air filter become clogged with dust, the projector may be damaged since it will block the air flow into the projector and raise the internal temperature of the projector. (P208)

The following screen is displayed when turning on the projector if the air filter needs to be replaced. Replace the air filter if it is displayed.

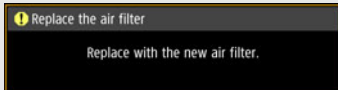

- Only the [◀], [▶], **OK**, **POWER**, **EXIT**, **FOCUS**, **ZOOM** and **SHIFT** buttons are available while this screen is displayed. (When you press the **POWER** button, the "Push POWER button again to turn off power." message appears.)
- When this screen has disappeared after being displayed for 10 seconds, all buttons become operable.

Follow the procedure below when replacing the air filter.

1 Turn off the projector power and remove the power plug.

- 2** Pull out the filter cover by gripping the two tabs at the bottom and lifting.

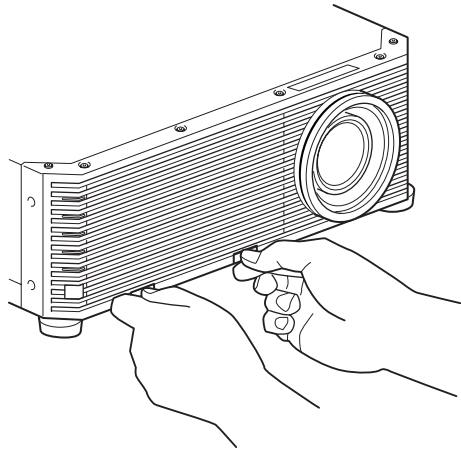

- 3** Open the filter cover and remove it.

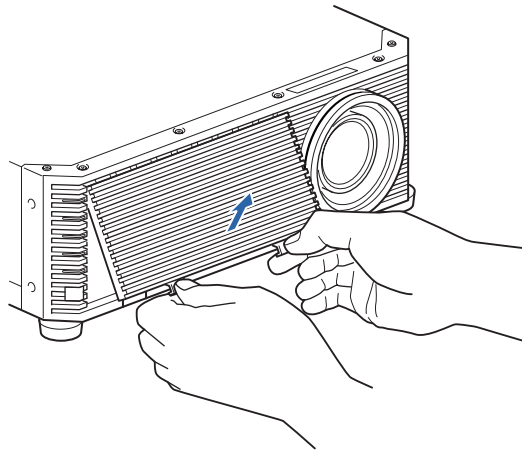

- 4** Grasp the air filter by the handles and remove it.

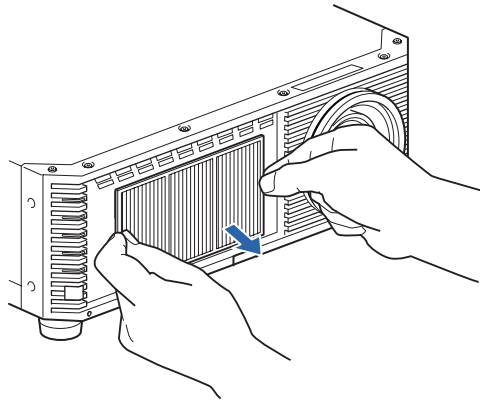

- 5** Holding the new air filter by the tab, insert the air filter in the projector.

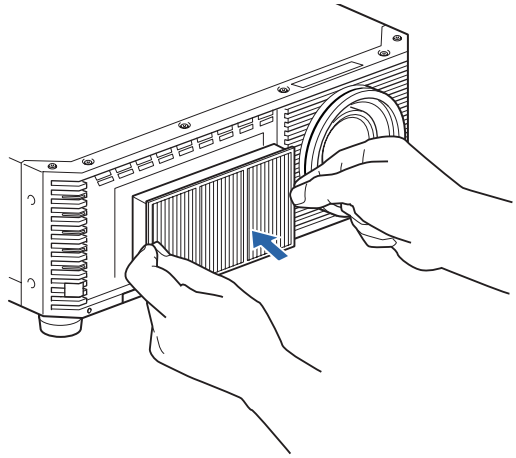

- 6** Align the filter cover tab with the groove and close the filter cover.

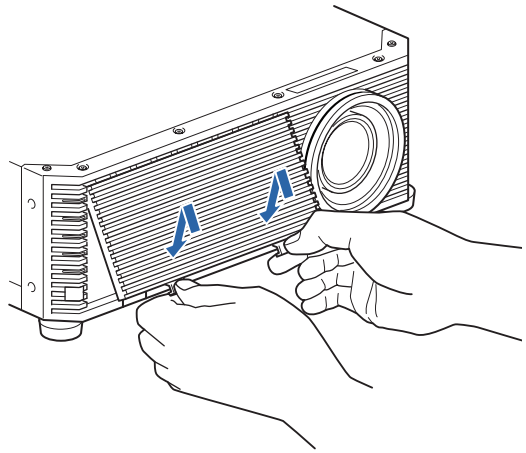

- Handle the air filter carefully. If damaged, the air filter will not work properly.
- To purchase a replacement air filter (part no: RS-FL04), contact the Canon Customer Support Center or visit the Canon website.

Displayed Test Patterns

To access the test pattern menu, from the [Install settings] menu, select [Test pattern] (P116) > [On], or press the **TEST PATTERN** button on the remote control. While the test pattern is displayed, you can use the [▲] / [▼] buttons to switch patterns. Also, if there is an option pattern available, you can use the [◀] / [▶] buttons to switch pattern.

The following test patterns can be displayed.

Use [▲] / [▼] to switch patterns

Use [◀] / [▶] to switch option patterns

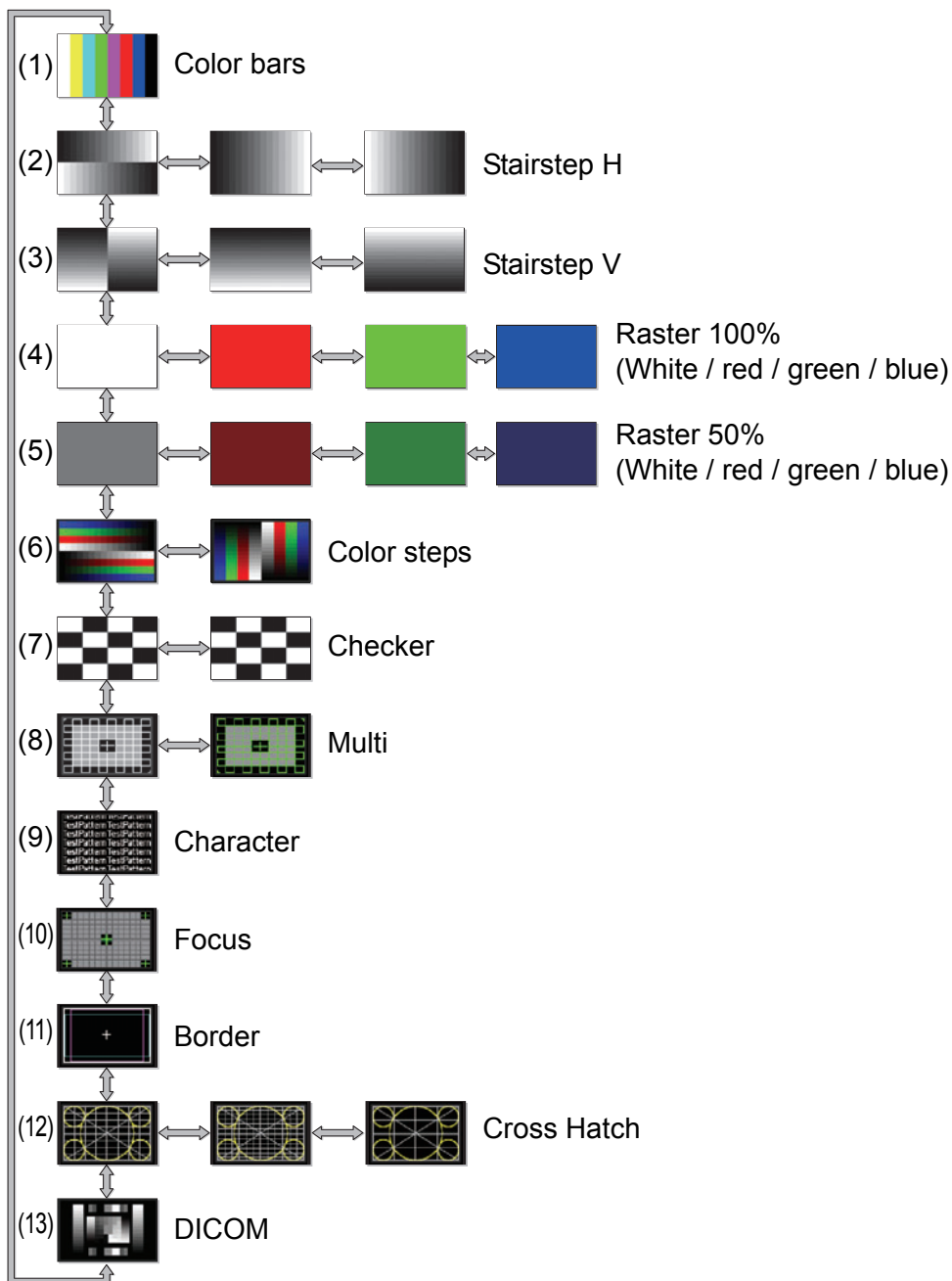

Supported Signal Types

The projector automatically projects input signals correctly from computers or AV equipment compatible with any of these signals.

HDMI (single)



FP : Front porch
 SW : Sync width
 BP : Back porch

| Signal resolution | Horizontal frequency [kHz] | Vertical frequency [Hz] | Dot clock [MHz] | HDMI multi input mode | Blanking information | |
|-------------------|----------------------------|-------------------------|--------------------|-----------------------|-----------------------|---------------------|
| | | | | | Horizontal FP, SW, BP | Vertical FP, SW, BP |
| 640x480 | 31.469 | 59.940 | 25.175 | Normal, Single | 16, 96, 48 | 10, 2, 33 |
| 720x480 | 31.469 | 59.940 | 27.000 | Normal, Single | 16, 62, 60 | 9, 6, 30 |
| 720x576 | 31.250 | 50.000 | 27.000 | Normal, Single | 12, 64, 68 | 5, 5, 39 |
| 800x600 | 37.879 | 60.317 | 40.000 | Normal, Single | 40, 128, 88 | 1, 4, 23 |
| 1280x720 | 18.000 | 24.000 | 59.400 | Normal, Single | 1760, 40, 220 | 5, 5, 20 |
| | 37.500 | 50.000 | 74.250 | Normal, Single | 440, 40, 220 | 5, 5, 20 |
| | 45.000 | 60.000 | 74.250 | Normal, Single | 110, 40, 220 | 5, 5, 20 |
| 1024x768 | 48.363 | 60.004 | 65.000 | Normal, Single | 24, 136, 160 | 3, 6, 29 |
| 1366x768 | 47.712 | 59.790 | 85.500 | Single | 70, 143, 213 | 3, 3, 24 |
| | 48.000 | 60.000 | 72.000 | | 14, 56, 64 | 1, 3, 28 |
| 1440x900 | 55.469 | 59.901 | 88.750 | Normal, Single | 48, 32, 80 | 3, 6, 17 |
| | 55.935 | 59.887 | 106.500 | Normal, Single | 80, 152, 232 | 3, 6, 25 |
| 1280x1024 | 63.981 | 60.020 | 108.000 | Normal, Single | 48, 112, 248 | 1, 3, 38 |
| 1920x1080(l) | 28.125 | 50.000 | 74.250 | Normal, Single | 528, 44, 148 | 4.5, 10, 30.5 |
| | 31.250 | 50.000 | 72.000 | | 32, 168, 184 | 45.5, 10, 114.5 |
| | 33.750 | 60.000 | 74.250 | Normal, Single | 88, 44, 148 | 4.5, 10, 30.5 |
| 1920x1080 | 27.000 | 24.000 | 74.250 | Normal, Single | 638, 44, 148 | 4, 5, 36 |
| | 56.250 | 50.000 | 148.500 | Normal, Single | 528, 44, 148 | 4, 5, 36 |
| | 67.500 | 60.000 | 148.500 | Normal, Single | 88, 44, 148 | 4, 5, 36 |
| 2048x1080 | 66.576 | 59.924 | 147.000 | Normal, Single | 48, 32, 80 | 3, 10, 18 |
| | 67.500 | 60.000 | 148.500 | Normal, Single | 44, 44, 64 | 4, 5, 36 |
| 2560x1080 | 26.400 | 24.000 | 99.000 | Normal, Single | 998, 44, 148 | 4, 5, 11 |
| | 56.250 | 50.000 | 185.625 | Normal, Single | 548, 44, 148 | 4, 5, 36 |
| | 66.636 | 59.978 | 181.250 | | 48, 32, 80 | 3, 10, 18 |
| | 66.000 | 60.000 | 198.000 | Normal, Single | 248, 44, 148 | 4, 5, 11 |
| 1920x1200 | 74.038 | 59.950 | 154.000 | Normal, Single | 48, 32, 80 | 3, 6, 26 |
| | 74.556 | 59.885 | 193.250 | Normal, Single | 136, 200, 336 | 3, 6, 36 |
| 2048x1200 | 74.582 | 59.905 | 205.250 | Normal, Single | 136, 216, 352 | 3, 10, 32 |
| | 74.100 | 60.000 | 157.684 | | 8, 32, 40 | 21, 8, 6 |
| 2560x1440 | 88.787 | 59.951 | 241.500 | Single | 48, 32, 80 | 3, 5, 33 |
| 2560x1600 | 98.713 | 59.972 | 268.500 | Normal, Single | 48, 32, 80 | 3, 6, 37 |
| 3840x2160 | 52.593 | 23.993 | 266.750 | | 216, 400, 616 | 3, 5, 24 |
| | 52.438 | 23.999 | 209.750 | | 48, 32, 80 | 3, 5, 17 |
| | 54.000 | 24.000 | 297.000 | Normal, Single | 1276, 88, 296 | 8, 10, 72 |
| | 56.250 | 25.000 | 297.000 | Normal, Single | 1056, 88, 296 | 8, 10, 72 |
| | 67.500 | 30.000 | 297.000 | Normal, Single | 176, 88, 296 | 8, 10, 72 |
| | 112.500 | 50.000 | 594.000 | Normal*3, Single*3 | 1056, 88, 296 | 8, 10, 72 |
| 4096x2160 | 135.000 | 60.000 | 594.000 | Normal*3, Single*3 | 176, 88, 296 | 8, 10, 72 |
| | 52.561 | 23.979 | 284.250 | | 224, 432, 656 | 3, 10, 19 |
| | 52.397 | 23.980 | 223.000 | | 48, 32, 80 | 3, 10, 12 |
| | 54.000 | 24.000 | 297.000 | Normal, Single | 1020, 88, 296 | 8, 10, 72 |
| | 56.250 | 25.000 | 297.000 | Normal, Single | 968, 88, 128 | 8, 10, 72 |
| | 67.500 | 30.000 | 297.000 | Normal, Single | 88, 88, 128 | 8, 10, 72 |
| | 112.500 | 50.000 | 594.000 | Normal*3, Single*3 | 968, 88, 128 | 8, 10, 72 |
| 135.000 | 60.000 | 594.000 | Normal*3, Single*3 | 88, 88, 128 | 8, 10, 72 | |

When you apply the settings in the HDMI multi input mode column, formats in corresponding rows are identified in the EDID. No information is provided in the EDID for fields that are blank, so the computer output format must be configured manually.

HDMI 1x2

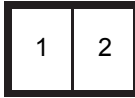

FP : Front porch
SW : Sync width
BP : Back porch

| Combined multi input resolution | Resolution at each input terminal | Horizontal frequency [kHz] | Vertical frequency [Hz] | Dot clock [MHz] | HDMI multi input mode | Blanking information | |
|---------------------------------|-----------------------------------|----------------------------|-------------------------|-----------------|-----------------------|-----------------------|---------------------|
| | | | | | | Horizontal FP, SW, BP | Vertical FP, SW, BP |
| 1280x480 | 640x480 | 31.469 | 59.940 | 25.175 | Normal, 1x2 | 16, 96, 48 | 10, 2, 33 |
| 1440x480 | 720x480 | 31.469 | 59.940 | 27.000 | Normal, 1x2 | 16, 62, 60 | 9, 6, 30 |
| 1440x576 | 720x576 | 31.250 | 50.000 | 27.000 | Normal, 1x2 | 12, 64, 68 | 5, 5, 39 |
| 2560x720 | 1280x720 | 37.500 | 50.000 | 74.250 | Normal, 1x2 | 440, 40, 220 | 5, 5, 20 |
| | | 45.000 | 60.000 | 74.250 | Normal, 1x2 | 110, 40, 220 | 5, 5, 20 |
| 3840x1080 | 1920x1080(l) | 28.125 | 50.000 | 74.250 | Normal, 1x2 | 528, 44, 148 | 4.5, 10, 30.5 |
| | | 33.750 | 60.000 | 74.250 | Normal, 1x2 | 88, 44, 148 | 4.5, 10, 30.5 |
| 3840x1080 | 1920x1080 | 67.500 | 60.000 | 148.500 | Normal, 1x2 | 88, 44, 148 | 4, 5, 36 |
| 2560x1600 | 1280x1600 | 98.611 | 59.910 | 142.000 | 1x2 | 48, 32, 80 | 3, 10, 33 |
| 3840x2160 | 1920x2160 | 52.404 | 23.983 | 109.000 | | 48, 32, 80 | 3, 10, 12 |
| | | 54.000 | 24.000 | 148.500 | 1x2*2 | 638, 44, 148 | 8, 10, 72 |
| | | 112.500 | 50.000 | 297.000 | 1x2 | 528, 44, 148 | 8, 10, 72 |
| | | 133.293 | 59.988 | 277.250 | | 48, 32, 80 | 3, 10, 49 |
| | | 135.000 | 60.000 | 297.000 | Normal, 1x2 | 88, 44, 148 | 8, 10, 72 |
| 4096x2160 | 2048x2160 | 133.320 | 60.000 | 266.640 | | 8, 32, 40 | 48, 8, 6 |
| | | 52.515 | 23.957 | 142.000 | | 112, 216, 328 | 3, 10, 19 |
| | | 52.423 | 23.992 | 115.750 | | 48, 32, 80 | 3, 10, 12 |
| | | 54.000 | 24.000 | 148.500 | 1x2 | 510, 44, 148 | 8, 10, 72 |
| | | 112.500 | 50.000 | 297.000 | 1x2 | 484, 44, 64 | 8, 10, 72 |
| | | 133.265 | 59.975 | 294.250 | | 48, 32, 80 | 3, 10, 49 |
| 3200x2400 | 1600x2400 | 133.320 | 60.000 | 283.704 | | 8, 32, 40 | 48, 8, 6 |
| | | 135.000 | 60.000 | 297.000 | Normal, 1x2 | 44, 44, 64 | 8, 10, 72 |
| | | 3200x2400 | 1600x2400 | 148.011 | 59.948 | 260.500 | 1x2*1 |
| 3840x2400 | 1920x2400 | 148.140 | 60.000 | 296.280 | | 8, 32, 40 | 55, 8, 6 |

When you apply the settings in the HDMI multi input mode column, formats in corresponding rows are identified in the EDID. No information is provided in the EDID for fields that are blank, so the computer output format must be configured manually.

DVI (single)



FP : Front porch
SW : Sync width
BP : Back porch

| Signal resolution | Horizontal frequency [kHz] | Vertical frequency [Hz] | Dot clock [MHz] | DVI multi input mode | Blanking information | |
|-------------------|----------------------------|-------------------------|-----------------|----------------------|-----------------------|---------------------|
| | | | | | Horizontal FP, SW, BP | Vertical FP, SW, BP |
| 640x480 | 31.469 | 59.940 | 25.175 | Normal, Single | 16, 96, 48 | 10, 2, 33 |
| 800x600 | 37.879 | 60.317 | 40.000 | Normal, Single | 40, 128, 88 | 1, 4, 23 |
| 1280x720 | 45.000 | 60.000 | 74.250 | Normal, Single | 110, 40, 220 | 5, 5, 20 |
| 1024x768 | 48.363 | 60.004 | 65.000 | Normal, Single | 24, 136, 160 | 3, 6, 29 |
| 1366x768 | 47.712 | 59.790 | 85.500 | Single | 70, 143, 213 | 3, 3, 24 |
| | 48.000 | 60.000 | 72.000 | | 14, 56, 64 | 1, 3, 28 |
| 1440x900 | 55.469 | 59.901 | 88.750 | Normal, Single | 48, 32, 80 | 3, 6, 17 |
| | 55.935 | 59.887 | 106.500 | Normal, Single | 80, 152, 232 | 3, 6, 25 |
| 1280x1024 | 63.981 | 60.020 | 108.000 | Normal, Single | 48, 112, 248 | 1, 3, 38 |
| 1920x1080 | 27.000 | 24.000 | 74.250 | Normal, Single | 638, 44, 148 | 4, 5, 36 |
| | 67.500 | 60.000 | 148.500 | Normal, Single | 88, 44, 148 | 4, 5, 36 |
| 2048x1080 | 66.576 | 59.924 | 147.000 | | 48, 32, 80 | 3, 10, 18 |
| | 67.500 | 60.000 | 148.500 | Normal, Single | 44, 44, 64 | 4, 5, 36 |

Product Specifications

| Signal resolution | Horizontal frequency [kHz] | Vertical frequency [Hz] | Dot clock [MHz] | DVI multi input mode | Blanking information | |
|-------------------|----------------------------|-------------------------|-----------------|----------------------|-----------------------|---------------------|
| | | | | | Horizontal FP, SW, BP | Vertical FP, SW, BP |
| 2560x1080 | 66.636 | 59.978 | 181.250 | | 48, 32, 80 | 3, 10, 18 |
| | 66.000 | 60.000 | 198.000 | Single | 248, 44, 148 | 4, 5, 11 |
| 1920x1200 | 74.038 | 59.950 | 154.000 | Normal, Single | 48, 32, 80 | 3, 6, 26 |
| | 74.556 | 59.885 | 193.250 | Normal, Single | 136, 200, 336 | 3, 6, 36 |
| 2048x1200 | 74.049 | 59.959 | 163.500 | Normal, Single | 48, 32, 80 | 3, 10, 22 |
| 2560x1440 | 88.787 | 59.951 | 241.500 | Single | 48, 32, 80 | 3, 5, 33 |
| 3840x2160 | 52.438 | 23.999 | 209.750 | Single | 48, 32, 80 | 3, 5, 17 |
| 4096x2160 | 52.397 | 23.980 | 223.000 | | 48, 32, 80 | 3, 10, 12 |

When you apply the settings in the DVI multi input mode column, formats in corresponding rows are identified in the EDID. No information is provided in the EDID for fields that are blank, so the computer output format must be configured manually.

DVI 1x2

| | |
|---|---|
| 1 | 3 |
|---|---|

FP : Front porch
SW : Sync width
BP : Back porch

| Combined multi input resolution | Resolution at each input terminal | Horizontal frequency [kHz] | Vertical frequency [Hz] | Dot clock [MHz] | DVI multi input mode | Blanking information | |
|---------------------------------|-----------------------------------|----------------------------|-------------------------|-----------------|----------------------------|-----------------------|---------------------|
| | | | | | | Horizontal FP, SW, BP | Vertical FP, SW, BP |
| 2560x1080 | 1280x1080 | 66.493 | 59.850 | 95.750 | 1x2 | 48, 32, 80 | 3, 10, 18 |
| 2560x1440 | 1280x1440 | 88.715 | 59.902 | 127.750 | 1x2 | 48, 32, 80 | 3, 10, 28 |
| 2560x1600 | 1280x1600 | 98.611 | 59.910 | 142.000 | Normal, 1x2 | 48, 32, 80 | 3, 10, 33 |
| 3840x2160 | 1920x2160 | 52.512 | 23.956 | 132.750 | | 104, 200, 304 | 3, 10, 19 |
| | | 52.404 | 23.983 | 109.000 | | 48, 32, 80 | 3, 10, 12 |
| | | 54.000 | 24.000 | 148.500 | Normal* ² , 1x2 | 638, 44, 148 | 8, 10, 72 |
| | | 67.500 | 30.000 | 148.500 | 1x2 | 88, 44, 148 | 8, 10, 72 |
| 4096x2160 | 2048x2160 | 52.515 | 23.957 | 142.000 | | 112, 216, 328 | 3, 10, 19 |
| | | 52.423 | 23.992 | 115.750 | | 48, 32, 80 | 3, 10, 12 |
| | | 54.000 | 24.000 | 148.500 | Normal* ² , 1x2 | 510, 44, 148 | 8, 10, 72 |
| | | 67.500 | 30.000 | 148.500 | 1x2 | 44, 44, 64 | 8, 10, 72 |

When you apply the settings in the DVI multi input mode column, formats in corresponding rows are identified in the EDID. No information is provided in the EDID for fields that are blank, so the computer output format must be configured manually.

DVI 2x2

| | |
|---|---|
| 1 | 3 |
| 2 | 4 |

FP : Front porch
SW : Sync width
BP : Back porch

| Combined multi input resolution | Resolution at each input terminal | Horizontal frequency [kHz] | Vertical frequency [Hz] | Dot clock [MHz] | DVI multi input mode | Blanking information | |
|---------------------------------|-----------------------------------|----------------------------|-------------------------|-----------------|--|-----------------------|---------------------|
| | | | | | | Horizontal FP, SW, BP | Vertical FP, SW, BP |
| 3840x2160 | 1920x1080 | 27.000 | 24.000 | 74.250 | Normal, 2x2 | 638, 44, 148 | 4, 5, 36 |
| | | 33.750 | 30.000 | 74.250 | Normal, 2x2 | 88, 44, 148 | 4, 5, 36 |
| | | 66.587 | 59.934 | 138.500 | Normal, 2x2 | 48, 32, 80 | 3, 5, 23 |
| | | 67.158 | 59.963 | 173.000 | Normal, 2x2 | 128, 200, 328 | 3, 5, 32 |
| | | 67.500 | 60.000 | 148.500 | Normal, 2x2 | 88, 44, 148 | 4, 5, 36 |
| 4096x2160 | 2048x1080 | 27.000 | 24.000 | 74.250 | 2x2* ² | 594, 44, 64 | 4, 5, 36 |
| | | 33.750 | 30.000 | 74.250 | 2x2* ² | 44, 44, 64 | 4, 5, 36 |
| | | 66.576 | 59.924 | 147.000 | 2x2 | 48, 32, 80 | 3, 10, 18 |
| | | 67.160 | 59.964 | 183.750 | | 128, 216, 344 | 3, 10, 27 |
| | | 67.500 | 60.000 | 148.500 | Normal, 2x2 | 44, 44, 64 | 4, 5, 36 |
| 4096x2304 | 2048x1152 | 70.992 | 59.909 | 156.750 | Normal* ¹ , 2x2* ¹ | 48, 32, 80 | 3, 5, 25 |
| | | 71.584 | 59.903 | 197.000 | Normal* ¹ , 2x2* ¹ | 136, 216, 352 | 3, 5, 35 |
| | | 72.000 | 60.000 | 162.000 | Normal* ¹ , 2x2* ¹ | 26, 80, 96 | 1, 3, 44 |

| Combined multi input resolution | Resolution at each input terminal | Horizontal frequency [kHz] | Vertical frequency [Hz] | Dot clock [MHz] | DVI multi input mode | Blanking information | |
|---------------------------------|-----------------------------------|----------------------------|-------------------------|-----------------|----------------------|-----------------------|---------------------|
| | | | | | | Horizontal FP, SW, BP | Vertical FP, SW, BP |
| 3200x2400 | 1600x1200 | 74.006 | 59.924 | 130.250 | 2x2*1 | 48, 32, 80 | 3, 4, 28 |
| | | 75.000 | 60.000 | 162.000 | 2x2*1 | 64, 192, 304 | 1, 3, 46 |
| 3840x2400 | 1920x1200 | 74.556 | 59.885 | 193.250 | Normal, 2x2*1 | 136, 200, 336 | 3, 6, 36 |
| | | 74.038 | 59.950 | 154.000 | Normal, 2x2*1 | 48, 32, 80 | 3, 6, 26 |
| 4096x2400 | 2048x1200 | 74.582 | 59.905 | 205.250 | | 136, 216, 352 | 3, 10, 32 |
| | | 74.049 | 59.959 | 163.500 | Normal, 2x2*1 | 48, 32, 80 | 3, 10, 22 |

When you apply the settings in the DVI multi input mode column, formats in corresponding rows are identified in the EDID. No information is provided in the EDID for fields that are blank, so the computer output format must be configured manually.

DVI 1x4



FP : Front porch
SW : Sync width
BP : Back porch

| Combined multi input resolution | Resolution at each input terminal | Horizontal frequency [kHz] | Vertical frequency [Hz] | Dot clock [MHz] | DVI multi input mode | Blanking information | |
|---------------------------------|-----------------------------------|----------------------------|-------------------------|-----------------|----------------------|-----------------------|---------------------|
| | | | | | | Horizontal FP, SW, BP | Vertical FP, SW, BP |
| 3840x2160 | 960x2160 | 134.036 | 59.918 | 178.000 | | 80, 104, 184 | 3, 10, 64 |
| | | 133.259 | 59.973 | 149.250 | 1x4*2 | 48, 32, 80 | 3, 10, 49 |
| | | 133.319 | 60.000 | 138.652 | | 8, 32, 40 | 48, 8, 6 |
| | | 135.000 | 60.000 | 148.500 | Normal, 1x4 | 44, 22, 74 | 8, 10, 72 |
| 4096x2160 | 1024x2160 | 134.055 | 59.926 | 188.750 | | 80, 112, 192 | 3, 10, 64 |
| | | 133.235 | 59.962 | 157.750 | 1x4*2 | 48, 32, 80 | 3, 10, 49 |
| | | 133.320 | 60.000 | 147.185 | | 8, 32, 40 | 48, 8, 6 |
| | | 135.000 | 60.000 | 148.500 | Normal, 1x4 | 22, 22, 32 | 8, 10, 72 |
| 4096x2304 | 1024x2304 | 142.103 | 59.959 | 168.250 | 1x4*1 | 48, 32, 80 | 3, 10, 53 |
| | | 143.111 | 59.979 | 201.500 | | 80, 112, 192 | 3, 10, 69 |
| | | 142.199 | 60.000 | 156.988 | 1x4*1 | 8, 32, 40 | 52, 8, 6 |
| 3840x2400 | 960x2400 | 147.991 | 59.940 | 165.750 | 1x4*1 | 48, 32, 80 | 3, 10, 56 |
| | | 149.096 | 59.974 | 198.000 | | 80, 104, 184 | 3, 10, 73 |
| | | 148.139 | 60.000 | 154.065 | Normal*1, 1x4*1 | 8, 32, 40 | 55, 8, 6 |
| 4096x2400 | 1024x2400 | 148.970 | 59.924 | 209.750 | | 80, 112, 192 | 3, 10, 73 |
| | | 148.015 | 59.949 | 175.250 | 1x4*1 | 48, 32, 80 | 3, 10, 56 |
| | | 148.139 | 60.000 | 163.546 | Normal*1, 1x4*1 | 8, 32, 40 | 55, 8, 6 |

When you apply the settings in the DVI multi input mode column, formats in corresponding rows are identified in the EDID. No information is provided in the EDID for fields that are blank, so the computer output format must be configured manually.

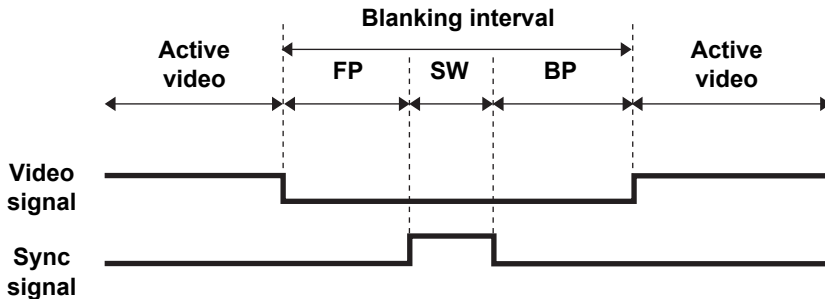

*1 Only when [Panel drive mode] is set to [4096x2400].

*2 Only when [Panel drive mode] is set to [4096x2160].

*3 Only YCbCr 4:2:0 is supported when [HDMI-1(2) EDID] is set to [9Gbps]. (RGB, YCbCr 4:4:4, and YCbCr 4:2:2 are not supported.)

Specifications

■ Projector

| | | | |
|---|------------------------------------|---|---|
| Model name | | 4K600STZ | |
| Display system | | Reflective liquid crystal (LCOS): 3 panels | |
| Optical system | | Color separation by dichroic mirror / polarizing beam splitter and color composition by prism | |
| Display device | Effective display area | 0.76" / 128:75 (approx. 17:10) | |
| | Effective pixels | 9,830,400 (4096 x 2400) | |
| | Other characteristics | Active matrix system | |
| Projection lens | Zoom | 1.3x (motorized) | |
| | Focus | Motorized | |
| | Lens shift | V: ±60% (motorized) H: ±10% (motorized) | |
| | Focal length | f = 17.2 – 22.3 mm | |
| | F number | F2.6 | |
| Light source | Type | Blue laser diode + yellow phosphor | |
| | Image size and projection distance | | Minimum: 101.6 cm (40"); maximum: 1,524 cm (600") Projection distance: 0.9 – 17.7 m (3 – 58') |
| Number of colors | | 16,770,000 colors | |
| Light output(*1)(*2) (Light source mode: Normal / Quiet 1 / Quiet 2) | | 6000 / 4560 / 2400lm | |
| Contrast ratio(*1)(*3)(*7) | | 4000:1 (Fully white:fully black, native) | |
| Ratio of brightness at periphery to center(*1) | | 80% | |
| Speaker | | 5W, monaural | |
| Supported input signals | | See "Supported Signal Types" (P198 – P201). | |
| Display resolution | Computer signal input | Maximum input resolution: 4096 x 2400 | |
| | Video signal input | Maximum input resolution: 4096 x 2160 | |
| Video signals | DVI input | DVI (single) | 640 x 480, 800 x 600, 1280 x 720, 1024 x 768, 1366 x 768, 1440 x 900, 1280 x 1024, 1920 x 1080, 2048 x 1080, 2560 x 1080, 1920 x 1200, 2048 x 1200, 2560 x 1440, 3840 x 2160(*4), 4096 x 2160(*4)(*5) |
| | | DVI (1 x 2) | 2560 x 1080, 2560 x 1440, 2560 x 1600, 3840 x 2160(*4), 4096 x 2160(*4) |
| | | DVI (2 x 2) | 3840 x 2160, 4096 x 2160, 4096 x 2304(*6), 3200 x 2400(*6), 3840 x 2400(*6), 4096 x 2400(*6) |
| | | DVI (1 x 4) | 3840 x 2160, 4096 x 2160, 4096 x 2304(*6), 3840 x 2400(*6), 4096 x 2400(*6) |

| Model name | | 4K600STZ | |
|------------------------------|--------------------|--|--|
| Video signals | HDMI input | HDMI (single) | 640 x 480, 720 x 480, 720 x 576, 800 x 600, 1280 x 720, 1024 x 768, 1366 x 768, 1440 x 900, 1280 x 1024, 1920 x 1080, 2048 x 1080, 2560 x 1080, 1920 x 1200, 2048 x 1200, 2560 x 1440, 2560 x 1600, 3840 x 2160, 4096 x 2160 |
| | | HDMI (1 x 2) | 1280 x 480, 1440 x 480, 1440 x 576, 2560 x 720, 3840 x 1080, 2560 x 1600, 3840 x 2160, 4096 x 2160, 3200 x 2400(*6), 3840 x 2400(*5)(*6) |
| Image signal input terminals | | DVI-D x 4 | Digital PC (29-pin DVI connector) |
| | | HDMI x 2 | Digital PC, Digital video |
| Other input/output terminals | Mini jack | | Audio input |
| | Mini jack | | Audio output |
| | Mini jack | | Wired remote control |
| | Mini jack | | Trigger output (12 V) |
| | RS-232C | | CONTROL (Dsub9) |
| | USB | | USB Type A |
| | RJ-45 | | Network connection (1000BASE-T/100BASE-TX/10BASE-T) |
| Noise | | 37 / 32 / 29 dB (Light source mode: Normal / Quiet 1 / Quiet 2) | |
| Operating temperature | | 0°C (32°F) – 45°C (113°F) | |
| Power supply | | AC 100 V – 240 V 50 / 60Hz | |
| Maximum power consumption | | 665 W | |
| Standby power consumption | LAN OFF | | 0.4 W |
| | LAN ON | | 0.8 W |
| Standard dimensions | | 559 mm (W) x 201 mm (H) x 624 mm (D) / 22.0 (W) x 7.9 (H) x 24.6 (D) | |
| Mass | | 26.0 kg / 57.3 lbs | |
| Accessories | | Remote control, remote control dry-cell batteries, power cord, lens cap, Important Information, User's Manual (CD-ROM) and Warranty Card | |
| Wireless connectivity | Standards | | IEEE802.11b/g/n |
| | Supported channels | | 1 CH - 11 CH |
| | Frequency band | | 2.4 GHz |

(*1) Compliance with ISO21118-2012

(*2) In [Presentation] image mode, with motion blur reduction set to [Off] and the light source mode set to [Normal].

(*3) In [4096x2400] panel drive mode, with motion blur reduction set to [Off] and the light source mode set to [Normal].

(*4) Only low frequencies (24-30 Hz) supported

(*5) EDID not supported

Product Specifications

(*6) When [Panel drive mode] is set to [4096x2400].

(*7) When [Close 3] is selected in [Iris].

- * 99.99% or more of the LCD panel pixels are effective. During projection, 0.01% or less of pixels may stay lit or unlit due to the characteristics of the LCD panel.
- * Using the projector continuously for an extended period of time may accelerate the deterioration of optical parts.
- * Product specifications and appearance are subject to change without notice.

■ Remote Control

| | |
|-----------------|--|
| Model number | RS-RC05 |
| Power supply | DC 3.0V, using two AA-size batteries |
| Operating range | Approx. 8 m / 26.2' ±25° horizontal and vertical (to infrared remote receiver) |
| Dimensions | 51 mm (W) x 28 mm (H) x 176 mm (D) / 2.0 (W) x 1.1 (H) x 6.9 (D) in |
| Weight | 100 g / 3.5 oz |

■ External View

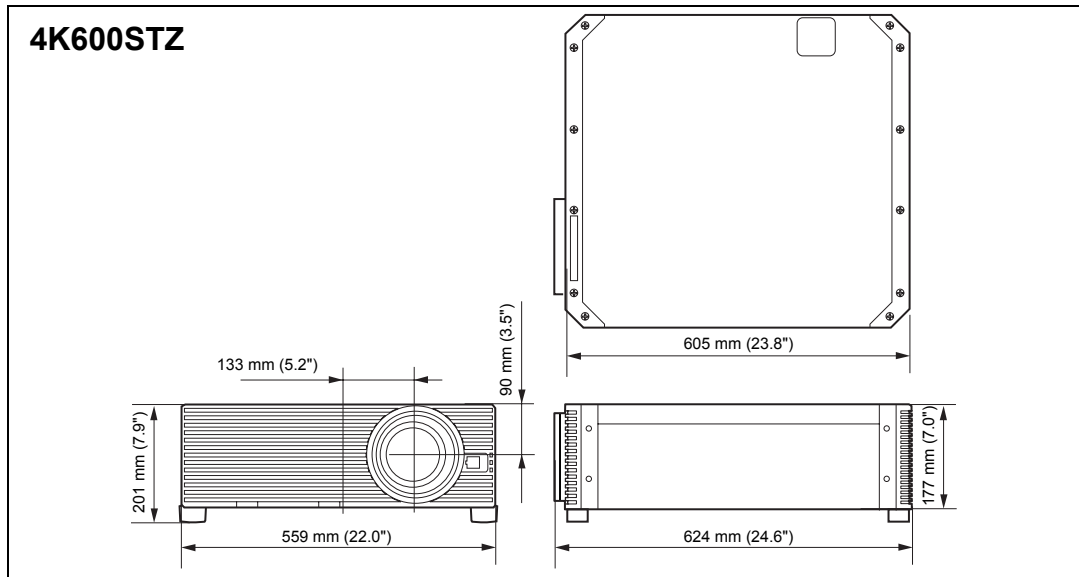

■ Service Port (CONTROL)

Pin assignment

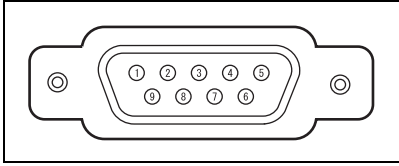

| Pin No. | Signal |
|---------|------------------|
| 1 | OPEN |
| 2 | RxD |
| 3 | TxD |
| 4 | OPEN |
| 5 | GND |
| 6 | OPEN |
| 7 | Internal pull-up |
| 8 | OPEN |
| 9 | OPEN |

Communication format

Communication mode : RS-232C, asynchronous, half-duplex communication

Communication speed : 19200bps

Character length : 8 bits

Stop bits : 1/2 bits

Parity : None

Flow control : None

Main user commands

| Commands | | ASCII representation | Binary representation |
|--------------------------|--------------------------|------------------------|---|
| Power supply | Power on | POWER=ON<CR> | 50h 4Fh 57h 45h 52h 3Dh 4Fh 4Eh 0Dh |
| | Power off | POWER=OFF<CR> | 50h 4Fh 57h 45h 52h 3Dh 4Fh 46h 46h 0Dh |
| Power status acquisition | | GET=POWER<CR> | 47h 45h 54h 3Dh 50h 4Fh 57h 45h 52h 0Dh |
| Input source | HDMI-1 | INPUT=HDMI1<CR> | 49h 4Eh 50h 55h 54h 3Dh 48h 44h 4Dh 49h 31h 0Dh |
| | HDMI-2 | INPUT=HDMI2<CR> | 49h 4Eh 50h 55h 54h 3Dh 48h 44h 4Dh 49h 32h 0Dh |
| | HDMI 1x2 | INPUT=HDMI1X2<CR> | 49h 4Eh 50h 55h 54h 3Dh 48h 44h 4Dh 49h 31h 58h 32h 0Dh |
| | DVI-1 | INPUT=D-RGB1<CR> | 49h 4Eh 50h 55h 54h 3Dh 44h 2Dh 52h 47h 42h 31h 0Dh |
| | DVI-2 | INPUT=D-RGB2<CR> | 49h 4Eh 50h 55h 54h 3Dh 44h 2Dh 52h 47h 42h 32h 0Dh |
| | DVI-3 | INPUT=D-RGB3<CR> | 49h 4Eh 50h 55h 54h 3Dh 44h 2Dh 52h 47h 42h 33h 0Dh |
| | DVI-4 | INPUT=D-RGB4<CR> | 49h 4Eh 50h 55h 54h 3Dh 44h 2Dh 52h 47h 42h 34h 0Dh |
| | DVI 1x2 | INPUT=D-RGB1X2<CR> | 49h 4Eh 50h 55h 54h 3Dh 44h 2Dh 52h 47h 42h 31h 58h 32h 0Dh |
| | DVI 2x2 | INPUT=D-RGB2X2<CR> | 49h 4Eh 50h 55h 54h 3Dh 44h 2Dh 52h 47h 42h 32h 58h 32h 0Dh |
| | DVI 1x4 | INPUT=D-RGB1X4<CR> | 49h 4Eh 50h 55h 54h 3Dh 44h 2Dh 52h 47h 42h 31h 58h 34h 0Dh |
| Input source acquisition | | GET=INPUT<CR> | 47h 45h 54h 3Dh 49h 4Eh 50h 55h 54h 0Dh |
| Image Mode | Standard | IMAGE=STANDARD<CR> | 49h 4Dh 41h 47h 45h 3Dh 53h 54h 41h 4Eh 44h 41h 52h 44h 0Dh |
| | Presentation | IMAGE=PRESENTATION<CR> | 49h 4Dh 41h 47h 45h 3Dh 50h 52h 45h 53h 45h 4Eh 54h 41h 54h 49h 4Fh 4Eh 0Dh |
| | Photo/sRGB | IMAGE=PHOTO_SRGB<CR> | 49h 4Dh 41h 47h 45h 3Dh 50h 48h 4Fh 54h 4Fh 5Fh 53h 52h 47h 42h 0Dh |
| | DICOM SIM | IMAGE=DCM_SIM<CR> | 49h 4Dh 41h 47h 45h 3Dh 44h 43h 4Dh 5Fh 53h 49h 4Dh 0Dh |
| | Dynamic | IMAGE=DYNAMIC<CR> | 49h 4Dh 41h 47h 45h 3Dh 44h 59h 4Eh 41h 4Dh 49h 43h 0Dh |
| | Video | IMAGE=VIDEO<CR> | 49h 4Dh 41h 47h 45h 3Dh 56h 49h 44h 45h 4Fh 0Dh |
| | User 1 | IMAGE=USER_1<CR> | 49h 4Dh 41h 47h 45h 3Dh 55h 53h 45h 52h 5Fh 31h 0Dh |
| | User 2 | IMAGE=USER_2<CR> | 49h 4Dh 41h 47h 45h 3Dh 55h 53h 45h 52h 5Fh 32h 0Dh |
| | User 3 | IMAGE=USER_3<CR> | 49h 4Dh 41h 47h 45h 3Dh 55h 53h 45h 52h 5Fh 33h 0Dh |
| Image mode acquisition | | GET=IMAGE<CR> | 47h 45h 54h 3Dh 49h 4Dh 41h 47h 45h 0Dh |
| Brightness | Brightness value setting | BRI=<value>CR | 42h 52h 49h 3Dh <numeric code> 0Dh |

| Commands | | ASCII representation | Binary representation |
|--------------------------|-------------------------|----------------------|---|
| Brightness acquisition | | GET=BRI<CR> | 47h 45h 54h 3Dh 42h 52h 49h 0Dh |
| Sharpness | Sharpness value setting | SHARP=<value><CR> | 53h 48h 41h 52h 50h 3Dh <numeric code> 0Dh |
| Sharpness acquisition | | GET=SHARP<CR> | 47h 45h 54h 3Dh 53h 48h 41h 52h 50h 0Dh |
| Contrast | Contrast value setting | CONT=<value><CR> | 43h 4Fh 4Eh 54h 3Dh <numeric code> 0Dh |
| Contrast acquisition | | GET=CONT<CR> | 47h 45h 54h 3Dh 43h 4Fh 4Eh 54h 0Dh |
| Aspect | Auto | ASPECT=AUTO<CR> | 41h 53h 50h 45h 43h 54h 3Dh 41h 55h 54h 4Fh 0Dh |
| | True size | ASPECT=TRUE<CR> | 41h 53h 50h 45h 43h 54h 3Dh 54h 52h 55h 45h 0Dh |
| Aspect value acquisition | | GET=ASPECT<CR> | 47h 45h 54h 3Dh 41h 53h 50h 45h 43h 54h 0Dh |
| Blank | Blank On | BLANK=ON<CR> | 42h 4Ch 41h 4Eh 4Bh 3Dh 4Fh 4Eh 0Dh |
| | Blank Off | BLANK=OFF<CR> | 42h 4Ch 41h 4Eh 4Bh 3Dh 4Fh 46h 46h 0Dh |
| Blank acquisition | | GET=BLANK<CR> | 47h 45h 54h 3Dh 42h 4Ch 41h 4Eh 4Bh 0Dh |

LED Indicator Details

When there is a problem with the projector, the LED indicator on the side of the projector illuminates or flashes continuously after the projector is turned off.

- Wait until the cooling fan stops and disconnect the power plug from the electrical outlet before dealing with the problem.

| LED indicator status | Meaning | Cause and countermeasure |
|--|-------------------------|--|
| WARNING and TEMP are lit. | Temperature abnormality | The temperature inside the projector is too high for some reason or the outside air temperature is higher than the operating range. If the problem is inside the projector, check whether the projector is installed and operating normally, unplug the projector from the power outlet to cool down the projector interior and then restart projection. If the air intake or exhaust vent is blocked, remove the obstacle. If the air filter is clogged, replace it. (P194) If the same warning occurs again, there may be a malfunction in the projector. Contact the Canon Customer Support Center. |
| WARNING and LIGHT are lit. | Faulty light source | The light source does not illuminate. Restart the projector and check projection. If the light source does not illuminate after this, the light source drive circuit may be damaged. Contact the Canon Customer Support Center. |
| WARNING (only) flashes 3 times repeatedly. | Filter error | The air filter is not installed correctly. Install the air filter correctly and restart the projector. Contact the Canon Customer Support Center if the same warning occurs again. |
| WARNING (only) flashes 4 times repeatedly. | Faulty cooling fan | There may be a malfunction in the cooling fan or another component. Unplug the projector from the electrical outlet, then plug it back into the outlet and turn on the projector again. Contact the Canon Customer Support Center if the same warning occurs again. |
| WARNING (only) flashes 5 times repeatedly. | Faulty power supply | Abnormal voltage is applied to some parts in the power supply or another failure may have occurred. Unplug the projector from the electrical outlet, then plug it back into the outlet and turn on the projector again. Contact the Canon Customer Support Center if the same warning occurs again. |

Symptoms and Solutions

■ You Cannot Turn on the Projector

| Cause | Countermeasure |
|---|---|
| The power cord is not connected correctly. | Check whether the power cord is connected correctly. (P51) |
| The power cord has just been connected. | Wait at least one second after plugging the projector in until you press the POWER button. You cannot turn the projector on immediately after plugging it in. (P52) |
| The safety device is activated because the air intake or the exhaust vent is blocked and the internal temperature of the projector has increased. | When the safety device is active, the [POWER] indicator does not turn on when you connect the power cord. You cannot disable this safety device. Remove any obstacle that is blocking the air intake or exhaust vent and contact the Canon Customer Support Center. |
| The air filter is not installed correctly. | Check whether the air filter is installed correctly. (P194) |
| Key lock is enabled. | Check that Key lock (P121) is not enabled for the projector or the remote control. |

■ You Cannot Project an Image from the Projector

| Cause | Countermeasure |
|--|--|
| A cable is not connected correctly. | Check whether the projector is connected to the computer or AV equipment correctly. (P44, P45) |
| 20 seconds have not elapsed since the projector was turned on. | When the projector is turned on, the opening window is displayed for approximately 20 seconds. To project an image immediately, press the OK button on the remote control or side control. (P29, P33) |
| No image is sent from the AV equipment. | Check whether an image is played on the connected video camcorder, DVD, etc. |
| Connection with the input terminal has not been performed correctly. | Check whether the AV equipment is connected to the projector input terminal correctly. (P32) |
| No input signal type has been selected for the connected AV equipment. | Check that the same input signal has been correctly selected for the connected AV equipment from the [INPUT] menu. (P55) |
| The input signal type is incorrect. | Check whether the selected input signal type is correct. (P55, P198) |

| Cause | Countermeasure |
|--|---|
| The BLANK function has been selected. | Press the BLANK button on the remote control. (P72) |
| No image is projected due to a problem with the computer. | Turn first the projector and then the computer off and then back on again. |
| The external monitor output is not set on the notebook computer correctly. | Turn on the external monitor output on the notebook computer. To turn on the external monitor output, press the [LCD] or [VGA] function key or a key with an icon for the external monitor, while holding down the [Fn] key on the keyboard of the notebook computer. With Windows 10 / Windows 8.1 / Windows 8 / Windows 7, you can turn on image output by holding down the Windows logo key and pressing the [P] key. (P54) The combination of keys used to perform this operation varies depending on the model of notebook computer. For more detailed information, refer to the manual that came with your computer. |
| The displayed image is not the same as that displayed on the computer. | Check whether the dual screen (multi-display) mode is selected on the computer. If dual screen mode is selected, change the computer display output to mirroring mode. The output setting method varies among computer manufacturers. For more detailed information, refer to the manual that came with your computer. |

■ There is no Sound

| Cause | Countermeasure |
|--|--|
| The audio cable is not connected correctly. | Check the audio cable connection. (P44, P45) |
| The MUTE function is enabled. | Press the MUTE button on the remote control. (P34) |
| The volume level is adjusted to the minimum. | Press the VOL button on the remote control or the VOL+ button on the side control to adjust the volume level. (P29, P34) |
| An audio cable with a built-in resistor is used. | Use an audio cable without a built-in resistor. |
| Audio in terminal select is [Off]. | Change the Audio In terminal to the appropriate setting. (P123) |

■ The Projected Image Is Blurred

| Cause | Countermeasure |
|---|---|
| The image is out of focus. | Adjust the focus. (P59) |
| The distance to the screen is too short. | Check whether the distance to the screen is appropriate. (P40) |
| The projector is not placed straight in front of the screen. | Check whether the projector is placed obliquely to the screen. A slight error in the projection angle can be corrected through the keystone adjustment function. (P65) |
| The projector has been moved to a place where the temperature varies a lot. | When the projector is moved from a location where the temperature is low to a location where the temperature is high, condensation may form on the lens. The condensation will evaporate after a period of time and the projector will be able to project a normal image. |
| The lens is stained. | Clean the lens. (P194) |
| Video is blurred. | Activate motion blur reduction. (P125) |
| Motion blur reduction is not available. | Motion blur reduction is not available in DICOM SIM image mode. |

■ You Cannot Project an Image Appropriately

| Cause | Countermeasure |
|--|---|
| The projected image is inverted in the vertical or horizontal direction. | The ceiling mounted / rear projection setting is incorrect. Check the [Image flip H/V] setting in the [Install settings] menu. (P107) |
| A computer cable is used in which some pins are not connected. | Use a computer cable in which all pins are connected. |

■ The Projector Power Turns Off

| Cause | Countermeasure |
|--|---|
| The air intake or exhaust vent is blocked. | Check whether the air intake or exhaust vent is blocked. If the air intake or exhaust vent is blocked, the temperature inside the projector will increase and the power is automatically turned off to protect the projector. (The [WARNING] indicator and [TEMP] indicator are lit.) Wait until the projector temperature drops, then make sure that the intake and exhaust vents (P28) are not blocked and turn on the projector. (P52) |

| Cause | Countermeasure |
|---|---|
| The air filter is dirty. | Check whether the air filter is clogged with dust. If the air filter is clogged, replace the air filter. (P194) |
| The operating environment is inappropriate. | Check whether the operating temperature is between 0°C (32°F) and 45°C (113°F). (P21) Projector settings must be adjusted when using the projector at altitudes of 2,300 m (7,545.8') or higher. In the [Install settings] menu, set [High altitude] under [Professional settings] to [On]. (P111) |

■ The Projector Cannot Join the Network

| Cause | Countermeasure |
|---|--|
| The LAN cable (shielded twisted pair) is not connected correctly. | Check whether the LAN cable (shielded twisted pair) is connected to the projector correctly. (P135) |
| The projector has not been on long enough (less than about 40 seconds). | Network connections are not available until about 40 seconds after startup. Wait at least 40 seconds, and then try to connect again. (P160) |
| The projector cannot join a wireless network. | Follow the instructions in “Network Setting” (P161 – P162), “Wireless LAN (Wi-Fi)” (P138), and “Detailed settings (wireless)” (P147 – P151) to set up the projector again. In PJ AP mode, try changing the wireless channel on the projector (P147 – P148). In infrastructure mode, try changing the wireless channel on the access point. If connection is still not possible, contact the Canon Customer Support Center. |

■ You Cannot Operate the Remote Control

| Cause | Countermeasure |
|--|---|
| Batteries are not installed properly or they have run out. | Check whether batteries are installed correctly. If batteries are installed correctly, replace them with new batteries. (P35) |
| You are operating the remote control from the outside of the remote control operating range. | Check whether you are operating the remote control within the remote control operating range of the main unit of the projector. (P36) |
| There is an obstacle between the projector and the remote control. | Remove the obstacle between the infrared remote receiver of the main unit of the projector and the remote control or point the remote control in an obstacle-free path. |

| Cause | Countermeasure |
|--|--|
| You are operating the remote control in an unsuitable operating environment. | Check whether the infrared remote receiver of the main unit of the projector is exposed to direct sunlight or strong light of lighting apparatus. (P36) |
| The channel setting of the remote control does not match the setting of the projector. | Check whether the channel setting of the remote control has been changed. You can check the [Remote control channel] setting in the [System settings] menu. (P122) |
| The key lock function is preventing operation of the remote control. | Check whether [Key lock] is enabled to disable the remote control operation. In the [System settings] menu, set [Key lock] to [Off]. (P121) |

Numerics

6-axis color adjust 103

A

Adjusting keystone distortion 65

Air filter 28, 194

Ambient light 101

AMX Device Discovery 153

ASPECT 64

Aspect 64

AUDIO IN terminal 32

AUDIO OUT terminal 32

Auto (Aspect) 64

B

BLANK 72

Brightness 99

C

Ceiling mounted 39, 107

Connecting to AV equipment 45

Contrast 99

Corner Adjustment 66

Crestron RoomView 153

D

Digital PC / DVI-D terminal 32

Direct power on 125

Display resolution (Preparing the
computer) 57

Dynamic gamma 102

E

Edge blending 4, 112, 183

Effect of ambient light 101

F

FREEZE 72

G

Gamma 99

H

HDMI terminal 32, 44, 45

I

IMAGE 69

Image adjustment 76, 97

Image mode (Image quality) 68

Information 76, 155

INPUT 55

Input signal select 55

Input terminal 32

K

Key lock 121

KEystone 65

Keystone 65

L

LAN port 32

Language 126

LED indicator 30, 208

Lens shift 42, 62

M

Memory color correction 103

MENU 76

Menu 76

Multi input 47, 108

N

Network password 141

Network settings 76, 135

Noise reduction 101

- O**
- OK..... 29, 33
 - Optical zoom..... 60
- P**
- Password 127, 128
 - PJLink 152, 177
 - POWER 52, 71
 - Projecting from Multiple Projectors at
Once (Edge Blending)..... 183
 - Projector on..... 118
- R**
- Rear projection..... 39, 107
 - Remote control..... 33, 34, 35, 122
 - Reset..... 67, 105, 134
- S**
- Screen color..... 115
 - Selecting a language 53, 126
 - Setting display status 76, 92
 - Sharpness..... 99
 - Side control 29
 - Signal type 198
 - Super white 93
 - System settings..... 76, 117
- T**
- Test pattern 197
 - True size (Aspect)..... 64
 - Turning on external monitor output ... 54
- U**
- USB port 32
- W**
- WARNING indicator 30, 208
 - Wi-Fi..... 5
 - Wired Networks..... 142
 - Wireless Networks 136, 142, 147

Option

- | | |
|---|--|
| <ul style="list-style-type: none">• Ceiling attachment Part No.: RS-CL15• Ceiling-mount arm Part No.: RS-CL17• Ceiling-mount pipe (400 - 600 mm / 15.7 - 23.6 in) Part No.: RS-CL08*• Ceiling-mount pipe (600 - 1000 mm / 23.6 - 39.4 in) Part No.: RS-CL09* | <ul style="list-style-type: none">• Air filter Part No.: RS-FL04• Remote control Part No.: RS-RC05• Remote control Part No.: RS-RC04 |
|---|--|

* Use the above materials to hang the projector from the ceiling.

* For ceiling mounting, both ceiling attachment (RS-CL15) and ceiling-mount arm (RS-CL17) are required.



CANON INC.

30-2, Shimomaruko 3-chome, Ohta-ku, Tokyo 146-8501, Japan

CANON U.S.A. INC.

One Canon Park, Melville, New York 11747, U.S.A.

For all inquires concerning this product, call toll free in the U.S. 1-800-OK-CANON

CANON EUROPE LTD.

3 The Square, Stockley Park, Uxbridge, Middlesex, UB11 1ET United Kingdom

CANON EUROPA N.V.

Bovenkerkerweg 59, 1185 XB Amstelveen, The Netherlands