



PRO|SCENE

WU1500

Premium image quality, exceptional
brightness and ultimate reliability

WUXGA 12,000 lumens

Motorised lens shift

Six lens options

Dual lamps with lamp relay and 24/7 operation

HDBaseT and 3G-SDI

360° operation with portrait mode



The ultimate installation projector

The Optoma ProScene WU1500 is a fully-featured installation projector, built for demanding professional applications where image quality, performance and reliability are paramount. Native WUXGA resolution, 12,000 lumens brightness and 5000:1 contrast deliver vivid, crystal-clear images, while dual lamps with lamp relay and 24/7 operation provide ultimate reliability, ensuring that this is a projector in which you can have complete confidence.

The dust-sealed, filter-free design prevents dust and dirt from affecting the optical system, ensuring optimal image quality with minimal maintenance requirements. Motorised lens shift, zoom and focus combined with 360° operation and interchangeable colour wheels provide total flexibility for simple, trouble-free installation. A choice of six premium-quality lenses, from wide focus through to extra-long zoom means that the WU1500 can be adapted to cover almost any projection distance.

An array of advanced connectivity options are provided as standard, including HDMI, DVI-D, 5 BNC, HDBaseT and SDI. Every aspect of the WU1500 has been carefully designed and built to suit the requirements of the professional installer – from the dependable lens mounting system, through to the backlit remote control keypad and operation panel. The Optoma ProScene WU1500 represents the ultimate in professional image projection.

WU1500 key features

- **Bright, detailed images** - 12,000 lumens, WUXGA resolution, 5000:1 contrast
- **Installation flexibility** - six motorised lens options, lens shift, 360° operation and portrait mode
- **Reliable** - 24/7 operation and dual lamps for added resilience
- **Ultimate connectivity** - HDBaseT, 3G-SDI, HDMI, DVI and 5 BNC
- **Powerful image processor** - Built-in edge blending and 3-axis colour matching system

Ultimate performance and reliability

The WU1500 features dual lamps, which can be operated together to yield maximum brightness. Alternatively, each lamp can be activated individually in Relay Mode. The latter effectively combines the lifespan of both lamps together, maximising the intervals between lamp changes.

Unparalleled installation flexibility

Motorised lens shift, zoom and focus combine with six lens options to provide the ultimate in flexible installation. The projector can be mounted at any angle along its horizontal axis, and can also operate in portrait mode, opening up a whole range of installation possibilities.

Comprehensive connectivity

Built to surpass the expectations of even the most demanding AV professional, the WU1500 features a range of built-in connectivity options. HDMI, DVI-D, 5 BNC, HDBaseT and 3G-SDI are all included as standard. Control can be delivered via network or serial port, while the WU1500 supports Crestron, Extron, AMX and PJ-Link protocols. The remote handset also supports wired connection, where line-of-sight operation is not possible.



Introduction

PRO|SCENE

For more than ten years, Optoma has been at the forefront of projector design and manufacture - one of the very few companies that focuses exclusively on projectors.

Today, the Optoma ProScene range represents the evolution of projection expertise, honed and refined by manufacturing and supporting millions of projectors the world over. This knowledge and skill has been distilled into the ProScene range of products and support services, which are designed specifically for demanding professional applications.

- | | | | |
|---------------------|---------------------|----------------------|-------------------|
| ✓ Higher education | ✓ Boardrooms | ✓ Digital signage | ✓ Post production |
| ✓ Lecture theatres | ✓ Broadcast studios | ✓ Stage shows | ✓ Theatre |
| ✓ Houses of worship | ✓ Large classrooms | ✓ Live events | ✓ Trade shows |
| ✓ Museums | ✓ Exhibitions | ✓ Projection Mapping | |
| ✓ Auditoriums | ✓ Conference rooms | ✓ Meeting rooms | |

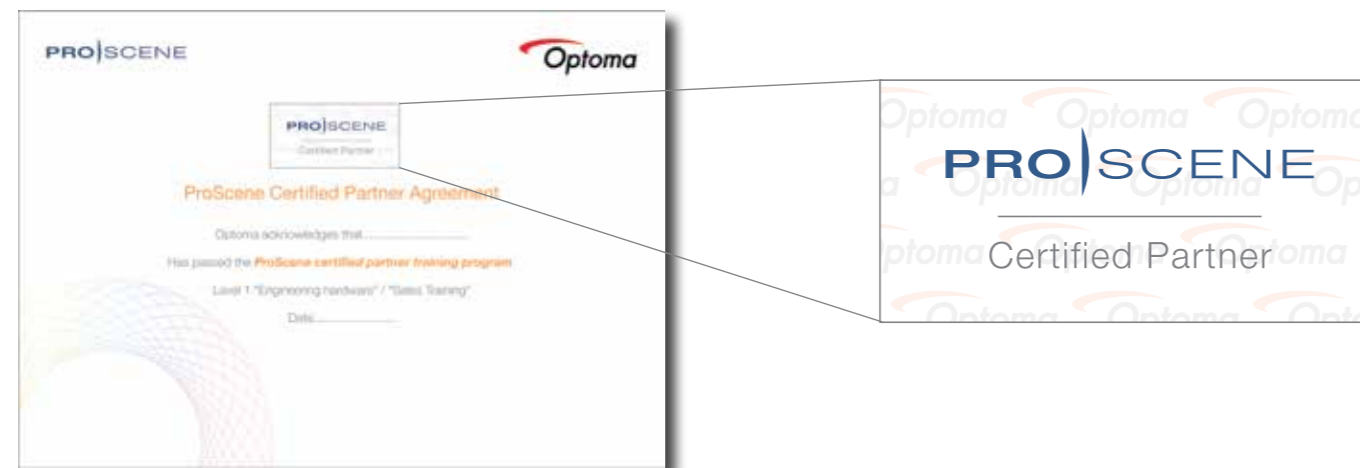

Key features

WU1500 features



Dual lamps with lamp relay

For challenging installations where the WU1500 is run for long periods, the Lamp Relay function can be used to automatically switch between projection lamps. Alternatively, both lamps can be used together to achieve maximum brightness.



Ultra-bright detailed images

The WU1500 has native WUXGA resolution (1920 x 1200 pixels), together with 12,000 lumens and 5000:1 contrast for vivid images.



Installation flexibility

Motorised lens shift, six lens options, 360° operation and portrait mode make the WU1500 truly adaptable to any installation scenario.



Extensive connectivity

HDMI, DVI, 5 BNC and 3G-SDI terminals enable connection to a wide range of high resolution digital and analogue sources.



Exemplary service

ProScene products benefit from a huge network of service centres across Europe, backed up by a range of extensive warranty and service packages.



HDBaseT

HDBaseT allows transmission of high-definition video, audio and control signals over a single CAT6 cable, vastly simplifying installation.



Image quality

Superb image quality is at the heart of every ProScene product. At every step, commencing with the incredibly reliable, high resolution WUXGA DLP® chip, where the image is initially created via the dual Philips UHP projection lamps, through to the precision optics which focus the image on the screen, accuracy and integrity of the image are paramount.

All Optoma ProScene projectors use DLP® technology for its image quality and unmatched reliability. The reflective nature of DLP® micro-mirror technology provides highly efficient, bright images with great contrast whilst maintaining precise colour accuracy and natural, real-world colour reproduction. For demanding professional applications, the proven reliability of DLP® technology makes it the obvious choice.

Better than Full HD resolution



When detail really matters, WUXGA resolution (1920 x 1200 pixels) offers 15% more image area than 1080p and 60% more than SXGA+. This enables unscaled Full HD video and extra detail. Time code information can be displayed on-screen at the same time, perfect for soundtrack recording and video editing editing where precise timing can be critical.

Lamps

The dual Philips 465W UHP lamps provide the highest possible luminance, the essential prerequisite of all high-performance projectors. These lamps stay brighter for longer, provide a long service life and a reduced loss of luminous flux throughout that life. In addition, the lamp drivers are specifically tuned for the lamps, ensuring optimum operating conditions and greater stability for any situation.



Lamp pulsing technology

Advanced lamp-pulsing technologies enable colour performance to be fine-tuned directly from the lamp. This unprecedented control helps to create vibrant, perfectly saturated colours across the whole light spectrum. The result is stunningly accurate, natural-looking images.

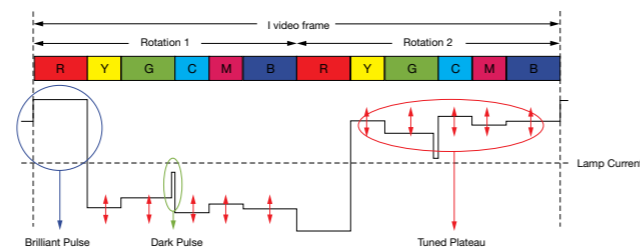

Reliability

The Optoma ProScene WU1500 is designed for continuous 24/7 operation. Only the most reliable, industry proven components are used to ensure superior reliability. This hard-earned “capability” has been meticulously developed over a decade of designing and supporting millions of projectors the world over. The dust-sealed, filter-free design prevents dust and dirt from affecting the system – ensuring optimal image quality with minimal maintenance. ProScene customers can therefore be confident that, as one of the most reliable projector brands in the industry today, Optoma has a reputation for service excellence that is well deserved.



Lamp switching

Dual lamps enable a level of reliability simply unavailable with a single-lamp projector. Both lamps can be used together to achieve maximum brightness, whilst still providing redundancy should one of them fail. Alternatively, a single lamp can be used in Relay Mode to deliver the full lifetime of each individual lamp, hence minimising service intervals.

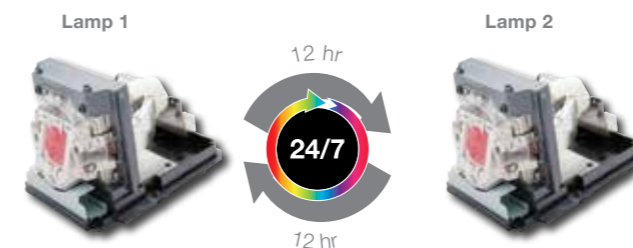

Precision optics

High quality glass optical elements maintain optimum sharpness and focus uniformity over the entire image. The ProScene insistence on uncompromising optical quality ensures extremely low colour flare and chromatic aberration resulting in crystal clear, high contrast images.

Select from a range of six premium-quality lenses, including short throw, wide zoom and long throw options. All have motorised shift, zoom and focus mechanisms, for easy and accurate adjustment after initial installation.



DLP® technology

DLP® technology from Texas Instruments® is widely recognised and acclaimed for its unmatched reliability and long lasting image performance. When combined with high brightness and native contrast ratios, it becomes the obvious choice for demanding applications. Independent testing has proven DLP® to be the most reliable of projector technologies. Whilst other technologies may show image quality decline after only a few thousand hours, DLP® technology can remain unchanged over hundreds of thousands of hours.



Total cost of ownership

For demanding applications, the total cost of ownership of a projector is not just in the purchase price, but also in expensive maintenance and service. ProScene projectors require very little maintenance, have no user serviceable parts inside and no filters that require periodic replacement. The result is low cost, predictable service cycles, enabling planned down time to be minimised.

We are so confident that the WU1500 image colour quality will remain as good as the day you bought it that Optoma will guarantee it for five years.





Flexibility

Installation flexibility

To meet the challenges of Pro AV installations, the WU1500 offers six lens options, each with motorised zoom and focus, to accurately deliver the required image size.

Motorised lens shift makes it easy to position the image exactly where you want it, while a choice of two different colour wheels allows the right balance of colour and brightness for any application.



All of the six optional lenses offer easy adjustment via the motorised lens shift, zoom and focus.

Motorised lens shift

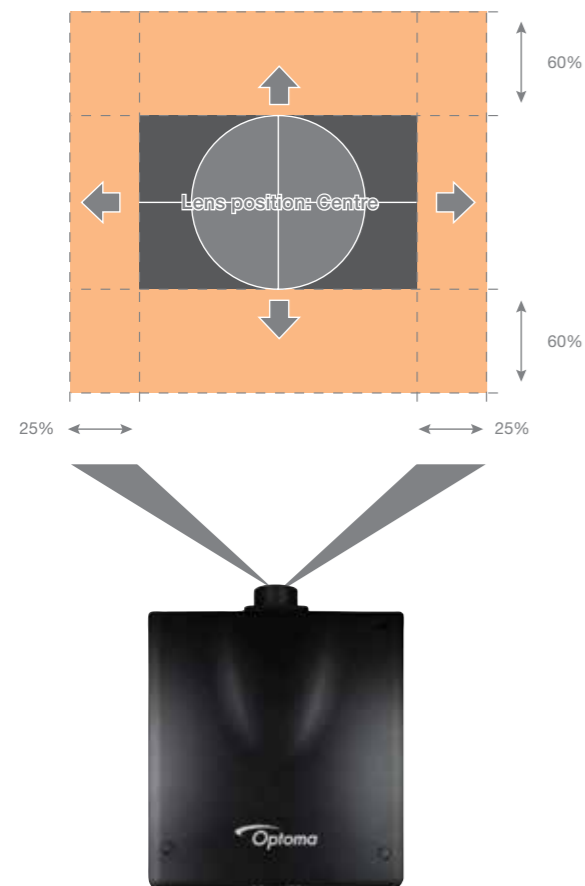

*Lens shift percentage is dependent on lens, see user manual for details

360° and portrait projection capability

Images can be projected over a full 360° range along the horizontal axis, including reproduction onto a ceiling or floor. The projector can also be placed in 'portrait mode' for applications such as digital signage and multi-projector displays.

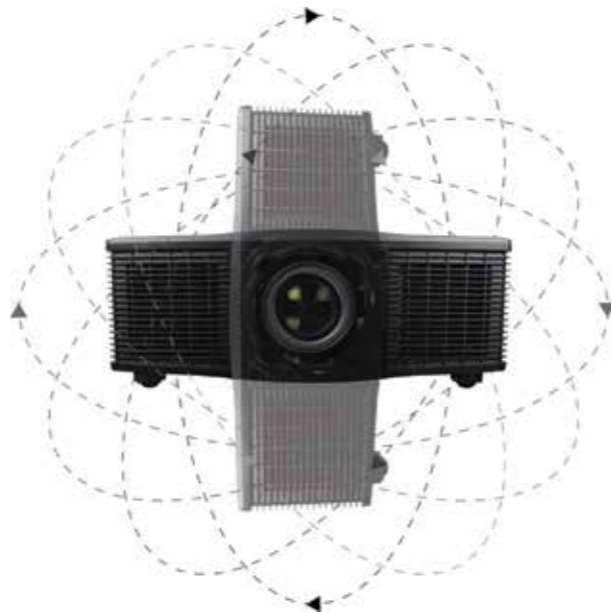

HDBaseT

HDBaseT enables transmission of uncompressed high definition video, audio, network and control signals over a single Category 6 twisted-pair cable. This streamlines installation and reduces labour, as well as allowing greater distances between the image source and the projector.



Flexibility

Mechanical shutter

For situations where only absolute darkness is good enough, the WU1500 has a mechanical shutter to provide total blackout. This makes it perfect for live events, such as scene changes during theatre performances.

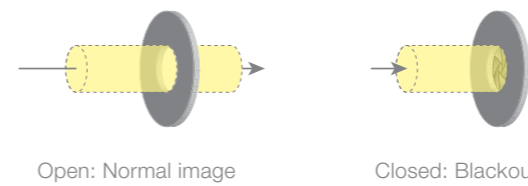

Edge-blending controls

No two projectors are completely identical. When performing edge-blend projects using multiple projectors, it can be difficult to achieve good results if the images do not match. The WU1500 incorporates the following features to ensure high quality and consistent results:

Colour matching

The WU1500 has a full 3-axis colour matching system, which, when combined with accurate measurements, can create seamless blends every time.



Brightness matching

To correctly match multiple units, the WU1500 has ten lamp power steps between 80% and 100% of full brightness. This helps to achieve balanced brightness levels between adjacent projectors.

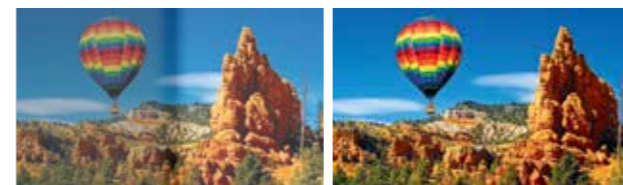

Without

With

Interchangeable colour wheels

Two colour wheel options ensure the performance characteristics of the WU1500 can be tailored to match the application. The standard colour wheel maximises brightness, whilst ensuring good colour reproduction. Alternatively, the 'rich colour' wheel trades some brightness for exceptional colour performance and accuracy. The colour wheels are interchangeable modules, and can be fitted or exchanged on-site, without removing the projector cover.



Projector security

The WU1500 features a Kensington lock slot, together with the ability to set a PIN code. This improves security and helps to deter projector theft.

Custom ID colours

The WU1500 is available in both black and white as standard. However, if your project calls for a higher level of customisation, the WU1500 is available in any colour from the RAL colour space.



Please contact your local sales representative for more information.



Control



System integration and control

Multiple WU1500 projectors can be monitored over the LAN and can also send an email alert via Crestron RoomView in the event of an error or a lamp failure. Projector status can be monitored via a web browser, while Extron IP Link, AMX Device Discovery and PJ-Link protocols offer remote management of most functions across a network, keeping you in control wherever you are.

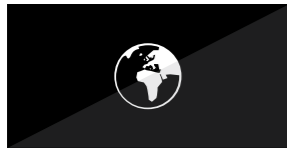

Global monitoring of all AV devices

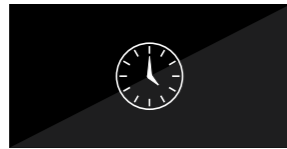

Track projector light source usage



Email alerts and instant notifications - helpdesk requests, service reminders, device failure or theft

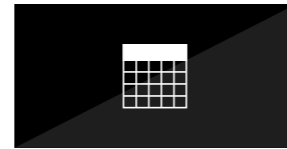

Event scheduling

Ultimate control

Cut up to 30% from your energy bills using 24-hour automated power scheduling to ensure that projectors power off when not in use.



Download Crestron RoomView® Express for free at www.crestron.com/getroomview

Help alert

Real-time interactive helpdesk requests are sorted to come to the top. The helpdesk then has the ability to respond with an automatic message or instant message the room with exact procedures.

Display power

Check on/off status of display power and system power. View a bar graph to monitor the percentage of available projector light source usage and set an alert to notify the service or facilities department when maintenance is needed.

Display usage

A visual indication of light source or service interval status.

Schedule event

RoomView Express makes scheduling of recurring or one time events easy. Setting RoomView to automatically power down at midnight throughout the week can save valuable light source life and ensure security inside the facility.

Selected view by rooms, attributes or contacts

RoomView Express gives you the ability to simultaneously view more than 250 rooms from a single screen. Customise RoomView to view by room name, locations and group.

Event log

Automatically generates log files, reports and charts to analyze ROI and budget allocation. Track device usage, call statistics and user history.

Lenses

Lens options



Optoma model name	A18	A19	A20	A21	A22	A23
Lens name	Short zoom	Wide zoom	Semi-Wide zoom	Standard	Long zoom	Extra-Long zoom
Throw ratio	0.84 ~ 1.02	1.02 ~ 1.36	1.2 ~ 1.5	1.5 ~ 2.0	2.0 ~ 4.0	4.0 ~ 7.2
Zoom ratio	1.2x	1.33x	1.25x	1.33x	2.0x	1.8x
F number	2.0	2.0	2.2	2.0	2.2	2.2
Focal length (f) mm	21.5 ~ 28.7mm	21.5 ~ 28.7mm	25.5 ~ 31.8mm	31.8 ~ 42.1mm	42.4 ~ 84.5mm	84.1 ~ 149.8mm
Zoom and Focus adjustment	Motorised zoom, motorised focus					
Throw distance (m)	0.9m ~ 11.0m	1.1m ~ 14.7m	1.3m ~ 16.2m	1.6m ~ 21.5m	2.2m ~ 43.1m	4.3m ~ 77.6m
Projected image size	50" - 500" diagonal (108 x 67cm to 1077 x 673cm)					
Motorised lens shift	Limited range		Vertical: +/-60% offset, Horizontal: +/- 25% offset			
Brightness ratio	85%	90%	95%	100%	90%	90%

Throw distance chart

Diagonal image size (Inch)	Image width (m)	Image height (m)	A18 - Short Zoom		A19 - Wide Zoom		A20 - Semi-wide Zoom		A21 - Standard		A22 - Long Zoom		A23 - Extra-Long Zoom	
			Min (m)	Max (m)	Min (m)	Max (m)	Min (m)	Max (m)	Min (m)	Max (m)	Min (m)	Max (m)		
50	1.08	0.67	0.90	1.10	1.10	1.46	1.29	1.62	1.62	2.15	2.15	4.31	4.31	7.75
80	1.72	1.08	1.45	1.76	1.76	2.34	2.07	2.58	2.58	3.45	3.45	6.89	6.89	12.41
100	2.15	1.35	1.81	2.20	2.20	2.93	2.58	3.23	3.23	4.31	4.31	8.62	8.62	15.51
120	2.58	1.62	2.17	2.64	2.64	3.52	3.10	3.88	3.88	5.17	5.17	10.34	10.34	18.61
150	3.23	2.02	2.71	3.30	3.30	4.39	3.88	4.85	4.85	6.46	6.46	12.92	12.92	23.26
200	4.31	2.69	3.62	4.39	4.39	5.86	5.17	6.46	6.46	8.62	8.62	17.23	17.23	31.02
250	5.38	3.37	4.52	5.49	5.49	7.32	6.46	8.08	8.08	10.77	10.77	21.54	21.54	38.77
300	6.46	4.04	5.43	6.59	6.59	8.79	7.75	9.69	9.69	12.92	12.92	25.85	25.85	46.52
400	8.62	5.38	7.24	8.79	8.79	11.72	10.34	12.92	12.92	17.23	17.23	34.46	34.46	62.03
500	10.77	6.73	9.05	10.98	10.98	14.65	12.92	16.15	16.15	21.54	21.54	43.08	43.08	77.54

For guidance only

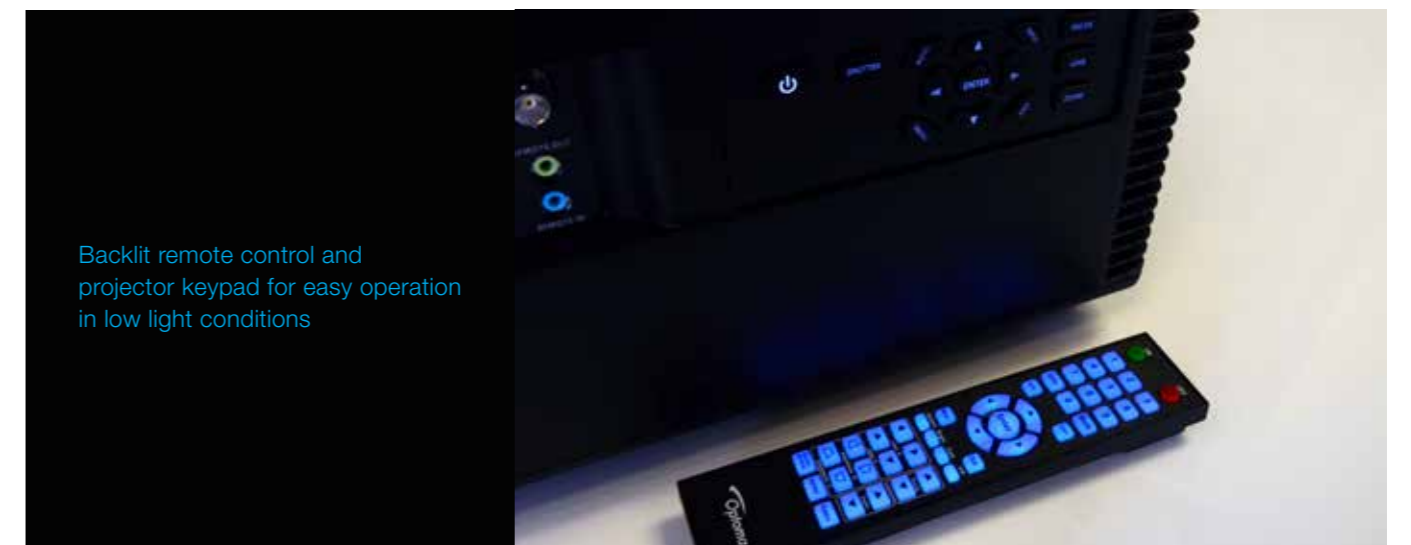

Backlit remote control and projector keypad for easy operation in low light conditions



Service, support and warranties

ProScene Certified Partners

Optoma understands that for ProScene customers, their high specification projector must be of exceptional quality and that the level of support and expertise provided by AV installers and integrators must also be of the highest calibre. To maintain this standard throughout, we have selected only the very best from within the AV industry to become ProScene Certified Partners.

These rigorously selected partners understand your specific requirements and perhaps as importantly, they have direct access to the specially-trained Optoma support and service teams. Our dedicated experts are available from the initial design and planning phase of a project, right through to the installation stages and beyond. Through our partners, you will have access to one of the most comprehensive projector service networks in Europe.

Choosing your ProScene projector is just the start. Total support and service excellence are at the core of the ProScene philosophy, ensuring industry-leading dedication to delivering the highest standard of expertise from Optoma and from our Certified Partners.

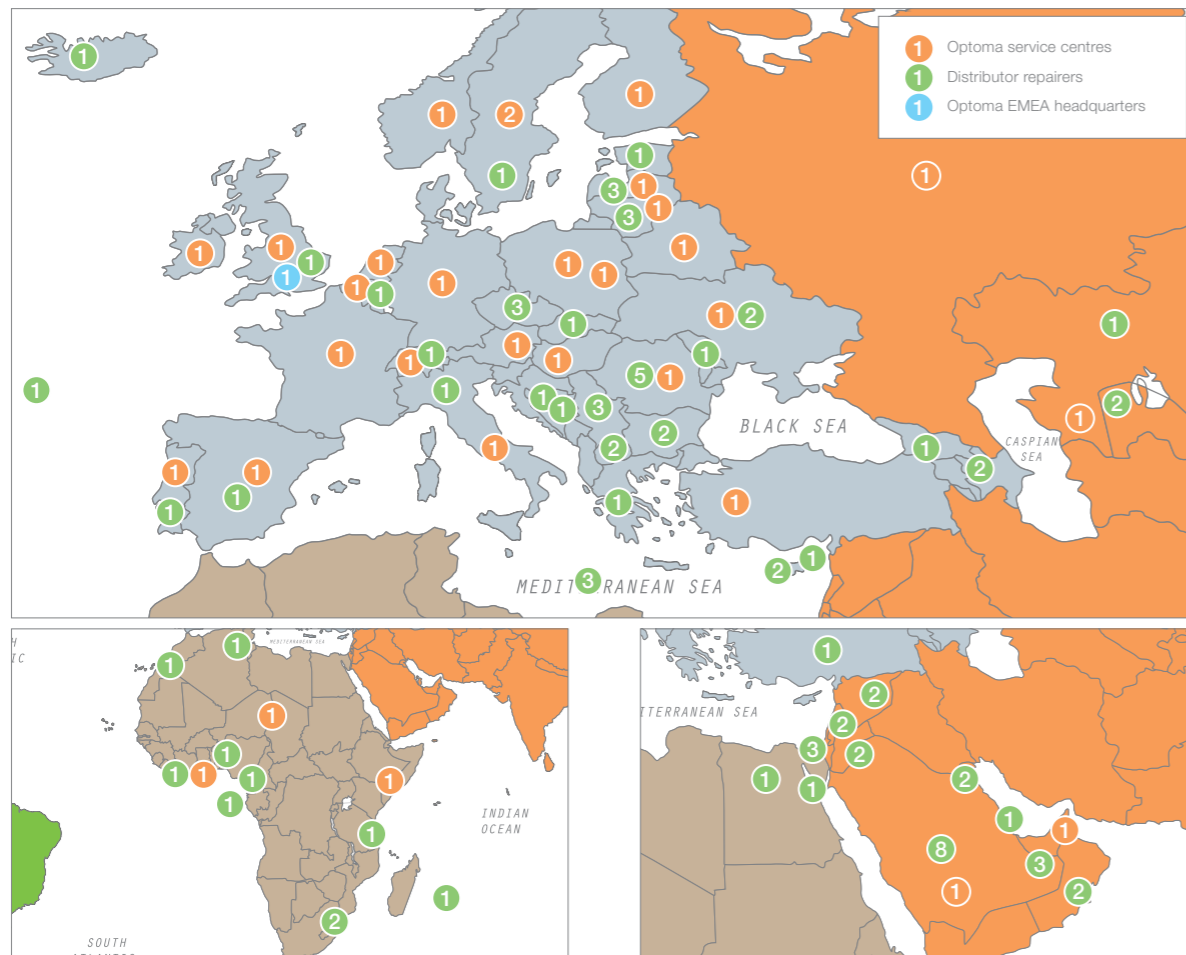

Standard and optional warranties

In addition to our Standard Warranty, we offer a range of optional warranty and preventative maintenance service packages – see website for details.



Training

Our training courses are developed and tutored by the ProScene technical services team. This ensures Certified Partners have access to expert knowledge of ProScene products and tutors who are familiar with the real-world scenarios faced by our partners.



Green



We know that improving our products is the best way to reduce our impact on the environment. That's why at Optoma, we design our products to have a long usable life, use fewer materials, ship with the minimum packaging and be free of all possible toxic substances. Naturally, energy efficiency and being recyclable are built in at the design stage. With each new product, we strive towards minimising our environmental impact. For full details of Optoma Project Green please visit our website.

Eco-friendly and highly efficient

Cut up to 30% from your energy bills using 24-hour automated power scheduling to ensure that projectors power off when not in use.



Direct power on

The projector will start up instantly when power is applied to the unit. This eliminates the need to manually turn on the projector via the remote control or the keypad, ideal for use in rooms with a "master" power switch.



Auto power off

If after a pre-determined time the projector does not receive a signal, it will shut down automatically, conserving power and extending the life of the light source.



Eco standby mode

Reduces energy consumption to less than 0.5W when the projector is not in use.



Dimensions



Labelling

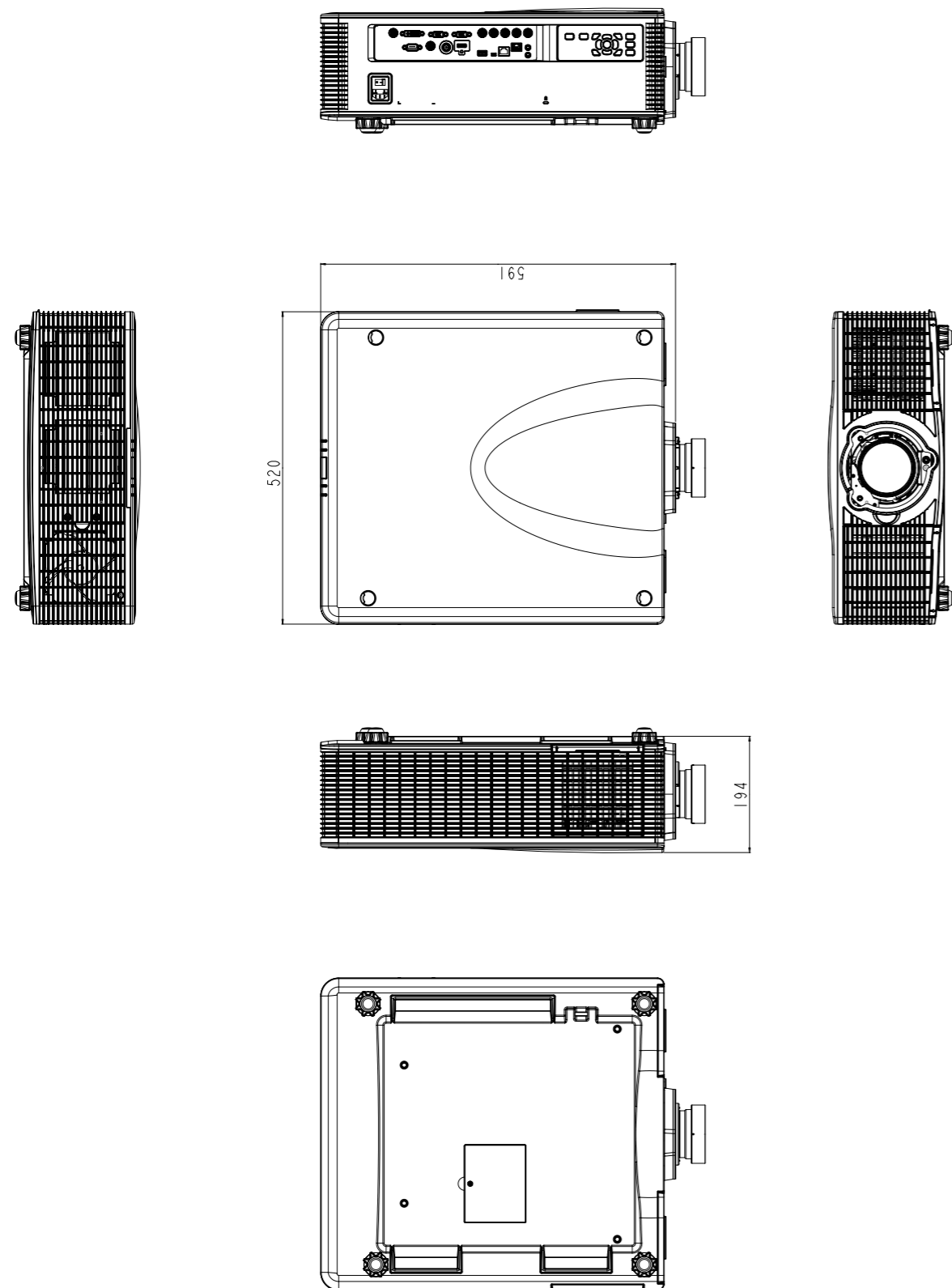

Input / output connections

1. 3D sync
2. DVI-D
3. VGA / YPbPr
4. VGA Out
5. Analogue RGB
6. RS-232
7. Composite video
8. 3G-SDI
9. HDMI V1.4b
10. USB wireless
11. Service port
12. RJ-45
13. HDBaseT
14. Wired remote in
15. Wired remote out



Keypad

1. Power
2. Mechanical shutter
3. Auto
4. Direction keys
5. Input select
6. Menu
7. Exit
8. Motorised focus
9. Motorised lens shift
10. Motorised zoom





Technical specifications

Projector		
Display technology		1 x 0.96" DLP® chip, DarkChip3™
Native resolution		WUXGA 1920 x 1200 pixels
Brightness¹		12,000 centre lumens (11,000 ANSI)
Contrast		5000:1 (1200:1 full on / full off, 250:1 ANSI)
Aspect ratio		16:10 native, 16:9 and 4:3 compatible
Optics		
Light source		2 x 465W UHP
Light source expected lifetime² (max hrs)		1500 hours (bright mode), 2000 hours (eco mode)
Projection lenses		A18 - Short zoom, 0.84 - 1.02 (1.2x zoom), F/2.0
(no lens supplied as standard)		A19 - Extra-wide zoom, 1.02 - 1.36 (1.3x zoom), F/2.0
		A20 - Wide zoom, 1.20 - 1.50 (1.25x zoom), F/2.2
		A21 - Standard zoom, 1.50 - 2.0 (1.3X zoom), F/2.0
		A22 - Long zoom, 2.0 - 4.0 (2.0x zoom), F/2.2
		A23 - Extra-long zoom 4.0 - 7.2 (1.8x zoom), F/2.2
Zoom / Focus type		Motorised zoom, motorised focus
Projection distance		0.9m - 77.6m (dependent upon lens)
Image size		50" - 500" (127cm - 1270cm) diagonal, 16:10
Lens shift		Vertical +/- 60°, Horizontal +/- 25°
Keystone correction		Vertical +/- 20°, Horizontal +/- 20°
Uniformity		90%
Shutter		Mechanical
Colour wheel		Bright wheel: 6 segment RGBCYW (standard)
Connectivity		
Inputs		HDMI - V1.4b (with locking screw)
		DVI-D - 29-pin DVI (digital signal only)
		VGA - 15-pin D-sub
		Analogue RGB / Component - 5x BNC (R/G/B/H/V)
		HD-BaseT - RJ-45
		3G-SDI - BNC
		Composite - BNC
		USB Wireless - USB Type A
Output		VGA Out - 15-pin D-sub
Control and communication		Network Port - RJ-45 (100BaseT)
		Serial (RS-232) - 9-pin D-sub
		Wired Remote In - 3.5mm mini-jack
		Wired Remote Out - 3.5mm mini-jack
		Service Port - Mini USB
		3D Sync - BNC
General		
Noise level³		39dB (bright mode) / 36dB (eco mode)
Weight		23.8kg (without lens)
Dimensions (W x D x H)		520 x 591 x 194mm (without protrusions)
Power requirements		100 - 240V AC @ 50 - 60Hz
Power consumption		1080W bright mode, 870W eco mode, <0.5W standby
Heat dissipation		3683 BTU/hr
Operating conditions		0°C - 40°C, 85% max humidity, 3000m max altitude
Portrait mode		Yes
360° operation		Yes
OSD languages		10 Languages: English / German / French / Italian / Spanish / Russian / Japanese / Korean / Simp Chinese / Trad Chinese
Built-in audio		No
Security		Kensington Lock port, PIN code
Warranty		3 years
Supplied accessories		
Cables		AC mains power cable VGA cable
Components		Remote control handset 'AAA' batteries
Documentation		User manual (on CD)



Accessories

Short ceiling mount

The universal ceiling mount is a rigid and strong ceiling mount suitable for suspending the WU1500 projector from the ceiling.

- Maximum load 70 Kg
- Standard equipped with the patented ball-joint.
- Maximum adjustment angle 20 degrees
- Fixed length of 165 mm
- Suitable for WU1500 projector base plate

Long ceiling mount

The universal ceiling mount is a rigid and strong ceiling mount suitable for suspending the WU1500 projector from the ceiling.

- Maximum load 70 Kg
- Standard equipped with the patented ball-joint
- Maximum adjustment angle 20 degrees
- Adjustable between 700 - 940 mm
- Suitable for WU1500 projector base plate

Projector base plate

Steel base plate made specifically to fit the WU1500 projector. Use in conjunction with either the short or long ceiling mount.

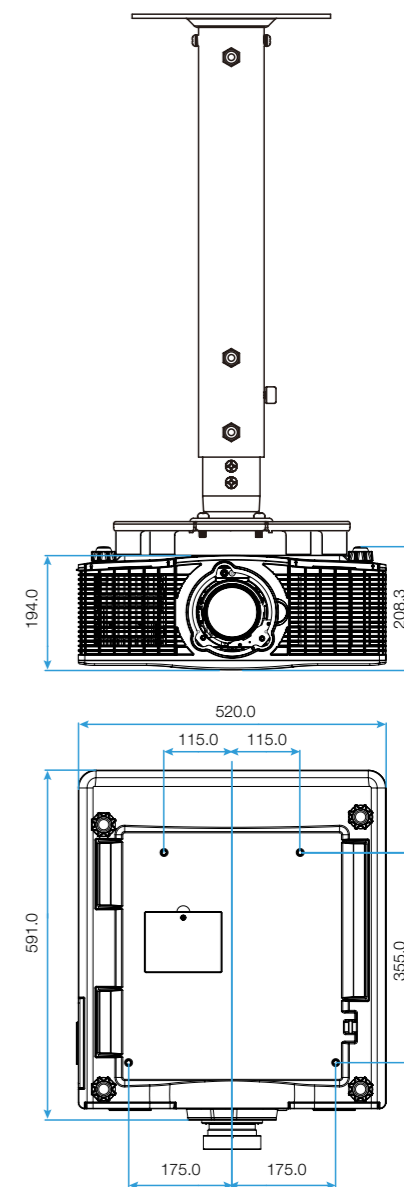



Offices

Worldwide technical and commercial support

Optoma Europe

Optoma Europe Ltd.

42 Caxton Way
The Watford Business Park
Watford
Hertfordshire
WD18 8QZ
UK
Tel: +44 (0) 1923 691 866

Optoma Deutschland GmbH

WIESENSTRASSE 21
D40549 Düsseldorf
Germany
Tel: +49 (0) 211 506 6670

Optoma France

Batiment E
81-83 avenue Edouard Vaillant
92100 Boulogne Billancourt
France
Tel. : +33 (0) 1 41 46 12 20

Optoma Spain

C/ José Hierro,36 Of. 1C
28529 Rivas Vaciamadrid
Madrid
Spain
Tel: +34 91 499 06 06

Optoma Benelux

Optoma Benelux BV
Randstad 22-123
1316 BW Almere
The Netherlands
Tel: +31 (0) 36 820 0252

Optoma Czech

Tel: +420608666090

Optoma Poland

Tel :+ 48 507 090 411

Optoma Romania

Tel: +40 723 764 995

Optoma Russia

Moscow
+7 905 553 67 78

Optoma Italy

+39 3408521552

Optoma Scandinavia

Lerpeveien 25
Postboks 9515 Åskollen
3038 Drammen
Norway
Tel: +47 32 98 89 90

Optoma Turkey

Tel: 07775 822134

Optoma UAE

Tel: 0097 155 574 8922

Optoma USA

Optoma USA Headquarters

3178 Laurelview Ct.
Fremont, CA 94538
Tel: (510) 897-8600

Optoma Asia

Taiwan

Optoma Corporation
Taipei Office
12F., No.213, Sec. 3, Beixin Rd., Xindian Dist., New Taipei City
231, Taiwan (R.O.C.)
Tel +886-2-8911-8600 EXT.3732

Taichung office

7F-5, No.3, Lane 2, 1st Rd, Taichung Industrial Park, Xitun
Dist., Taichung City, 40767, Taiwan, R.O.C.
Tel: +886-4-3505-0336

Kaohsiung office

Rm. D, 7F, No.108, Zhonghua 3rd Rd., Qianjin Dist.,
Kaohsiung City 80145, Taiwan, R.O.C.
Tel: +886-7-952-5689

China

Shanghai Office
5F, No. 1205 Kaixuan Road, Changning District, Shanghai
Tel: +86-21-6294-7376

Beijing office

20D apartment 3, Build No.3, Yindu Tower, No 48 ZhiChun
road, HaiDian district, Beijing
Tel: +86-10-5873-1919

ShenYang office

Room1201, building C3, Wulihe Tower, No 4-1 WenTi road,
HePing district, ShenYang
Tel: +86-024-3188-7018

Xi'an office

Room 1310, building B, ShiMao tower, GuanDongZheng
street, Xi'an
Tel: +86-029-8228-2428
Fax: +86-029-8228-2428

GungZhou office

Room 602, NanTie Tower, No.57 No.1ZhongShan road,
YueXiu district, GungZhou
Tel: +86-20-6128-0990 / 6128-1025

ChongQing office

Room 9-2, building 19 HuaYuMingDu, ShiQiaoPu, ChongQing
Tel: +86-23-6879-7626

ChengDu office

Room A3 floor 20, building A Time digital square, No.1 South
RenMin road, ChengDu
Tel: +86-28-8523-1553 / 8631-7092

Hong Kong office

Unit A, 27/F., Dragon Centre, 79 Wing Hong Street, Cheung
Sha Wan, Kowloon, Hong Kong
Tel: +852-2396-8968

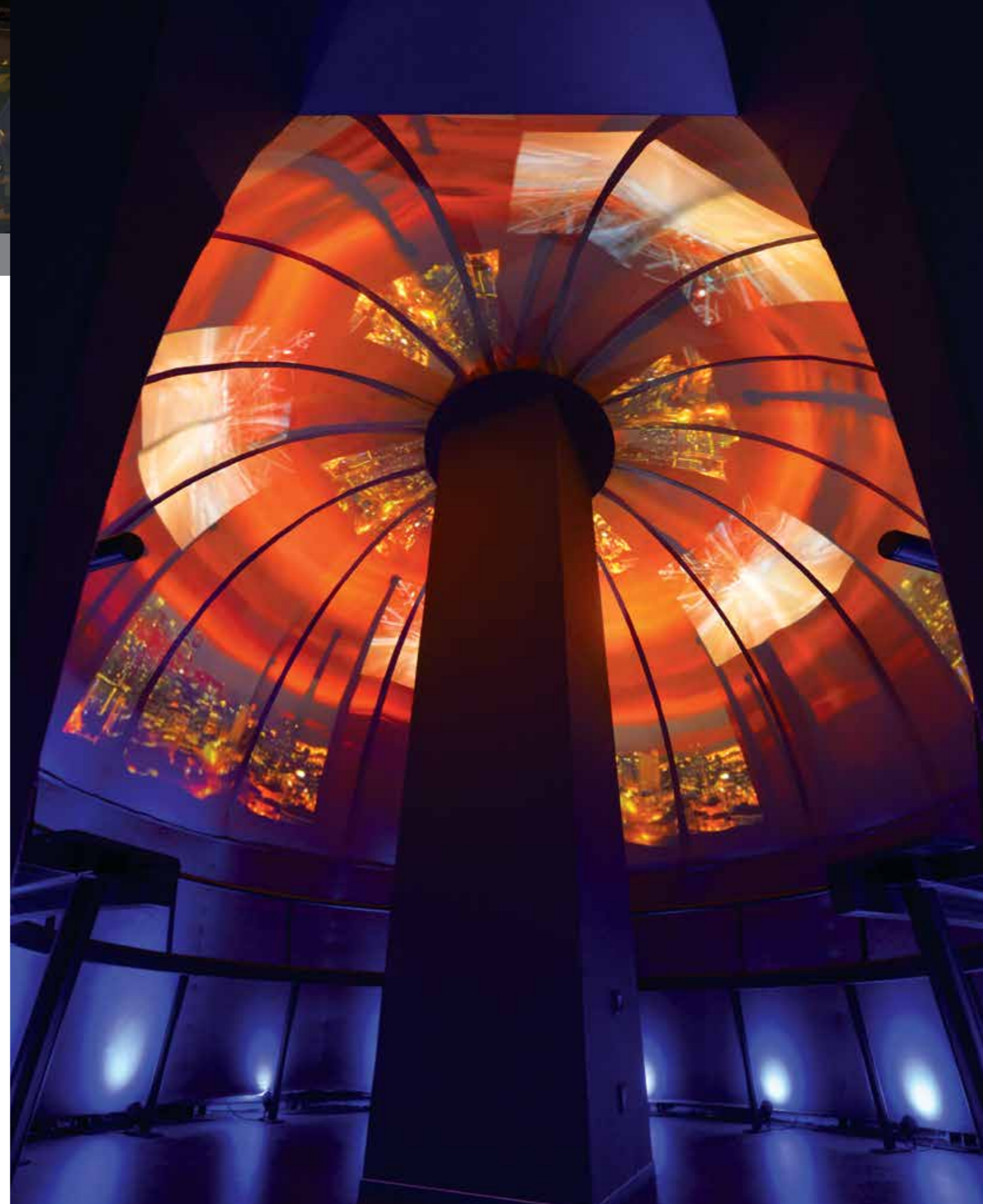

Copyright © 2015. Optoma and its logo is a registered trademark of Optoma Corporation. Optoma Europe Ltd is the licensee of the registered trademark. All other product names and company names used herein are for identification purposes only and may be trademarks or registered trademarks of their respective owners. DLP®, BrilliantColor™ and the DLP logo are registered trademarks of Texas Instruments. Crestron®, the Crestron and RoomView® logo are registered trademarks of Crestron Electronics, Inc. HDBaseT™ and the HDBaseT Alliance logo are trademarks of the HDBaseT Alliance. *Brightness and lifetime will vary depending on selected projector mode, environmental conditions and usage. As is common with all projectors, brightness will decrease over the lifetime. †Maximum light source lifetime achieved through testing will vary according to operational use and environmental conditions. ‡The quoted noise level is based on testing and will vary according to operational use and environmental conditions. Optoma guarantees that in normal use, Optoma DLP® colour quality will be indistinguishable from when new. Exclusions: (a) Guarantee is voided if the projector is subject to damage through misuse. (b) Guarantee may be void in industrial or commercial entertainment environments where dust or smoke is excessive (c) Guarantee will not apply if light source brightness is below 50% due to wear or if the projector is not working due to other faults. (d) Over time all light sources will show a slight colour variance. Errors and omissions excepted, all specifications are subject to change without notice. All images are for representation purposes only and may be simulated.



