



KRAMER ELECTRONICS LTD.

USER MANUAL

MODEL:

RTBUS-21
Round Table Connection Bus

P/N: 2900-300086 Rev 3



RTBUS-21 Quick Start Guide

This guide helps you install and use your product for the first time. For more detailed information, go to http://www.kramerelectronics.com/support/product_downloads.asp to download the latest manual or scan the QR code on the left.

Step 1: Check what's in the box

- RTBUS-21 Round Table Connection Bus
- 2 Mounting brackets
- 1 Quick Start guide

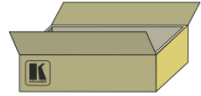

Save the original box and packaging materials in case you need to return your product for service.

Step 2: Cut an opening in the table

Drill an 110mm to 112mm (4.33in to 4.4in) hole in your table using a cup type drill bit.

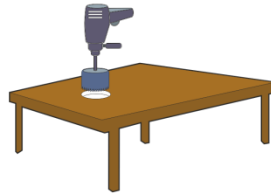

Step 3: Install the Connection BUS

A: Insert the Unit through the table opening.

B: Insert the mounting brackets.

E: Connect the Cables.

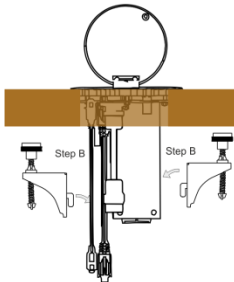

C, D: Secure the unit.

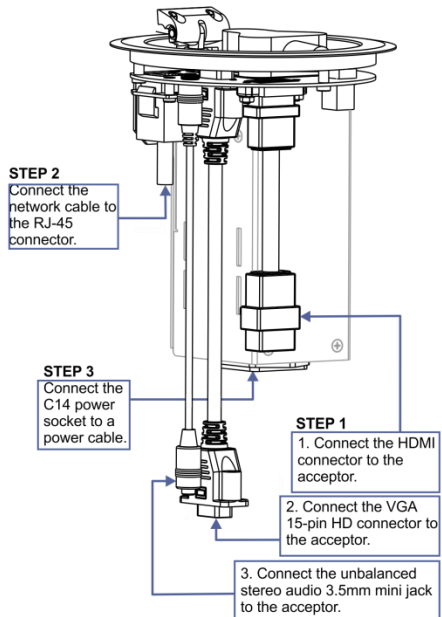
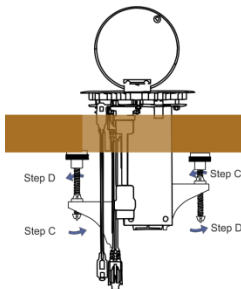

Contents

1	Introduction	1
2	Getting Started	2
2.1	Achieving the Best Performance	2
2.2	Safety Instructions	2
2.3	Recycling Kramer Products	3
3	Overview	4
4	Defining the RTBUS-21	5
4.1	The RTBUS-21 Connecting Surface	6
5	Installing the RTBUS-21	7
5.1	Drilling a Hole in the Table	7
5.2	Mounting the RTBUS-21 in the Table	8
5.3	Connecting the Cables and Wires	9
6	Using the RTBUS-21	10
7	Technical Specifications	11

Figures

Figure 1:	RTBUS-21 Top View	5
Figure 2:	RTBUS-21 Connecting Surface	6
Figure 3:	Connecting the Cables	9
Figure 4:	RTBUS-21 Boardroom Installation	10

1 Introduction

Welcome to Kramer Electronics! Since 1981, Kramer Electronics has been providing a world of unique, creative, and affordable solutions to the vast range of problems that confront video, audio, presentation, and broadcasting professionals on a daily basis. In recent years, we have redesigned and upgraded most of our line, making the best even better!

Our 1,000-plus different models now appear in 14 groups that are clearly defined by function: GROUP 1: Distribution Amplifiers; GROUP 2: Switchers and Routers; GROUP 3: Control Systems; GROUP 4: Format/Standards Converters; GROUP 5: Range Extenders and Repeaters; GROUP 6: Specialty AV Products; GROUP 7: Scan Converters and Scalers; GROUP 8: Cables and Connectors; GROUP 9: Room Connectivity; GROUP 10: Accessories and Rack Adapters; GROUP 11: Sierra Video Products; GROUP 12: Digital Signage; GROUP 13: Audio; and GROUP 14: Collaboration.

Thank you for purchasing the Kramer **RTBUS-21** Round Table Connection Bus, which is ideal for using in boardrooms, conference and training rooms!

2 Getting Started

We recommend that you:

- Unpack the equipment carefully and save the original box and packaging materials for possible future shipment
- Review the contents of this user manual



Go to http://www.kramerelectronics.com/support/product_downloads.asp to check for up-to-date user manuals, application programs, and to check if firmware upgrades are available (where appropriate).

2.1 Achieving the Best Performance

To achieve the best performance:

- Use only good quality connection cables (we recommend Kramer high-performance, high-resolution cables) to avoid interference, deterioration in signal quality due to poor matching, and elevated noise levels (often associated with low quality cables)
- Do not secure the cables in tight bundles or roll the slack into tight coils
- Avoid interference from neighboring electrical appliances that may adversely influence signal quality
- Position your Kramer **RTBUS-21** away from moisture, excessive sunlight and dust



This equipment is to be used only inside a building. It may only be connected to other equipment that is installed inside a building.

2.2 Safety Instructions



Caution: There are no operator serviceable parts inside the unit

Warning: Use only the power cord that is supplied with the unit

Warning: Do not open the unit. High voltages can cause electrical shock! Servicing by qualified personnel only

Warning: Disconnect the power and unplug the unit from the wall before installing

2.3 Recycling Kramer Products

The Waste Electrical and Electronic Equipment (WEEE) Directive 2002/96/EC aims to reduce the amount of WEEE sent for disposal to landfill or incineration by requiring it to be collected and recycled. To comply with the WEEE Directive, Kramer Electronics has made arrangements with the European Advanced Recycling Network (EARN) and will cover any costs of treatment, recycling and recovery of waste Kramer Electronics branded equipment on arrival at the EARN facility. For details of Kramer's recycling arrangements in your particular country go to our recycling pages at <http://www.kramerelectronics.com/support/recycling/>.

3 Overview

The **RTBUS-21** is an elegant furniture-mounted, round connection bus. The **RTBUS-21** features a pneumatic mechanism for pneumatic lifting and smooth closing of its lid. It is easily installed into a table or podium top, and its interface enables you to connect any equipment to systems installed in a room via the following pass-through connectors:

- 1 UXGA on a 15-pin HD connector
- 1 stereo audio on a 3.5mm connector
- 1 HDMI connector
- 1 Ethernet port on an RJ-45 connector
- C14 power socket

The **RTBUS-21** supports HDMI with Deep Color, x.v.Color™, Lip Sync, HDMI Uncompressed Audio Channels, Dolby TrueHD, DTS-HD, and CEC.

We offer the **RTBUS-21** in either a black anodized or a brushed clear aluminum surface.

4 Defining the RTBUS-21

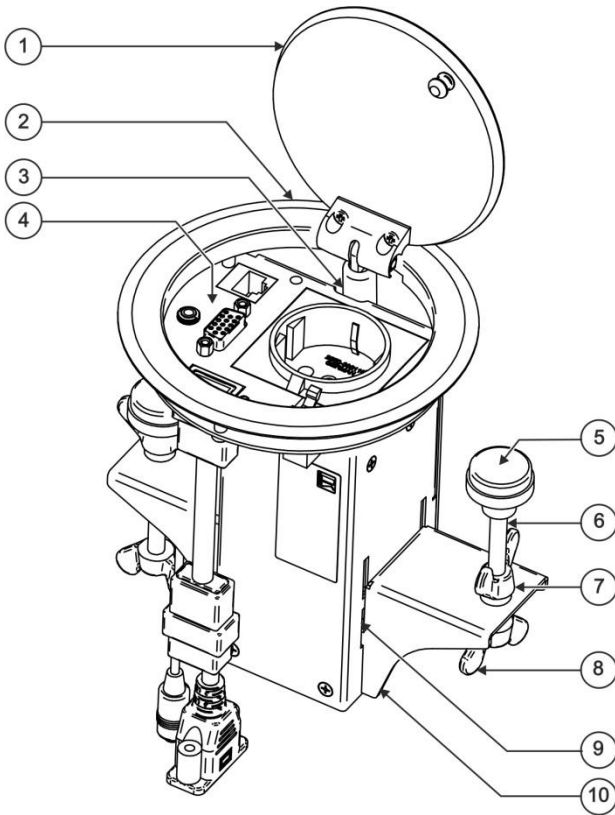

Figure 1: RTBUS-21 Top View

#	Feature	Function
1	Black anodized or brushed aluminum semi-automatic lid	Covers the connecting surface, leaving the table surface neat and tidy
2	Outer Rim	Fits over the table surface
3	Pneumatic Mechanism	Enables automatic lifting and smooth closing of the lid
4	Connecting Surface	See Figure 2
5	Rubber Protectors	Protect the table surface when mounting the unit (2)
6	Mounting Screws	For securing the RTBUS-21 to the table(2)
7	Locking Butterfly Nuts	Tighten to lock the mounting butterfly screw (2)
8	Mounting Butterfly Nuts	Tighten to secure the unit to the table surface (2)
9	Mounting Bracket Slits (two sets on each side)	Insert the mounting brackets to the slits when installing the RTBUS-21 (see Section 5.2).
10	Mounting Brackets (2 units)	Place in the bracket slits after inserting the enclosure into the table – for securing the unit to the table surface

4.1 The RTBUS-21 Connecting Surface

Figure 2 defines the connecting surface:

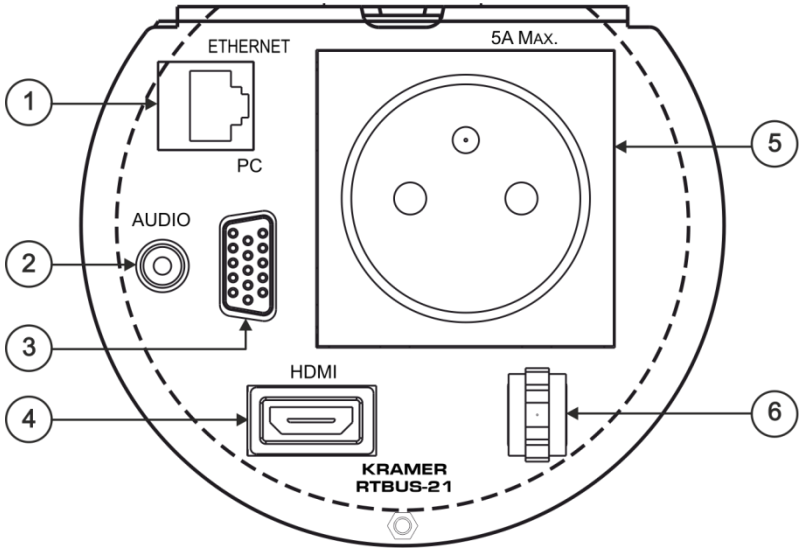

Figure 2: RTBUS-21 Connecting Surface

#	Feature	Function
1	ETHERNET RJ-45 Connector	Connect to a network
2	AUDIO 3.5mm Mini Jack	Connects to an unbalanced stereo audio source
3	PC 15-pin HD Connector	Connects to a VGA source
4	HDMI Connector	Connect to HDMI source
5	5A MAX. Power Socket	Connects to 90-240V AC power consuming device
6	Lid Latch	For safely closing the lid

5 Installing the RTBUS-21

To install the **RTBUS-21** perform the following steps:

1. Drill a hole in the table (see [Section 5.1](#)).
2. Insert the unit through the hole and secure the unit to the table (see [Section 5.2](#)).
3. Connect the cables (see [Section 5.3](#)).

5.1 Drilling a Hole in the Table

To drill an opening in the table:

1. Using any standard cup bit drill with a diameter ranging from 110mm to 112mm (4.33in to 4.4in), drill a hole in the table in the desired location.



The thickness of the table should be 3in (76mm) or less.

2. Clean the table surface.



Take care not to damage the table. Kramer Electronics is not responsible for any damage caused to the table.

5.2 Mounting the RTBUS-21 in the Table

To mount the unit, follow these steps:

Step 1: Insert the **RTBUS-21** into the hole cut into the table making sure the outer rim is firm against the surface of the table.

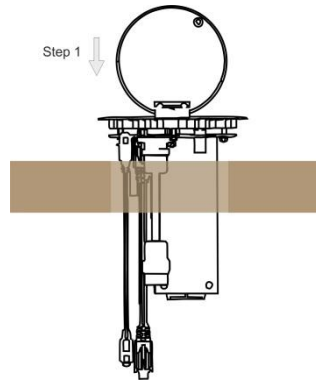

Step 2: From underneath the table, slide the mounting brackets into the appropriate slots.

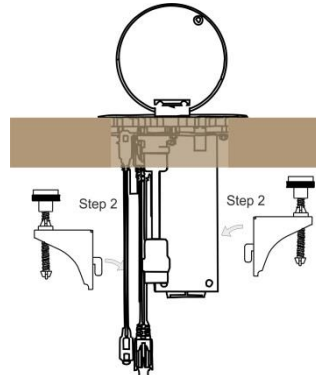

Step 3: Tighten the butterfly mounting screws securely upward against the table.

Step 4: Lock the mounting screws into position with the locking butterfly screws.

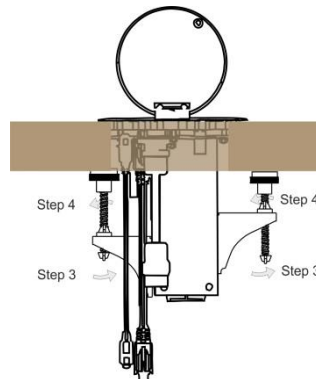

5.3 Connecting the Cables and Wires

Figure 3 illustrates how to connect the cables to the underside of the unit:

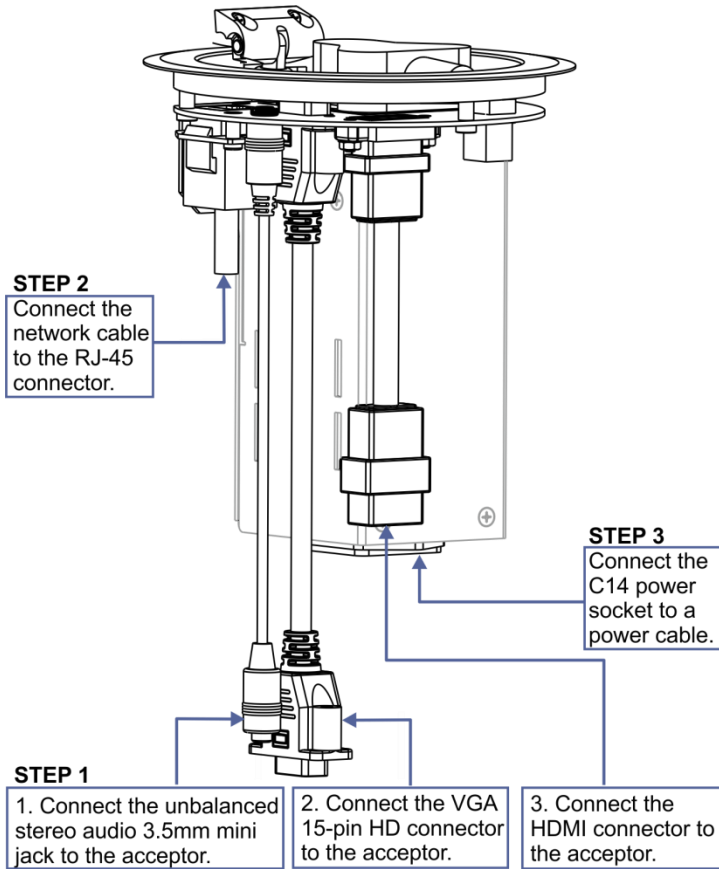

Figure 3: Connecting the Cables



Note that the cables shown in [Figure 3](#) are 50cm long and have a MALE connector at the free end so they can be plugged directly into the acceptors. You can extend these cables if required.

Note that the connecting surface is an integral part of the **RTBUS-21** enclosure and cannot be detached.

We recommend that you use the Kramer **C-AC** AC Power Cord series to power the unit.

6 Using the RTBUS-21

Once the **RTBUS-21** is installed, you can easily customize it to your own needs by directly plugging in the required AV equipment, as illustrated in the example in [Figure 4](#).

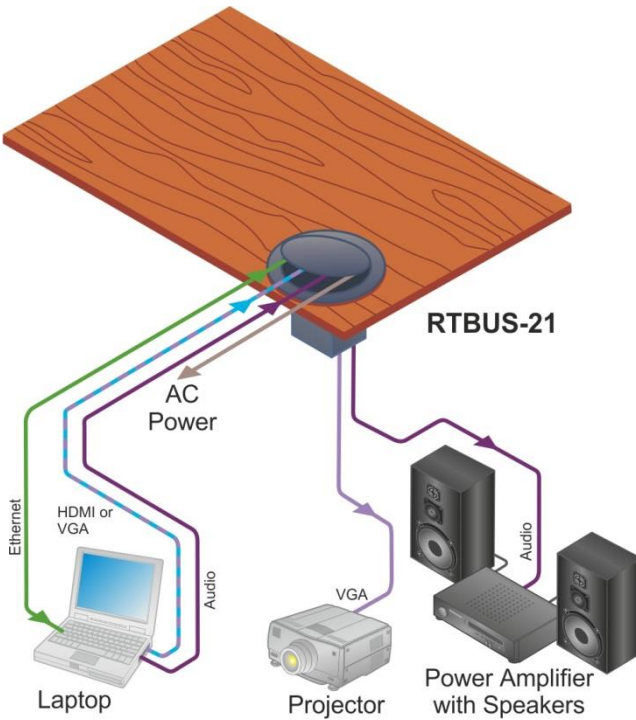

Figure 4: RTBUS-21 Boardroom Installation

7 Technical Specifications

PORTS:	1 HDMI connector, 1 15-pin HD connector, 1 3.5mm mini jack, 1 RJ-45 connector
OPERATING TEMPERATURE:	0° to +40°C (32° to 104°F)
STORAGE TEMPERATURE:	-40° to +70°C (-49° to 158°F)
HUMIDITY:	10% to 90%, RHL non-condensing
POWER SOURCE (AC power limits):	90-240V AC, 50/60Hz, 5A Max
FUSE RATING:	T 6.3A 250V
DIMENSIONS:	13cm x 16cm (5.1" x 6.3") Diameter, H
WEIGHT:	0.85kg (1.9lbs) approx. 1.2kg (2.6lbs) approx. with mounting brackets
Specifications are subject to change without notice at http://www.kramerelectronics.com	

LIMITED WARRANTY

The warranty obligations of Kramer Electronics for this product are limited to the terms set forth below:

What is Covered

This limited warranty covers defects in materials and workmanship in this product.

What is Not Covered

This limited warranty does not cover any damage, deterioration or malfunction resulting from any alteration, modification, improper or unreasonable use or maintenance, misuse, abuse, accident, neglect, exposure to excess moisture, fire, improper packing and shipping (such claims must be presented to the carrier), lightning, power surges, or other acts of nature. This limited warranty does not cover any damage, deterioration or malfunction resulting from the installation or removal of this product from any installation, any unauthorized tampering with this product, any repairs attempted by anyone unauthorized by Kramer Electronics to make such repairs, or any other cause which does not relate directly to a defect in materials and/or workmanship of this product. This limited warranty does not cover cartons, equipment enclosures, cables or accessories used in conjunction with this product.

Without limiting any other exclusion herein, Kramer Electronics does not warrant that the product covered hereby, including, without limitation, the technology and/or integrated circuit(s) included in the product, will not become obsolete or that such items are or will remain compatible with any other product or technology with which the product may be used.

How Long Does this Coverage Last

Seven years as of this printing; please check our Web site for the most current and accurate warranty information.

Who is Covered

Only the original purchaser of this product is covered under this limited warranty. This limited warranty is not transferable to subsequent purchasers or owners of this product.

What Kramer Electronics will do

Kramer Electronics will, at its sole option, provide one of the following three remedies to whatever extent it shall deem necessary to satisfy a proper claim under this limited warranty:

1. Elect to repair or facilitate the repair of any defective parts within a reasonable period of time, free of any charge for the necessary parts and labor to complete the repair and restore this product to its proper operating condition. Kramer Electronics will also pay the shipping costs necessary to return this product once the repair is complete.
2. Replace this product with a direct replacement or with a similar product deemed by Kramer Electronics to perform substantially the same function as the original product.
3. Issue a refund of the original purchase price less depreciation to be determined based on the age of the product at the time remedy is sought under this limited warranty.

What Kramer Electronics will not do Under This Limited Warranty

If this product is returned to Kramer Electronics or the authorized dealer from which it was purchased or any other party authorized to repair Kramer Electronics products, this product must be insured during shipment, with the insurance and shipping charges prepaid by you. If this product is returned uninsured, you assume all risks of loss or damage during shipment. Kramer Electronics will not be responsible for any costs related to the removal or re-installation of this product from or into any installation. Kramer Electronics will not be responsible for any costs related to any setting up this product, any adjustment of user controls or any programming required for a specific installation of this product.

How to Obtain a Remedy under this Limited Warranty

To obtain a remedy under this limited warranty, you must contact either the authorized Kramer Electronics reseller from whom you purchased this product or the Kramer Electronics office nearest you. For a list of authorized Kramer Electronics resellers and/or Kramer Electronics authorized service providers, please visit our web site at www.kramerelectronics.com or contact the Kramer Electronics office nearest you.

In order to pursue any remedy under this limited warranty, you must possess an original, dated receipt as proof of purchase from an authorized Kramer Electronics reseller. If this product is returned under this limited warranty, a return authorization number, obtained from Kramer Electronics, will be required. You may also be directed to an authorized reseller or a person authorized by Kramer Electronics to repair the product.

If it is decided that this product should be returned directly to Kramer Electronics, this product should be properly packed, preferably in the original carton, for shipping. Cartons not bearing a return authorization number will be refused.

Limitation on Liability

THE MAXIMUM LIABILITY OF KRAMER ELECTRONICS UNDER THIS LIMITED WARRANTY SHALL NOT EXCEED THE ACTUAL PURCHASE PRICE PAID FOR THE PRODUCT. TO THE MAXIMUM EXTENT PERMITTED BY LAW, KRAMER ELECTRONICS IS NOT RESPONSIBLE FOR DIRECT, SPECIAL, INCIDENTAL OR CONSEQUENTIAL DAMAGES RESULTING FROM ANY BREACH OF WARRANTY OR CONDITION, OR UNDER ANY OTHER LEGAL THEORY. Some countries, districts or states do not allow the exclusion or limitation of relief, special, incidental, consequential or indirect damages, or the limitation of liability to specified amounts, so the above limitations or exclusions may not apply to you.

Exclusive Remedy

TO THE MAXIMUM EXTENT PERMITTED BY LAW, THIS LIMITED WARRANTY AND THE REMEDIES SET FORTH ABOVE ARE EXCLUSIVE AND IN LIEU OF ALL OTHER WARRANTIES, REMEDIES AND CONDITIONS, WHETHER ORAL OR WRITTEN, EXPRESS OR IMPLIED. TO THE MAXIMUM EXTENT PERMITTED BY LAW, KRAMER ELECTRONICS SPECIFICALLY DISCLAIMS ANY AND ALL IMPLIED WARRANTIES, INCLUDING, WITHOUT LIMITATION, WARRANTIES OF MERCHANTABILITY AND FITNESS FOR A PARTICULAR PURPOSE. IF KRAMER ELECTRONICS CANNOT LAWFULLY DISCLAIM OR EXCLUDE IMPLIED WARRANTIES UNDER APPLICABLE LAW, THEN ALL IMPLIED WARRANTIES COVERING THIS PRODUCT, INCLUDING WARRANTIES OF MERCHANTABILITY AND FITNESS FOR A PARTICULAR PURPOSE, SHALL APPLY TO THIS PRODUCT AS PROVIDED UNDER APPLICABLE LAW.

IF ANY PRODUCT TO WHICH THIS LIMITED WARRANTY APPLIES IS A "CONSUMER PRODUCT" UNDER THE MAGNUSON-MOSS WARRANTY ACT (15 U.S.C.A. §2301, ET SEQ.) OR OTHER APPLICABLE LAW, THE FOREGOING DISCLAIMER OF IMPLIED WARRANTIES SHALL NOT APPLY TO YOU, AND ALL IMPLIED WARRANTIES ON THIS PRODUCT, INCLUDING WARRANTIES OF MERCHANTABILITY AND FITNESS FOR THE PARTICULAR PURPOSE, SHALL APPLY AS PROVIDED UNDER APPLICABLE LAW.

Other Conditions

This limited warranty gives you specific legal rights, and you may have other rights which vary from country to country or state to state.

This limited warranty is void if (i) the label bearing the serial number of this product has been removed or defaced, (ii) the product is not distributed by Kramer Electronics or (iii) this product is not purchased from an authorized Kramer Electronics reseller. If you are unsure whether a reseller is an authorized Kramer Electronics reseller, please visit our Web site at www.kramerelectronics.com or contact a Kramer Electronics office from the list at the end of this document.

Your rights under this limited warranty are not diminished if you do not complete and return the product registration form or complete and submit the online product registration form. Kramer Electronics thanks you for purchasing a Kramer Electronics product. We hope it will give you years of satisfaction.



For the latest information on our products and a list of Kramer distributors, visit our Web site where updates to this user manual may be found.

We welcome your questions, comments, and feedback.

Web site: www.kramerelectronics.com

E-mail: info@kramerel.com



SAFETY WARNING

Disconnect the unit from the power supply before opening and servicing



P/N: 2900-300086



Rev: 3