

Kramer Electronics, Ltd.



USER MANUAL

Room Controller Models:

RC-62 Series (RC-62, RC-62L)

RC-63A Series (RC-63A, RC-63AL)

RC-63D Series (RC-63D, RC-63DL)

Contents

1	Introduction	1
2	Getting Started	2
3	Overview	2
4	Installing the Room Controller	3
4.1	Defining the RC-62 and RC-62L	4
4.2	Defining the RC-63A and RC-63AL	6
4.3	Defining the RC-63D and RC-63DL	9
5	Using Your Room Controller	11
5.1	Operating the Room Controller	15
5.2	Using the Macro Buttons	15
6	Customizing the Controllers' Buttons and Labels	16
6.1	Button Labels	16
6.2	Inserting the Button Labels	17
6.3	Replacing a Button Label	17
6.4	Grounding the Room Controller	18
7	Technical Specifications	19

Figures

Figure 1:	RC-62 Room Controller Front Panel	4
Figure 2:	RC-62 Room Controller Rear Panel	5
Figure 3:	RC-63A Room Controller Front Panel (for Europe)	8
Figure 4:	RC-63A Room Controller Rear Panel (for Europe)	8
Figure 5:	RC-63D Room Controller Front Panel	10
Figure 6:	RC-63D Room Controller Rear Panel	10
Figure 7:	RC-63D Master/Standalone Power Supply Pinout	12
Figure 8:	Example of a Typical Standalone RC-63DL Configuration	13
Figure 9:	RC-63D connected to the SV-551 SummitView™ Processor / Switcher	14
Figure 10:	RC-63DL Labels Setup	15
Figure 11:	Sample “Button Labels” Sheet	16
Figure 12:	Unscrewing the Faceplate Attachment Screws	17
Figure 13:	Grounding Connection Components	18

Tables

Table 1: Defining the Room Controllers' Series	1
Table 2: RC-62 Front Panel Features	4
Table 3: RC-62 Rear Panel Features	5
Table 4: Defining the RC-63A (for the USA)	7
Table 5: RC-63A/EU Front Panel Features (for Europe)	8
Table 6: RC-63A/EU Rear Panel Features	9
Table 7: RC-63D Front Panel Features	10
Table 8: RC-63D Rear Panel Features	11
Table 9: Room Controller Functions and Characteristics	12
Table 10: Connection Scheme (for the example in Figure 8)	13
Table 11: The Commands Configuration	15
Table 12: Grounding Component Descriptions	18
Table 13: Technical Specifications of the Room Controller Series	19
Table 14: Available RC-6X Models	20

ADDENDUM to the RC-62, RC-63A and RC-63D Series User Manual (P/N: 2900-000473)

The new **RC-62X**, **RC-63AX** and **RC-63DX** room controller models are designed for use in control applications in which group labels are not required; they have the same functionality as the **RC-62**, **RC-63A** and **RC-63D**, respectively.

The RC-62X Room Controller:

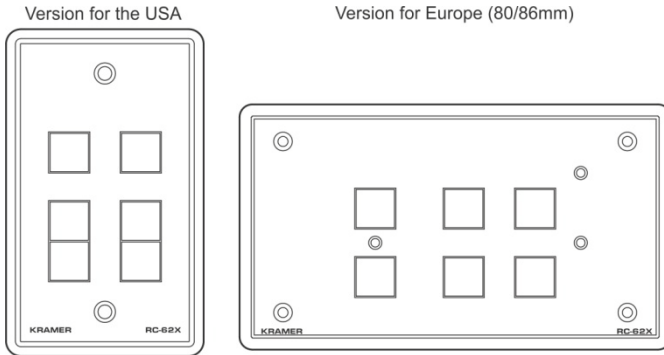

The RC-63AX Room Controller:

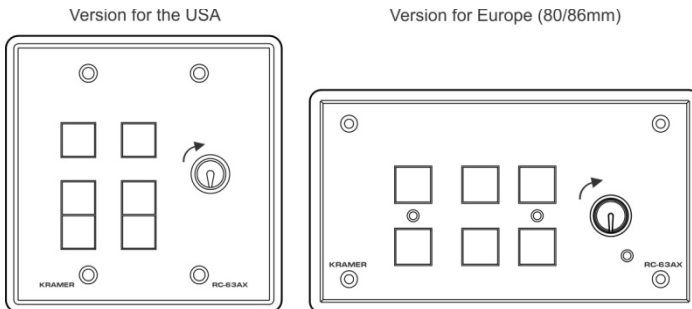

The RC-63DX Room Controller:

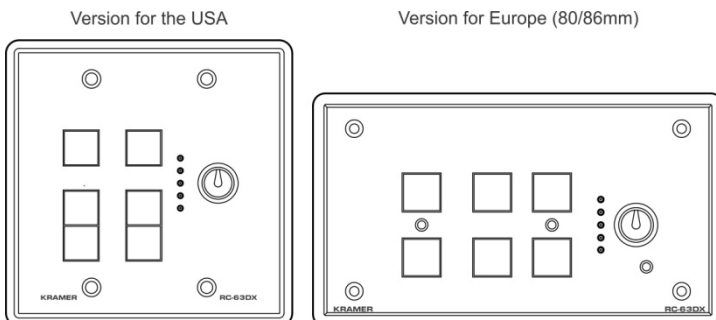

This addendum describes the process of mounting a two-gang wall plate using the frame adapter.

Mounting the Wall Plate

Figure 1 illustrates how to mount the two-gang wall plate:

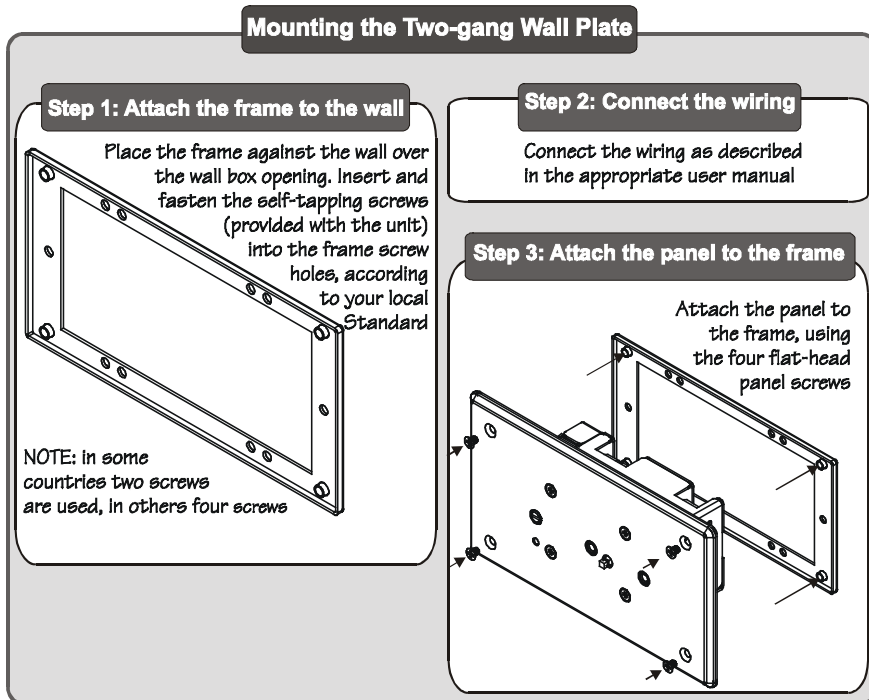

Figure 1: Mounting the Two-gang Wall Plate



P/N: 2900-0060192

1 Introduction

Welcome to Kramer Electronics! Since 1981, Kramer Electronics has been providing a world of unique, creative, and affordable solutions to the vast range of problems that confront the video, audio, presentation, and broadcasting professional on a daily basis. In recent years, we have redesigned and upgraded most of our line, making the best even better! Our 1,000-plus different models now appear in 11 groups¹ that are clearly defined by function.

Congratulations on purchasing your Kramer **RC-62** and/or **RC-63A** and/or **RC-63D** room controller (defined in [Table 1](#)), which are available in European (80mm and 86mm height versions) and American versions.

Table 1: Defining the Room Controllers' Series²

	LCD Group-Labels ³	Printed Group-Labels ⁴
RC-62 Series	RC-62L	RC-62
RC-63A series With a separate analog volume control adjustment knob	RC-63AL	RC-63A
RC-63D Series With a separate digital volume control adjustment knob	RC-63DL	RC-63D

The *Room Controllers* are designed to let you control an A/V system with ease—such as our *SummitView*TM kits⁵—in a multimedia classroom or conference room.

1 GROUP 1: Distribution Amplifiers; GROUP 2: Switchers and Matrix Switchers; GROUP 3: Control Systems; GROUP 4: Format/Standards Converters; GROUP 5: Range Extenders and Repeaters; GROUP 6: Specialty AV Products; GROUP 7: Scan Converters and Scalers; GROUP 8: Cables and Connectors; GROUP 9: Room Connectivity; GROUP 10: Accessories and Rack Adapters; GROUP 11: Sierra Products

2 The specific model is not printed on the unit. For example, RC-63DL (with LCD labels) has RC-63D printed on it and can be recognized by the LCD displays on its panel

3 Has LCD labels, letting you program the required group-label

4 The DISPLAY and SOURCES labels are printed on the unit

5 SummitViewTM is a complete and simple solution for the integration of media and control in classrooms, training rooms and presentation rooms. SummitViewTM is as easy-to-use as it is to specify and install. Everything required, including wall plate interfaces, controllers, amplifiers, speakers, cable and even enclosures ready to be mounted to projection mounts is included. With SummitViewTM you get everything you need for a high end integrated media system – just add the displays and sources. All the signals are transmitted over economical CAT 5 cable

The room controllers—**RC-62**, **RC-63A** and **RC-63D**—can be used as:

- System controllers for the *SummitView*TM system when connected via K-NET¹ cable to the **SV-551** or **SV-552** *SummitView*TM Processor / Switcher. When used in this way, no programming of these units is needed and the unit does not require a separate power supply
- Advanced, standalone, wall-mounted room controllers. When used in this way, programming of these units is required² as well as a separate power supply

The package includes the following items:

- Any version of the **RC-62** series, the **RC-63A** series or the **RC-63D** series
- 3' (0.91m) USB cable³
- Screwdriver
- Power adapter: 12V DC Input
- This user manual⁴
- Configuration software⁵ (K-Config)

2 Getting Started

This user manual is written for the end user. Refer to the separate Configuration Software Guide (available online) for details of how to install and configure the Room Controller⁶

We recommend that you review the contents of this user manual.

3 Overview

This user manual describes the **RC-62 / RC-63A / RC-63D** series.

Each of these highly versatile controller interfaces acts as an all-in-one extended remote control panel for control of A/V equipment—especially projectors and associated equipment—in any room (such as classrooms, boardrooms, or auditoriums). They streamline operations and simplify control by integrating audio, video, and computer-video sources into a centralized system.

1 K-NET is a proprietary Kramer protocol for interconnecting Kramer units

2 Refer to the separate online “Configuration Software Guide” at <http://www.kramerelectronics.com>

3 Part number C-UA/MUB-3

4 Download up-to-date Kramer user manuals from the Internet at this URL: <http://www.kramerelectronics.com>

5 The relevant configuration software varies according to the firmware version in use. For details, go to our Web site at <http://www.kramerelectronics.com>

6 That provides information about how to set up the system. This online guide may well be updated on a regular basis. For the latest online guide, go to <http://www.kramerelectronics.com>

Each room controller includes:

- Configurable backlit¹ buttons to set up any supported² command
- A bidirectional RS-232 wired serial port, for universal display (for example, projectors) and switcher control
- Two K-NET ports
- Two relays for the simplified and centralized control of room functions (such as lighting, closing blinds, screen settings, and so on)
- An IR control port
- An IR-learner for the customized control of external sources, receiving the IR commands from different remote transmitters without the need for an external IR remote control unit
- Macro mode operation, for programming multiple commands with the press of a single button
- Support for firmware upgrade via USB

In addition, the **RC-63A** and the **RC-63D** feature a separate analog and digital volume adjustment knob, respectively.

To achieve the best performance:

- Connect only good quality connection cables, thus avoiding interference, deterioration in signal quality due to poor matching, and elevated noise-levels (often associated with low quality cables)
- Avoid interference from neighboring electrical appliances and position your *Kramer Room Controller* away from moisture, excessive sunlight and dust

	Caution: No operator serviceable parts inside unit
	Warning: Use only the Kramer Electronics input power wall adapter that is provided with the unit
	Warning: Disconnect power and unplug unit from wall before installing or removing the device or servicing unit

4 Installing the Room Controller

This section defines the:

- **RC-62**, and **RC-62L**, see section [4.1](#)
- **RC-63A** and **RC-63AL**, see section [4.2](#)
- **RC-63D** and **RC-63DL**, see section [4.3](#)

¹ 256 colors are available for backlit buttons (to be configured by the system integrator)

² To be configured by the system integrator only

4.1 Defining the RC-62 and RC-62L

The **RC-62** is available as a 1 Gang wall plate (for the USA) or a 2 Gang wall plate (for Europe). It features 6 front panel buttons designed in two groups; one group of 2 buttons, and another group of 4 buttons. Each group can be programmed according to the user's requirements. The:

- **RC-62** has the **DISPLAY** and **SOURCES** labels printed on the unit
- **RC-62L** has an LCD label, letting you program the required group label

The **RC-62** series includes two relays for the simplified and centralized control of room functions (such as lighting, closing blinds, screen settings, and so on), an IR output, a bidirectional RS-232 port, and two K-NET ports. In addition, the **RC-62** features an IR-learner for the customized control of external sources, memorizing the IR commands from different remote transmitters. A USB port is included for programming the **RC-62** via a computer.

[Figure 1](#), [Figure 2](#), [Table 2](#) and [Table 3](#) define the **RC-62**, and **RC-62L**.

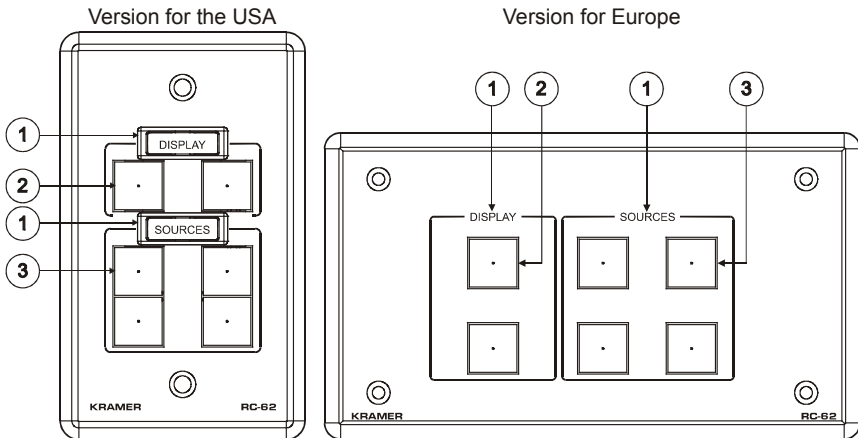

Figure 1: RC-62 Room Controller Front Panel¹

Table 2: RC-62 Front Panel Features

#	Feature	Function
1	"DISPLAY" and "SOURCE" Labels	RC-62 - "DISPLAY" and "SOURCE" are printed on the panel RC-62L - an LCD version on a blue background that displays up to 8 characters at once (programmed via the USB port)
2	DISPLAY Buttons	These 2 configurable backlit buttons can set up any supported command ²
3	SOURCE Buttons	These 4 configurable backlit buttons can set up any supported command ²

¹ The USA version shown has LCD Labels (RC-62L), and the European version shown has printed labels (RC-62)

² By the system integrator only

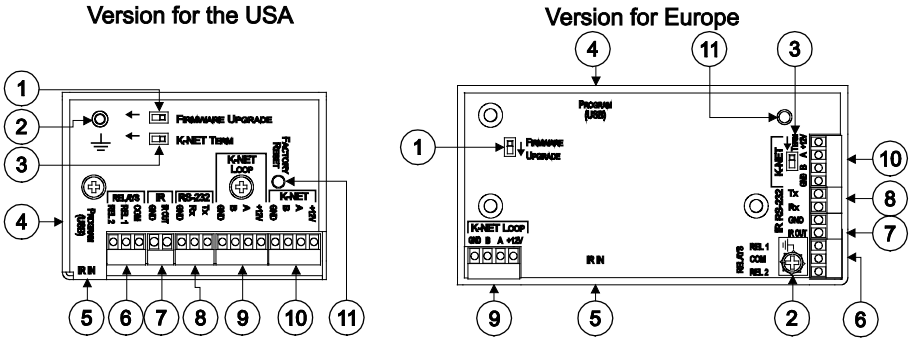

Figure 2: RC-62 Room Controller Rear Panel

Table 3: RC-62 Rear Panel Features

#	Feature	Function
1	FIRMWARE UPGRADE Switch	For technical support use only
2	Grounding Screw	Connect to grounding wire (optional), see section 6.4
3	K-NET TERM Switch	For line termination
4	PROGRAM (USB) Connector	Connect to a computer for unit configuration
5	IR IN Receiver	Receives IR remote commands
6	RELAYS Connections	Connect to room items (such as lighting, screen settings, blinds, and so on)
7	IR Connections	Control a machine via an IR Emitter
8	RS-232 Connections	Connect to the RS-232 connector on the A/V equipment or a PC or other Serial Controller
9	K-NET LOOP Connections	On K-NET and K-NET LOOP, PIN GND is for the Ground connection ¹ ; PIN B (-) and PIN A (+) are for RS-485, and PIN +12V is for powering the unit
10	K-NET Connections	
11	FACTORY RESET Button	Press to revert to the default settings, including all the configured buttons

¹ The ground connection is sometimes connected to the shield of the RS-485 cable (in most applications, it is not connected)

4.2 Defining the RC-63A and RC-63AL

The Kramer **RC-63A** is available as a 2 Gang wall plate (for Europe and the USA). It features 6 front panel buttons designed in two groups; one group of 2 buttons, and another group of 4 buttons. Each group can be programmed according to the user's requirements. The:

- **RC-63A** has the DISPLAY and SOURCES labels printed on the unit
- **RC-63AL** has LCD labels, letting you program the required group label, as well as rolling text on the display

The **RC-63A** also includes:

- An analog volume control adjustment knob
- Two relays for the simplified and centralized control of room functions (such as lighting, closing blinds, screen settings, and so on)
- An IR output, a bidirectional RS-232 port, and two K-NET ports
- An IR-learner for the customized control of external sources, memorizing the IR commands from different remote transmitters

A USB port is included for programming the **RC-63A** via a computer.

[Table 4](#) defines the **RC-63** and **RC-63AL**.

Installing the Room Controller

Table 4: Defining the RC-63A (for the USA)

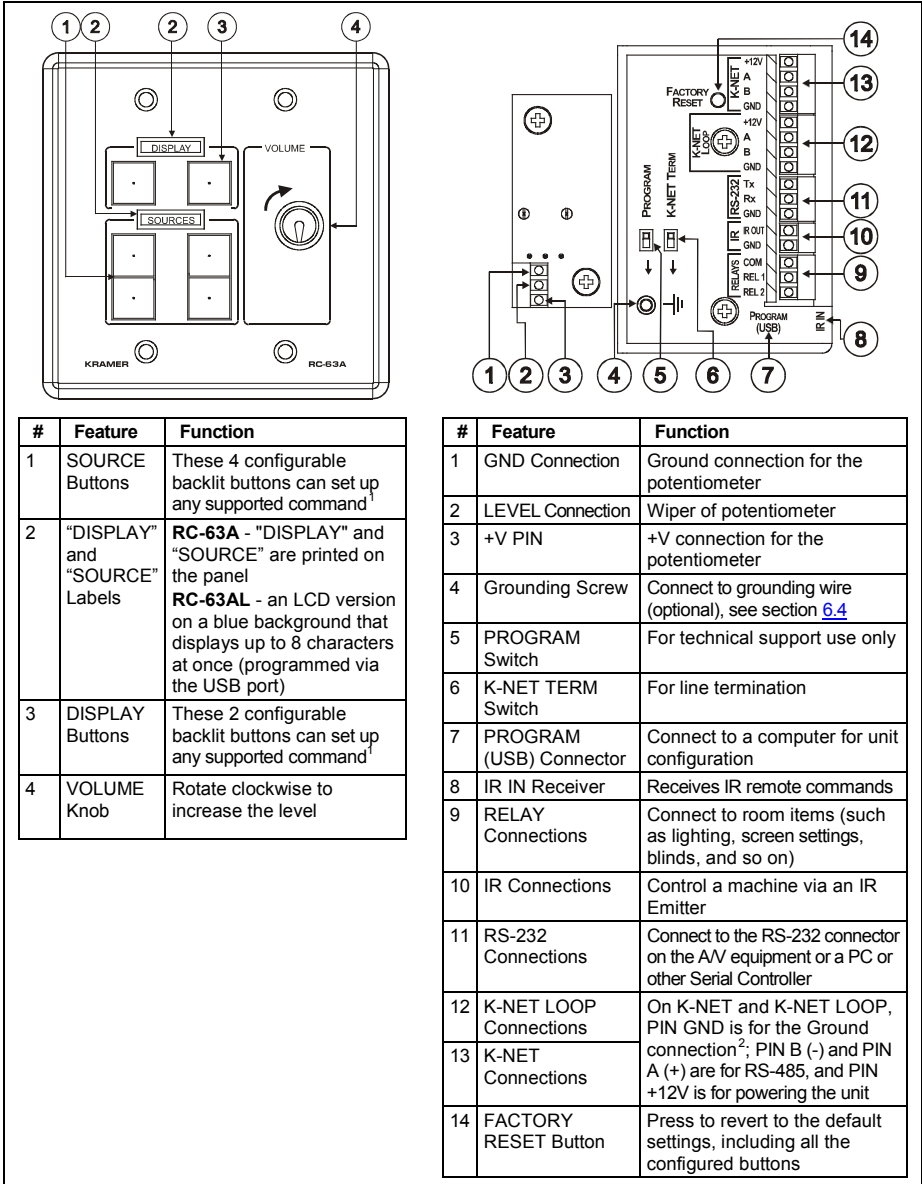

¹ By the system integrator only

² The ground connection is sometimes connected to the shield of the RS-485 cable (in most applications, it is not connected)

[Figure 3](#) and [Table 5](#) define the **RC-63A** and the **RC-63AL** front panels (for Europe):

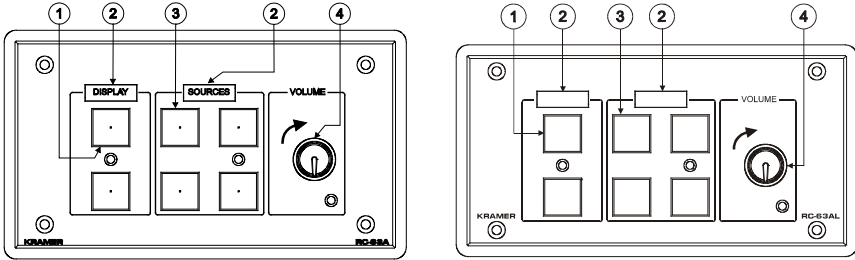

Figure 3: RC-63A Room Controller Front Panel (for Europe)

Table 5: RC-63A/EU Front Panel Features (for Europe)

#	Feature	Function
1	DISPLAY Buttons	These 2 configurable backlit buttons can set up any supported command
2	"DISPLAY" and "SOURCE" Labels	RC-63A - "DISPLAY" and "SOURCE" are printed on the panel RC-63AL - an LCD version on a blue background that displays up to 8 characters at once (programmed via the USB port)
3	SOURCE Buttons	These 4 configurable backlit buttons can set up any supported command
4	VOLUME Knob	Rotate clockwise to increase the level

[Figure 4](#) and [Table 6](#) define the **RC-63A** Rear panel (for Europe):

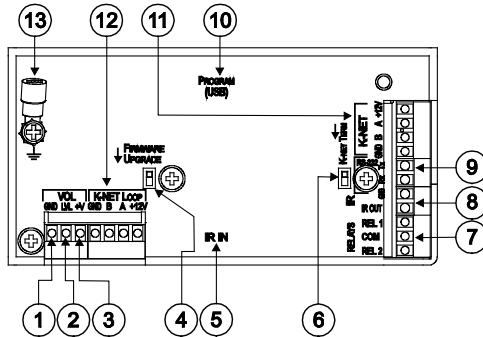

Figure 4: RC-63A Room Controller Rear Panel (for Europe)

Table 6: RC-63A/EU Rear Panel Features

#	Feature	Function
1	GND Connection	Ground connection for the potentiometer
2	LVL (LEVEL) Connection	Wiper of potentiometer
3	+V PIN	+V connection for the potentiometer
4	FIRMWARE UPGRADE Switch	For technical support use only
5	IR IN Receiver	Receives IR remote commands
6	K-NET TERM Switch	For line termination
7	RELAY Connections	Connect to room items (such as lighting, screen settings, blinds, and so on)
8	IR Connections	Control a machine via an IR Emitter
9	RS-232 Connections	Connect to the RS-232 connector on the AV equipment or a PC or other Serial Controller
10	PROGRAM (USB) Connector	Connect to a computer for unit configuration
11	K-NET Connections	On K-NET and K-NET LOOP, PIN GND is for the Ground connection ¹ ;
12	K-NET LOOP Connections	PIN B (-) and PIN A (+) are for RS-485, and PIN +12V is for powering the unit
13	Grounding Screw	Connect to grounding wire (optional), see section 6.4

4.3 Defining the RC-63D and RC-63DL

The Kramer **RC-63D** is available as a 2 Gang wall plate for the USA or a 2 Gang wall plate for Europe. It features 6 front panel buttons designed in two groups; one group of 2 buttons, and another group of 4 buttons. Each group can be programmed according to the user's requirements. The:

- **RC-63D** has the DISPLAY and SOURCES labels printed on the unit
- **RC-63DL** is the default room controller included as part of the *SummitView™ Standard Kit Box* and the *SummitView™ Essentials Kit Box* and described in that user manual, and has an LCD label, letting you program the required group label, as well as rolling text on the display

The **RC-63D** also includes:

- A configurable digital volume control adjustment knob with five LEDs
- Two relays for the simplified and centralized control of room functions (such as lighting, closing blinds, screen settings, and so on)
- An IR output, a bidirectional RS-232 port, and two K-NET ports
- An IR-learner for the customized control of external sources, memorizing the IR commands from different remote transmitters

A USB port is included for programming the **RC-63D** via a computer.

[Figure 5](#), [Figure 6](#), [Table 7](#) and [Table 8](#) define the **RC-63D** and **RC-63DL**.

¹ The ground connection is sometimes connected to the shield of the RS-485 cable (in most applications, it is not connected)

Installing the Room Controller

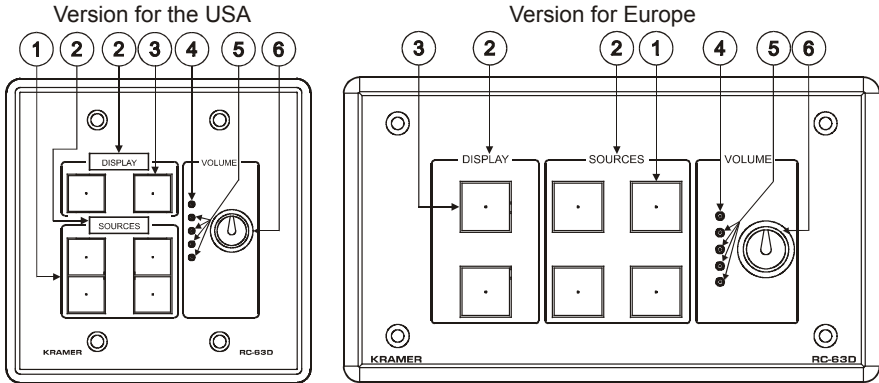

Figure 5: RC-63D Room Controller Front Panel

Table 7: RC-63D Front Panel Features

#	Feature	Function
1	SOURCE Buttons	These 4 configurable backlit buttons can set up any supported command ¹
2	“DISPLAY” and “SOURCE” Labels	RC-63D - “DISPLAY” and “SOURCE” are printed on the panel RC-63DL - an LCD version on a blue background that displays up to 8 characters at once (programmed via the USB port)
3	DISPLAY Buttons	These 2 configurable backlit buttons can set up any supported command ¹
4	VOLUME LED	Lights red, indicating maximum volume
5	VOLUME LEDs	Lights green, indicating volume level
6	VOLUME Knob	Rotate clockwise to increase the level

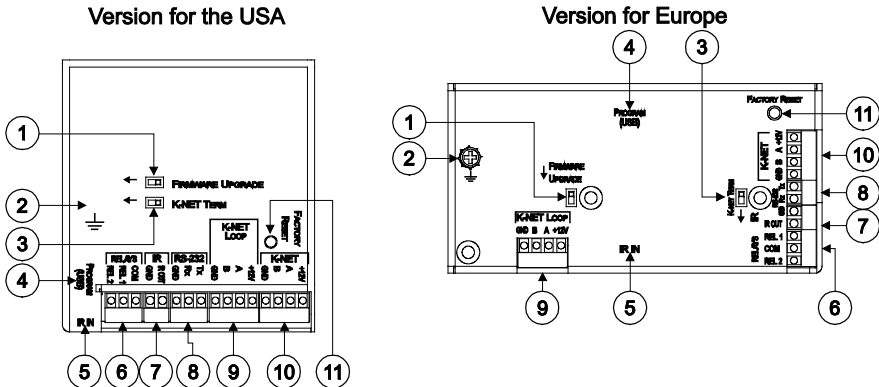

Figure 6: RC-63D Room Controller Rear Panel

¹ By the system integrator only

Table 8: RC-63D Rear Panel Features

#	Feature	Function
1	FIRMWARE UPGRADE Switch	For technical support use only
2	Grounding Screw	Connect to grounding wire (optional), see section 6.4
3	K-NET TERM Switch	For line termination
4	PROGRAM (USB) Connector	Connect to a computer for unit configuration
5	IR IN Receiver	Receives IR remote commands
6	RELAY Connections	Connect to room items (such as lighting, screen settings, and so on)
7	IR Connections	Control a machine via an IR Emitter
8	RS-232 Connections	Connect to the RS-232 connector on the A/V equipment or a PC or other Serial Controller
9	K-NET LOOP Connections	On K-NET and K-NET LOOP, PIN GND is for the Ground connection ¹ ; PIN B (-) and PIN A (+) are for RS-485, and PIN +12V is for powering the unit
10	K-NET Connections	
11	FACTORY RESET Button	Press to revert to the default settings, including all the configured buttons

5 Using Your Room Controller

This user manual is applicable once the unit is installed and configured². The installation process is not detailed in this user manual, and includes:

- Configuration via Kramer K-Config Windows®-based configuration software and/or the IR learner
- Setting up the labels on the buttons, according to your specific requirements³
- Hardware installation
- Connecting the display

The room controller can function as:

- A master room controller that can connect to up to two auxiliary devices via K-NET
- A standalone device (which is not connected to any auxiliary device)
- An auxiliary device connected to a master room controller

¹ The ground connection is sometimes connected to the shield of the RS-485 cable (in most applications, it is not connected)

² By authorized Kramer technical personnel or by an external system integrator

³ It is recommended to place labels on the buttons prior to installing the unit, as this involves removing the face plate

[Table 9](#) summarizes the room controller functions and characteristics.

Table 9: Room Controller Functions and Characteristics

	Master	Standalone	Auxiliary
K-NET Connector(s)	Connects to up to two auxiliary devices	–	Connects to the master device
Connects to controlled machines	Yes	Yes	Yes
Requires power supply	Yes	Yes	No, receives power from the Master Controller
Requires Programming ¹	Yes	Yes	No, receives commands from the Master controller

[Figure 7](#) defines the power supply pinout for Master and standalone room controllers:

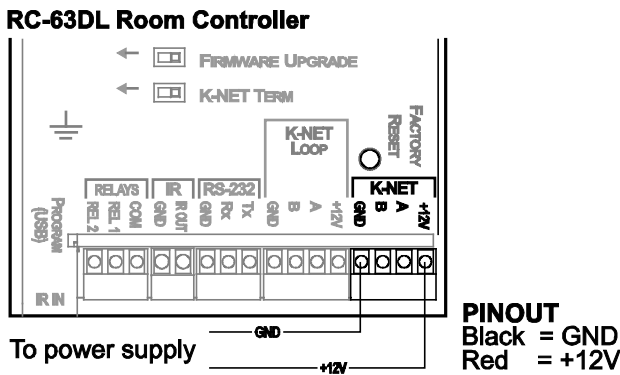

Figure 7: RC-63D Master/Standalone Power Supply Pinout

[Figure 8](#) and [Table 10](#) define² a standalone room controller. If the room controller is configured to be a Master room controller, up to two auxiliary devices can be connected via the two K-NET terminal block connectors (not shown in [Figure 8](#)).

¹ Refer to the separate K-Config online configuration software technical documentation at <http://www.kramerelectronics.com>

² Your room controller was installed and configured to suit your specific requirements. This example describes how to setup one of an unlimited number of available setups for the system

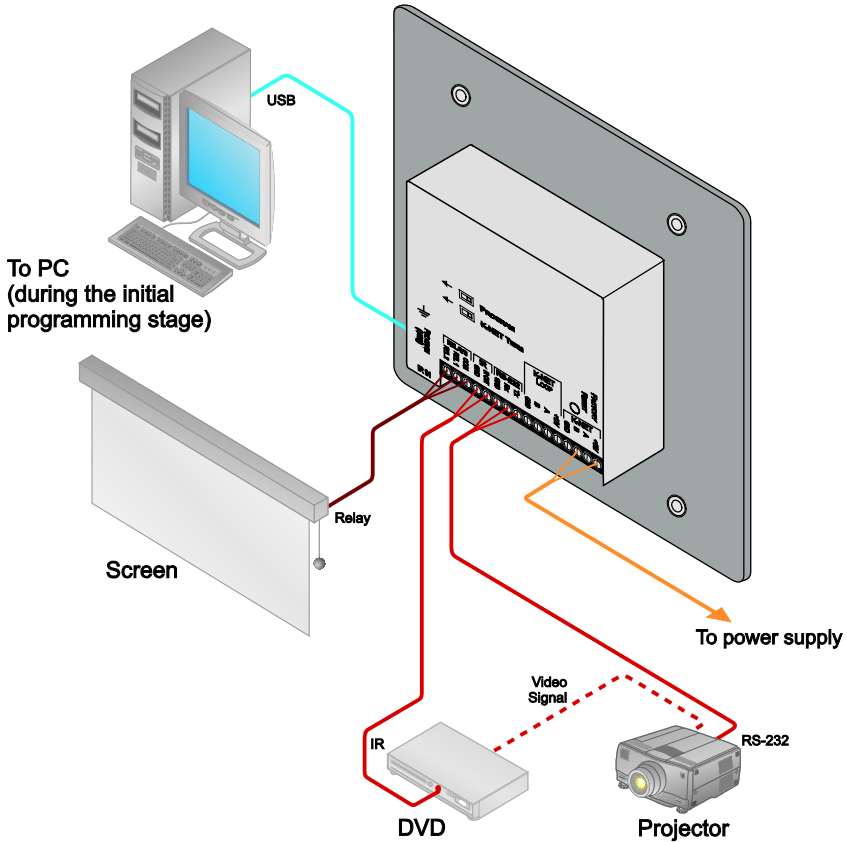

Figure 8: Example of a Typical Standalone RC-63DL Configuration

Table 10: Connection Scheme (for the example in [Figure 8](#))

This connector:	Connects to:
REL 1	The screen
REL 2	
IR OUT and GND PINs	A DVD player
RS-232 (TX, RX) Terminal Block Connector	A projector
+12V and GND	A power supply unit
A PC is connected via the USB connector for setup of the room controller	

When the room controller is used as a system controller for the *SummitView™* system via the proprietary communication channel K-NET, as illustrated in [Figure 9](#):

- It requires only a K-NET connection to the Master device (for example, the Kramer SV-551 or SV-552 *SummitView™* Processor / Switcher)
- A power supply unit is **not** required

- No programming of the room controller is needed

[Figure 9](#) shows how the room controller is used as part of the *SummitView™* system:

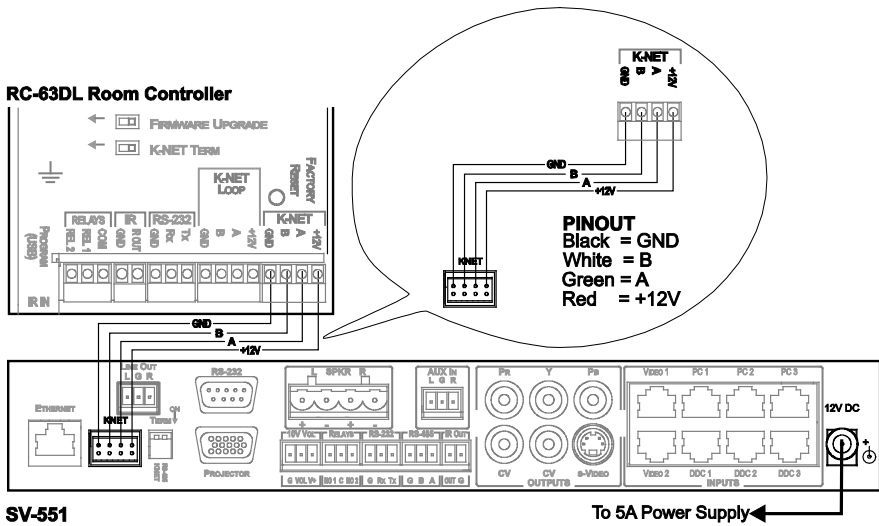

Figure 9: RC-63D connected to the SV-551 SummitView™ Processor / Switcher

5.1 Operating the Room Controller

In the following example¹ that is illustrated in [Figure 10](#), the room controller is labeled with specific functions and each button is programmed² to perform several tasks³ as defined in [Table 11](#).

Table 11: The Commands Configuration

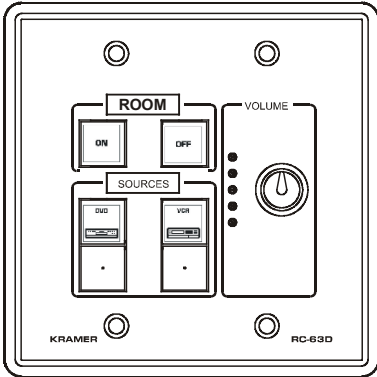

Figure 10: RC-63DL Labels Setup

The Label	The Macro Sequence
ON	<ul style="list-style-type: none"> • Power up the projector • Power up the DVD player • Roll down the projector screen • 1 minute delay [for the projector to heat up] • The projector selects the DVD input
OFF	<ul style="list-style-type: none"> • Power down the projector • Stop the DVD player • Power down the DVD player • Stop the VCR • Power down the VCR • Roll up the projector screen
DVD	<ul style="list-style-type: none"> • Stop the video player • The projector selects the DVD input • Play the DVD
VCR	<ul style="list-style-type: none"> • Stop the DVD • The projector selects the VCR input • Play the VCR
VOLUME	<ul style="list-style-type: none"> • Use the VOLUME knob to adjust the audio level

5.2 Using the Macro Buttons

Pressing any button initiates a macro sequence⁴, during which the button blinks (as programmed by the system integrator).

¹ This is only one example among numerous possibilities, each button can be configured as required. In this example, two buttons are not assigned

² By the technical installer

³ A macro sequence, including several commands per button, carried out one after the other

⁴ The macro sequence can be carried out instantly or can take a while, depending on the delay times included in the sequence

6 Customizing the Controllers' Buttons and Labels

This section describes the labels and the buttons.

6.1 Button Labels

The backlit buttons¹ are available on plastic caps. We recommend you to insert the labels on the Front Panel buttons before installing the controller, as it involves removing the face plate (see section 6.2). [Figure 11](#) illustrates the button labels for the macro buttons²:

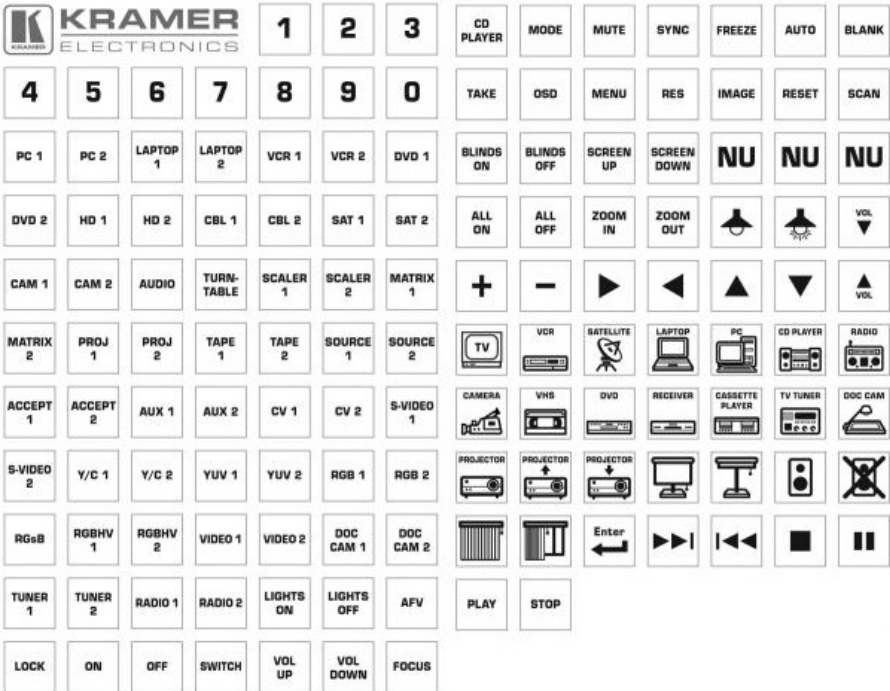

Figure 11: Sample “Button Labels” Sheet

¹ You can program the color of the button with flexible RGB values

² Installed by the system integrator only

6.2 Inserting the Button Labels

To insert a button label, do the following:

1. Unscrew the faceplate attachment screws using a screwdriver, as [Figure 12](#) illustrates:

Unscrew the faceplate attachment screws

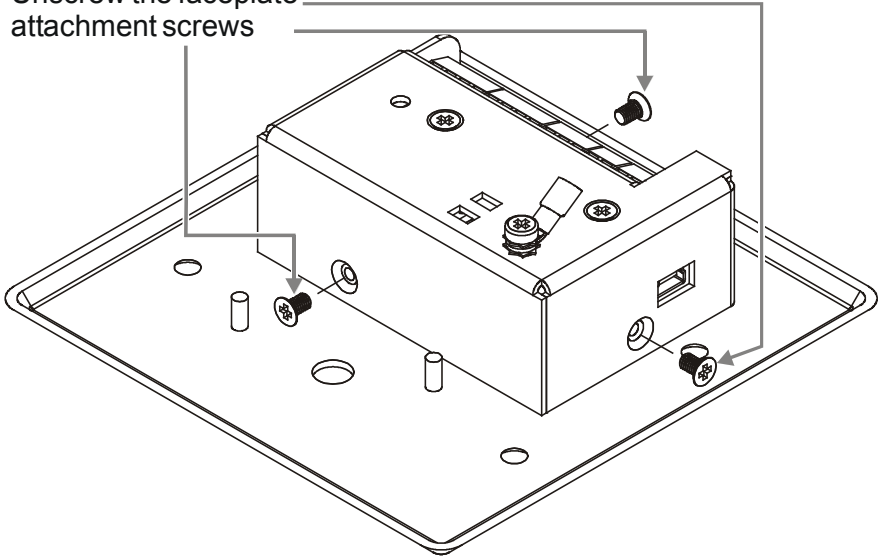

Figure 12: Unscrewing the Faceplate Attachment Screws

2. Insert the label under the button cap.
3. Place the button cap with the label onto the button base.

6.3 Replacing a Button Label

To replace a button label, do the following:

1. Unscrew the faceplate attachment screws, using a screwdriver, as [Figure 12](#) illustrates (see above).
2. Gently remove the transparent button cap with your fingers, or using adhesive tape.
3. Insert the replacement label under the button cap.
4. Replace the button cap with the label onto the button base.

6.4 Grounding the Room Controller

The grounding screw is used to earth the chassis of the unit to the building ground preventing static electricity from impacting the performance of the unit.

[Figure 13](#) and [Table 12](#) define the grounding screw components.

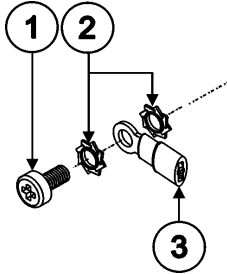

Table 12: Grounding Component Descriptions

#	Component Description
1	M3X6 screw
2	1/8" Toothed Lock Washer
3	M3 Ring Tongue Terminal

Figure 13: Grounding Connection Components

To ground the room controller:

1. Connect the Ring Tongue terminal to the building grounding point wire (it is recommended to use a green-yellow AWG#18 (0.82mm²) wire, crimped with a proper hand-tool).
2. Insert the M3x6 screw through the toothed lock washers and the tongue terminal in the order shown above.
3. Insert the M3x6 screw (with the two toothed lock washers and ring tongue terminal) into the grounding screw hole and tighten the screw.

7 Technical Specifications

[Table 13](#) defines the technical specifications:

Table 13: Technical Specifications¹ of the Room Controller Series

PORTS:	1 RS-232 on terminal block connectors; 2 K-NET on terminal block connectors; 1 USB port
OUTPUTS:	2 relays on terminal block connectors (36V AC or DC, 2A, 60VAC maximum on non-inductive load); 1 IR emitter on terminal block connectors
POWER SOURCE:	RC-62/RC-63A: 12V DC, 100mA RC-62L/RC-63D: 12V DC, 140mA RC-63DL: 12V DC, 200mA
FUSE:	500mA, FSMD 2920
ADAPTER:	<i>SummitView</i> TM kits: 12V, 5A; independent: 12V/500mA
DIMENSIONS:	RC-62 (for the USA): 6.9cm x 2.6cm x 11.4cm (2.72" x 1.02" x 4.49", W, D, H) RC-63A and RC-63D : (for the USA): 11.4cm x 2.6cm x 11.4cm (4.49" x 1.02" x 4.49", W, D, H) RC-62, RC-63A and RC-63D (for Europe): 15.2cm x 1.9cm x 8.6cm (5.98" x 0.75" x 3.39", W, D, H) RC-62/EU-80, RC-62L/EU-80, RC-63A/EU-80 and RC-63AL/EU-80 (for Europe): 15.2cm x 1.9cm x 8cm (5.98" x 0.75" x 3.39", W, D, H)
WEIGHT:	0.14kg. (0.31lbs.) approx.
ACCESSORIES:	USB cable 3' (0.91m) ² , screwdriver, Kramer K-Config software ³ , 12V DC, 0.5A Power supply ⁴
OPTIONS:	Kramer 3.5mm to IR Emitter Control Cable (C-A35/IRE-10), 15 meter and 20 meter IR emitter extension cables

¹ Specifications are subject to change without notice

² Part number C-UA/MUB-3

³ Available on our Web site at <http://www.kramerelectronics.com>

⁴ Model number AD2512C, part number 2535-000251

Technical Specifications

[Table 14](#) defines the available RC-6X series models¹:

Table 14: Available RC-6X Models

Model Name	Printed Group Labels	LCD Group Labels	US 1 Gang	US 2 Gang	Europe 2 Gang (80cm)	Europe 2 Gang (86cm)	Supplied Power Supply
RC-62	✓		✓				Worldwide
RC-62/JP	✓		✓				Japan
RC-62/EU-80	✓				✓		Worldwide
RC-62/EU-86	✓					✓	Worldwide
RC-62/GB	✓					✓	GB
RC-62L		✓	✓				Worldwide
RC-62L/JP		✓	✓				Japan
RC-62L/EU-80		✓			✓		Worldwide
RC-62L/EU-86		✓				✓	Worldwide
RC-62L/GB		✓				✓	GB
RC-63A	✓			✓			Worldwide
RC-63A/JP	✓			✓			Japan
RC-63A/EU-80	✓				✓		Worldwide
RC-63A/EU-86	✓					✓	Worldwide
RC-63A/GB	✓					✓	GB
RC-63AL		✓		✓			Worldwide
RC-63AL/JP		✓		✓			Japan
RC-63AL/EU-80		✓			✓		Worldwide
RC-63AL/EU-86		✓				✓	Worldwide
RC-63AL/GB		✓				✓	GB
RC-63D	✓			✓			Worldwide
RC-63D/JP	✓			✓			Japan
RC-63D/EU-80	✓				✓		Worldwide
RC-63D/EU-86	✓					✓	Worldwide
RC-63D/GB	✓					✓	GB
RC-63DL		✓		✓			Worldwide
RC-63DL/JP		✓		✓			Japan
RC-63DL/EU-80		✓			✓		Worldwide
RC-63D2L/EU-86		✓				✓	Worldwide
RC-63DL/GB		✓				✓	GB

¹ All models are available in a white front panel finish. For other colors, check with your local Kramer dealer

LIMITED WARRANTY

Kramer Electronics (hereafter *Kramer*) warrants this product free from defects in material and workmanship under the following terms.

HOW LONG IS THE WARRANTY

Labor and parts are warranted for seven years from the date of the first customer purchase.

WHO IS PROTECTED?

Only the first purchase customer may enforce this warranty.

WHAT IS COVERED AND WHAT IS NOT COVERED

Except as below, this warranty covers all defects in material or workmanship in this product. The following are not covered by the warranty:

1. Any product which is not distributed by Kramer, or which is not purchased from an authorized Kramer dealer. If you are uncertain as to whether a dealer is authorized, please contact Kramer at one of the agents listed in the Web site www.kramerelectronics.com.
2. Any product, on which the serial number has been defaced, modified or removed, or on which the WARRANTY VOID IF TAMPERED sticker has been torn, reattached, removed or otherwise interfered with.
3. Damage, deterioration or malfunction resulting from:
 - i) Accident, misuse, abuse, neglect, fire, water, lightning or other acts of nature
 - ii) Product modification, or failure to follow instructions supplied with the product
 - iii) Repair or attempted repair by anyone not authorized by Kramer
 - iv) Any shipment of the product (claims must be presented to the carrier)
 - v) Removal or installation of the product
 - vi) Any other cause, which does not relate to a product defect
 - vii) Cartons, equipment enclosures, cables or accessories used in conjunction with the product

WHAT WE WILL PAY FOR AND WHAT WE WILL NOT PAY FOR

We will pay labor and material expenses for covered items. We will not pay for the following:

1. Removal or installations charges.
2. Costs of initial technical adjustments (set-up), including adjustment of user controls or programming. These costs are the responsibility of the Kramer dealer from whom the product was purchased.
3. Shipping charges.

HOW YOU CAN GET WARRANTY SERVICE

1. To obtain service on your product, you must take or ship it prepaid to any authorized Kramer service center.
2. Whenever warranty service is required, the original dated invoice (or a copy) must be presented as proof of warranty coverage, and should be included in any shipment of the product. Please also include in any mailing a contact name, company, address, and a description of the problem(s).
3. For the name of the nearest Kramer authorized service center, consult your authorized dealer.

LIMITATION OF IMPLIED WARRANTIES

All implied warranties, including warranties of merchantability and fitness for a particular purpose, are limited in duration to the length of this warranty.

EXCLUSION OF DAMAGES

The liability of Kramer for any effective products is limited to the repair or replacement of the product at our option. Kramer shall not be liable for:

1. Damage to other property caused by defects in this product, damages based upon inconvenience, loss of use of the product, loss of time, commercial loss; or:
2. Any other damages, whether incidental, consequential or otherwise. Some countries may not allow limitations on how long an implied warranty lasts and/or do not allow the exclusion or limitation of incidental or consequential damages, so the above limitations and exclusions may not apply to you.

This warranty gives you specific legal rights, and you may also have other rights, which vary from place to place.

NOTE: All products returned to Kramer for service must have prior approval. This may be obtained from your dealer.

This equipment has been tested to determine compliance with the requirements of:

- EN-50081: "Electromagnetic compatibility (EMC);
generic emission standard.
Part 1: Residential, commercial and light industry"
- EN-50082: "Electromagnetic compatibility (EMC) generic immunity standard.
Part 1: Residential, commercial and light industry environment".
- CFR-47: FCC* Rules and Regulations:
Part 15: "Radio frequency devices
Subpart B Unintentional radiators"

CAUTION!

- Servicing the machines can only be done by an authorized Kramer technician. Any user who makes changes or modifications to the unit without the expressed approval of the manufacturer will void user authority to operate the equipment.
- Use the supplied DC power supply to feed power to the machine.
- Please use recommended interconnection cables to connect the machine to other components.

* FCC and CE approved using STP cable (for twisted pair products)





For the latest information on our products and a list of Kramer distributors, visit our Web site: www.kramerelectronics.com, where updates to this user manual may be found. We welcome your questions, comments and feedback.



Caution

Safety Warning:

Disconnect the unit from the power supply before opening/servicing.



Kramer Electronics, Ltd.

Web site: www.kramerelectronics.com

E-mail: info@kramerel.com

P/N: 2900-000473 REV 3