

DA22DIG

Quick Reference Guide

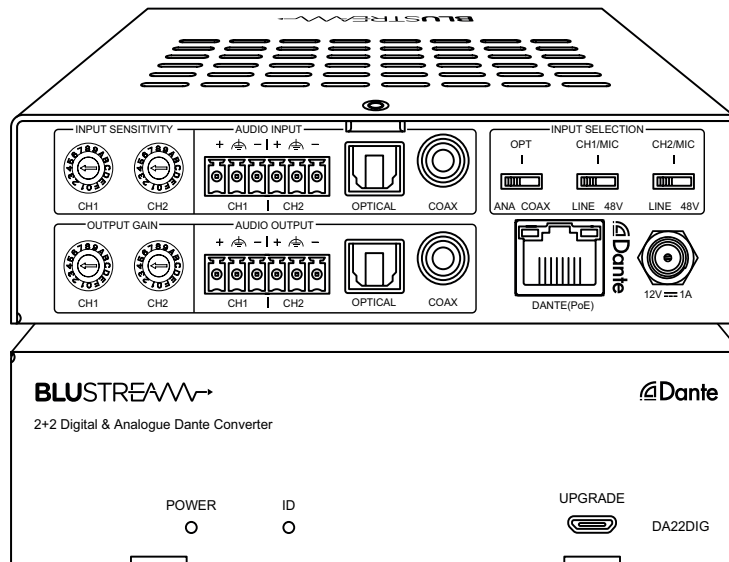

Introduction

Our DA22DIG has been designed to both encode 2ch analogue or digital audio to a Dante® digital signal, and decode a Dante® digital signal to 2ch analogue and digital audio. The DA22DIG features both analogue audio and digital audio connections, selectable via dip-switch and is a plug & play device that is powered using PoE (Power over Ethernet), or via 12V power supply. The DA22DIG also features support for microphones including 48V phantom power, as well as support for AES67 RTP audio transport.

FEATURES:

- Encodes 2ch analogue audio or digital audio to Dante® digital signal
- Decodes a Dante® digital signal to 2ch analogue audio and digital audio
- Selectable digital audio between optical toslink and coaxial RCA inputs
- Configurable MIC audio input with 48V phantom power
- Independent sensitivity control for input channels, and gain control for output channels
- Supports: 44.1, 48 & 96kHz sample rates @ 24 Bit
- Configurable Dante® device latency (supports 1, 2 or 5ms configurable using Dante® Controller)
- Supports AES67 RTP audio transport
- Features Class 3 IEEE 802.3af PoE for powering of product from any PoE switch
- Supports power via 12V DC adapter (supplied) for when network switch does not support PoE

Front Panel

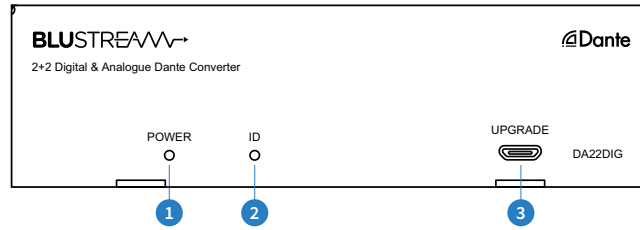

Connections:

- 1 Power Status Indicator - Illuminates when the devices is powered on
- 2 ID LED Indicator - Illuminates or flashes when this device is identified through Dante® Configurator
- 3 Micro USB Upgrade Port - Used for firmware updates

Rear Panel

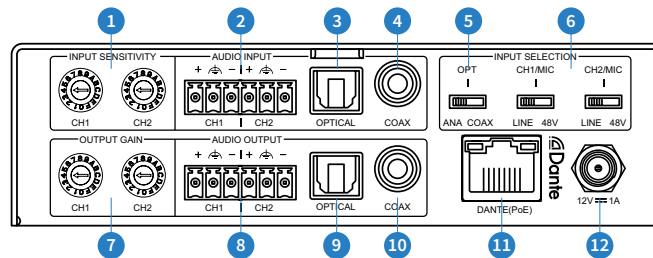

Connections:

- 1 Input Sensitivity Dial - Rotate to adjust the input sensitivity of the analogue audio input connections
- 2 Analogue Audio Input - 6-pin Phoenix connector for balanced or unbalanced analogue audio input
- 3 Optical Audio Input - Toslink connector connects to digital audio source device (2ch PCM only)
- 4 Coaxial Audio Input - Coaxial connector connects to digital audio source device (2ch PCM only)
- 5 Input Selection Switch - Select Dante® audio input between Analogue, Optical or Coaxial inputs
- 6 Analogue Input Type Switch - Select between Line input, Microphone input or 48V phantom power input
- 7 Output Gain Dial - Rotate to adjust the output gain of the analogue audio output connections
- 8 Analogue Audio Output - 6-pin Phoenix connector for balanced or unbalanced analogue audio output
- 9 Optical Audio Output - Toslink connector to audio amplification or distribution device (2ch PCM only)
- 10 Coaxial Audio Output - Coaxial connector to audio amplification or distribution device (2ch PCM only)
- 11 Dante® Network Connection (PoE) - RJ45 connection to connect to network switch
- 12 Power Port - Use included 12V/1A DC adaptor when PoE is not available to power device

Input Sensitivity / Output Gain

The DA22DIG features rotary dials that allow you to adjust both the input sensitivity and output gain of each of the analogue channels.

Simply rotate the dial and align the arrow to one of the 16 hexadecimal switch positions. The input sensitivity or output gain level will correspond to the position as per the table adjacent (also printed on the underside of the device itself).

Please note: Due to the low input signal from microphones, when input selection is set to MIC, switch positions 0-8 are fixed to 0dB and it is recommended to use Input Sensitivity DIP switches from 8 to F to avoid clipping of the input signal.

DIP	INPUT SENSITIVITY	LINE INPUT VRMS	OUTPUT GAIN	OUTPUT VRMS
0	+24dBu (0dBu MIC)	12.28 (0.775 MIC)	+20dBu	7.746
1	+21dBu (0dBu MIC)	8.691 (0.775 MIC)	+18dBu	6.153
2	+18dBu (0dBu MIC)	6.153 (0.775 MIC)	+15dBu	4.356
3	+15dBu (0dBu MIC)	4.356 (0.775 MIC)	+12dBu	3.084
4	+12dBu (0dBu MIC)	3.084 (0.775 MIC)	+9dBu	2.183
5	+9dBu (0dBu MIC)	2.183 (0.775 MIC)	+6dBu	1.546
6	+6dBu (0dBu MIC)	1.546 (0.775 MIC)	+4dBu	1.228
7	+4dBu (0dBu MIC)	1.228 (0.775 MIC)	0dBu	0.775
8	0dBu	0.775	0dBV	1
9	0dBV	1	-3dBV	0.708
A	-3dBV	0.708	-6dBV	0.501
B	-6dBV	0.501	-10dBV	0.316
C	-10dBV	0.316	-14dBV	0.2
D	-14dBV	0.2	-20dBV	0.1
E	-20dBV	0.1	-24dBV	0.0631
F	-28dBV	0.04	-28dBV	0.04

Dante® Controller

Dante® Controller software is required in order to set up and configure the DA22DIG as well as control the Dante® network. Audinate provide extensive training videos and documentation on their website. This can be found here: <http://www.audinate.com/products/software/dante-controller>

Upon connecting your DA22DIG to a compatible network, the Dante® Controller software should automatically discover the device. The DA22DIG will appear in the Dante® Controller with a name prefixed with “DA22DIG”. On the “Routing” screen you can create audio routing between Dante® transmitters and receivers in the system.

Please ensure your PC is on the same network as your Dante® devices. Dante® is not able to transmit over WiFi, and it is recommended to hardwire into the Dante® network. Having multiple network devices enabled can also confuse the Dante® Controller software so it is recommended to disable WiFi during configuration.

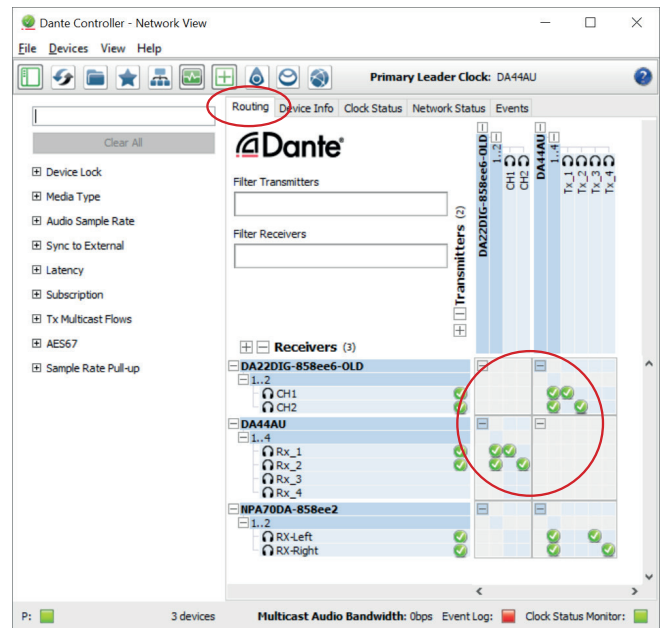

Advanced Dante® Settings

By default the DA22DIG is shipped with its network settings set to obtain an IP address automatically. This means that if a DHCP server is present on your network, it will provide the DA22DIG with an IP address. If no DHCP server is present then the DA22DIG will receive a default IP address in the 169.254.xxx.xxx range.

To change the IP address of the DA22DIG, you must enter the “Network Config” menu in the “Device Info” screen of the Dante® Controller software.

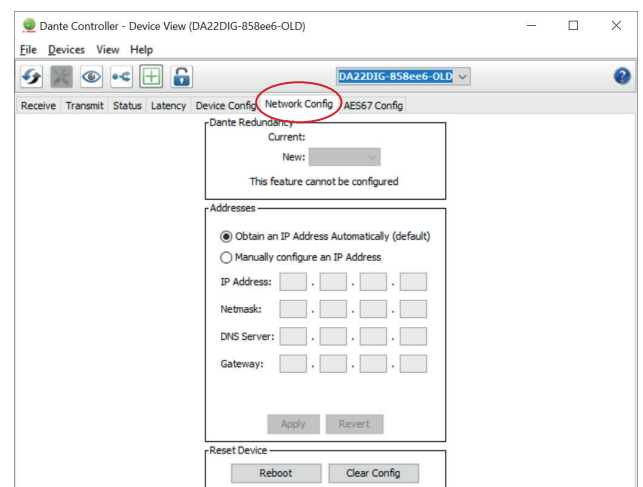

It is also possible to change the settings of the DA22DIG under the “Device Info” screen in the Dante® Controller software. To do so, select the “Device Config” menu.

The sample rate of the DA22DIG can be adjusted here. **Please note:** Dante® products can only transmit or receive audio from other Dante® products that are set up with the same sample rate. A mismatch in sample rate may stop audio from transmitting.

Under the “Device Config” screen we can also adjust the latency of the DA22DIG from 1, 2 or 5 milliseconds.

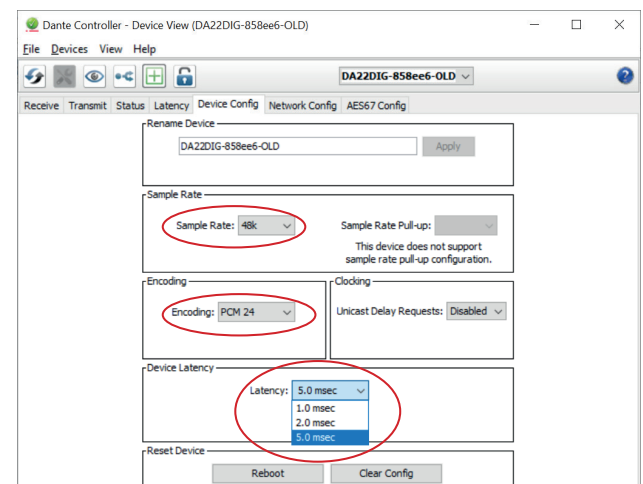

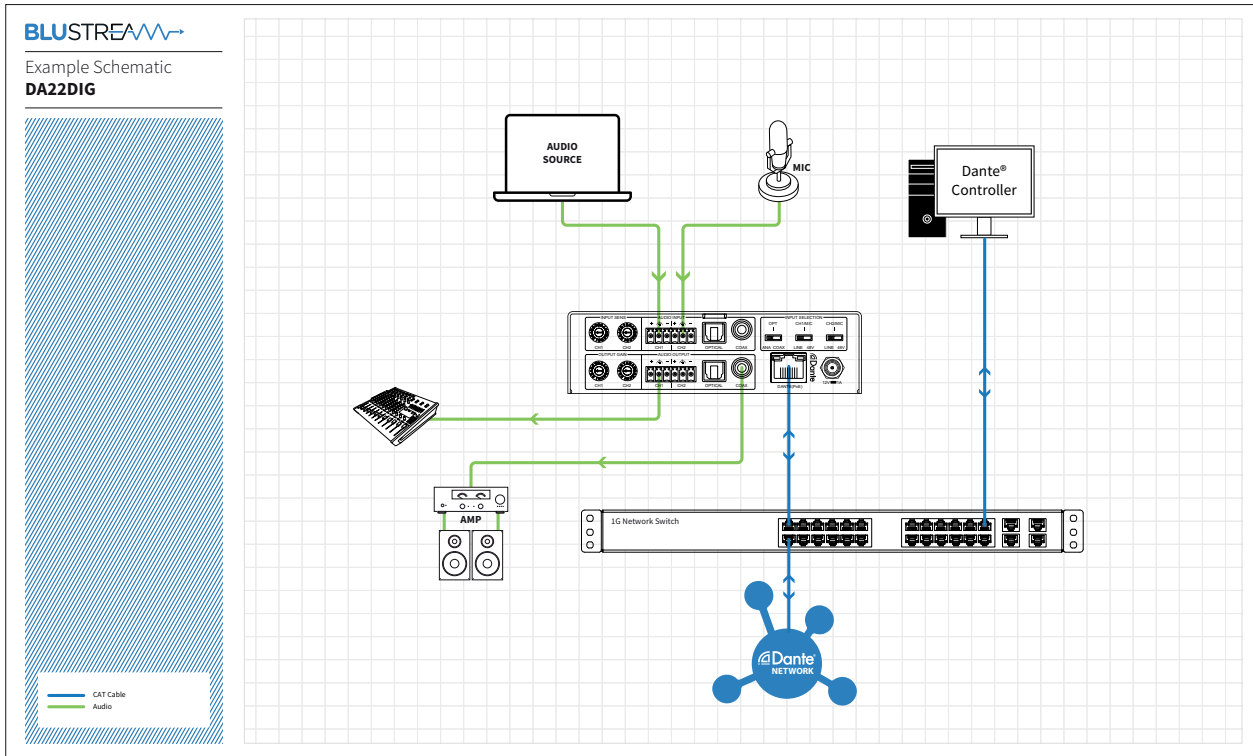

Specifications

Audio Input Connectors: 2 x Analogue Balanced/Unbalanced, 6-Pin Phoenix connector, 1 x Optical (S/PDIF), 1 x Coaxial (RCA)

Audio Output Connectors: 2 x Analogue Balanced/Unbalanced, 6-pin Phoenix connector, 1 x Optical (S/PDIF), 1 x Coaxial (RCA)

Network Connectors: 1 x PoE Dante® Ethernet Connection (RJ45)

Configuration Switches: 4 x 16 Level Rotary Dials, 3 x 3-Position Switch

Casing Dimensions (L x W x H): 135mm x 80mm x 38mm

Shipping Weight: 0.5kg

Operating Temperature: 32°F to 104°F (0°C to 40°C)

Storage Temperature: - 4°F to 140°F (- 20°C to 60°C)

Power Supply: Class 3 IEEE 802.3af POE PD or 12V/1A DC, Screw Type Connector

Package Contents

- 1 x DA22DIG
- 1 x Mounting Kit
- 1 x 12V / 1A DC Power Supply
- 1 x Quick Reference Guide

Acknowledgements

Dante® is a registered trademark of Audinate Pty Ltd.

Certifications

FCC NOTICE

This equipment has been tested and found to comply with the limits for a Class B digital device, pursuant to part 15 of the FCC Rules. These limits are designed to provide reasonable protection against harmful interference in a residential installation. This equipment generates, uses, and can radiate radio frequency energy and, if not installed and used in accordance with the instructions, may cause harmful interference to radio communications. However, there is no guarantee that interference will not occur in a particular installation. If this equipment does cause harmful interference to radio or television reception, which can be determined by turning the equipment off and on, the user is encouraged to try to correct the interference by one or more of the following measures:

- Reorient or relocate the receiving antenna.
- Increase the separation between the equipment and receiver.
- Connect the equipment into an outlet on a circuit different from that to which the receiver is connected.
- Consult the dealer or an experienced radio/TV technician for help.

CAUTION - changes or modifications not expressly approved by the party responsible for compliance could void the user's authority to operate the equipment.

CANADA, INDUSTRY CANADA (IC) NOTICES

This Class B digital apparatus complies with Canadian ICES-003. Operation is subject to the following two conditions: (1) this device may not cause interference, and (2) this device must accept any interference, including interference that may cause undesired operation of the device.

CORRECT DISPOSAL OF THIS PRODUCT

This marking indicates that this product should not be disposed with other household wastes. To prevent possible harm to the environment or human health from uncontrolled waste disposal, recycle it responsibly to promote the sustainable reuse of material resources. To return your used device, please use the return and collection systems or contact the retailer where the product was purchased. They can take this product for environmentally safe recycling.